

All-Optical Sampling Utilising Two-Photon Absorption in a Semiconductor Micro-Cavity

P.J.Maguire, L.P.Barry, T.Krug, M.Lynch, A.L.Bradley, J.F.Donegan and H.Folliot

A highly-efficient optical sampling system based on Two-Photon Absorption in a semiconductor micro-cavity is presented. The sensitivity of the sampling system is calculated to be 0.1mW^2 with a temporal resolution of 2ps.

Introduction: In order to successfully operate at aggregate data rates in excess of 100Gbit/s, Optical Time Division Multiplexed (OTDM) networks will require a sensitive and ultrafast technique for precise optical signal monitoring [1]. The standard way of characterising high-speed optical signals utilises a fast photodetector in conjunction with a high-speed oscilloscope, which is limited to maximum data rates of around 40Gbit/s. To accurately monitor high-speed optical data signals at data rates upto and beyond 100 Gbit/s it is necessary to make use of non-linear effects that are present in optical fibres and semiconductors, as these occur on timescales in the order of a few femtoseconds. One such example is Two-Photon Absorption (TPA). As TPA is an instantaneous optical nonlinearity, it may be used for all-optical high-speed sampling in photonic systems [2]. In an all-optical sampling scheme employing TPA, the temporal resolution is limited only by the duration and jitter of the sampling pulses used. The main difficulty with using TPA for high-speed optical sampling is its inherent inefficiency, which means that such systems would either requires high optical intensities or very long detectors, making them unsuitable for practical telecommunications applications. One possible way to overcome this efficiency problem is to employ a semiconductor micro-cavity [3], which should significantly enhance the TPA response of the device, and enable the implementation of a practical

sampling elements for high-speed optical systems. In this paper, a highly sensitive and efficient method for optical sampling utilising TPA in a semiconductor micro-cavity is demonstrated. By incorporating the micro-cavity in an optical sampling set-up, we have obtained a sensitivity of 0.1mW^2 , with a temporal resolution of 2ps. The sensitivity achieved is in excess of an order of magnitude improvement on the sensitivity when compared to other TPA sampling schemes [4].

Principle of TPA Sampling Operation: The phenomenon of TPA is a nonlinear optical-to-electrical conversion process where two photons are absorbed in the generation of a single electron-hole pair [5]. It occurs when a photon of energy E_{ph} is incident on the active area of a semiconductor device with a bandgap exceeding E_{ph} but less than $2E_{\text{ph}}$. The generated photocurrent is proportional to the square of the intensity, and it is this nonlinear response that enables the use of TPA for optical sampling.

As already mentioned, a Fabry-Perot micro-cavity can be to greatly enhance the optical intensity by increasing the interaction length in the device [5]. The device, which is specifically fabricated for TPA at 1550nm in our work, consists of a GaAs/AlAs PIN micro-cavity photodetector grown on a GaAs substrate. The front p-doped mirror consists of 9 pairs while the back n-doped mirror consists of 18 pairs designed for reflectivity at 1550nm. The device studied was a $100\mu\text{m}$ diameter vertical structure [3]. Fig. 1 shows the TPA photocurrent as a function of wavelength around the micro-cavity resonance of one of the samples grown when an optical peak power level of 100mW is incident on the sample. It clearly shows how the cavity response is dependent on the incident wavelength, with a cavity resonance of 1554nm and a measured cavity linewidth of 5nm. A photocurrent measurement as a function

of the incident optical power close to the cavity resonance was also carried out on the same sample. The results from this showed that there was a square dependence of the photocurrent as a function of the incident optical intensity over a dynamic range of almost 40dB, evidencing the TPA process.

In order to use TPA for optical sampling, the duration of the optical sampling pulse $I_{\text{sam}}(t-\tau)$ used must be significantly shorter than the optical signal pulses $I_{\text{sig}}(t)$ under test. The signal and sampling pulses are then incident on the micro-cavity device and the electrical signal $i(\tau)$ generated by the TPA process in the device is measured as a function of the sampling delay τ . This results in an intensity cross-correlation measurement between I_{sam} and I_{sig} . For the practical implementation of a TPA sampling system, it is convenient to use a sampling pulse with a peak intensity much larger than the signal intensity. In this case, for a sufficiently short sampling pulse, the measured signal represents the signal pulse waveform on a constant background [4].

Experimental Set-up: Fig. 2 shows the experimental setup for the optical sampling system. A 10GHz tunable pulse source was used for the initial characterization of the micro-cavity devices and for the sampling. The pulse duration was approximately 1.8ps, with a timing jitter $< 500\text{fs}$, and the operating wavelength was set to 1554nm, to coincide with the wavelength resonance of the cavity. The 10GHz pulse train was first amplified using a low noise Erbium Doped Fibre Amplifier (EDFA) and then passed through a 1x4 optical coupler. The pulse train from O/P1 was used as the signal pulse under test for the experiment involving the sampling of a single optical pulse, while O/P2 and O/P3 were used for the creation of the quasi-160GHz signal. O/P4 was used as the sampling pulse for the system. When not in use, O/P1 was connected to an optical isolator to prevent any backward reflections. To synthesis the

quasi-160GHz signal, the 10GHz signal emerging from O/P2 passed through an Optical Delay Line (ODL) which delayed the pulse train by ~ 7 ps with respect to the signal from O/P3. To compensate for the insertion loss introduced by the ODL, O/P3 was attenuated by 1dB. Both pulse trains (O/P2 and O/P3) were then recombined at the coupler to form the quasi-160GHz signal. An optical chopper was placed in the sampling arm (O/P4) to allow a lock-in amplifier to measure the TPA photocurrent after the micro-cavity. The sampling pulse then passes through an ODL, which is used to introduce the sampling delay τ . The signal and sampling pulse trains then pass through in-line power meters/attenuators and polarisation controllers before being recombined at a coupler. The power meters allow for easy measurement and attenuation of both signal and sampling pulses, allowing the sensitivity of the system to be monitored. Finally the sampling and signal pulse are incident on the micro-cavity with the photocurrent generated by the device fed into the lock-in amplifier. The electrical output was then recorded as a function of the sampling delay τ . The quality of the TPA sampling technique is independently verified by comparing the resulting output of the TPA sampling with the corresponding results from an SHG-FROG (Second Harmonic Generation – Frequency Resolved Optical Gating) [6] measurement of the same pulse.

Experimental Results: Fig. 3 (a) shows the experimental result of TPA sampling versus the SHG-FROG measurement for a single pulse. From the TPA sampling, the optical pulse duration was calculated to be ~ 2.4 ps whereas from the SHG-FROG measurement the pulse width was ~ 1.8 ps. The deviation between the two can be accounted for by the temporal resolution of the sampling set-up (which is determined by the duration and jitter of the sampling pulse [4] and the cavity lifetime). The peak

power of the signal and sampling pulses were 2.7mW and 8.6mW respectively. Fig. 3 (b) compares the TPA sampling against the SHG-FROG measurement of the quasi-160GHz signal. As already stated, the deviation between the two can be accounted for by the cavity lifetime and the temporal resolution of the system. As the pulse separation is approximately 7ps, this highlights that sampling of a 160Gbit/s signal should be possible. The overall system sensitivity, which is the product of the peak power of the signal pulse and the average power of the sampling pulse when the optical power levels are reduced to levels such that the signal can just be correctly detected at minimum power levels was calculated to be 0.1mW^2 , corresponding to a signal peak power of 1.6mW and a sampling peak power of 4mW.

Conclusion: We have shown that by using a micro-cavity device, we are able to enhance the TPA efficiency to a level that can be used to successfully sample a 160Gbit/s optical signal with a sensitivity calculated to be 0.1mW^2 (corresponds to an signal pulse peak power of 1mW) with the temporal response being $\sim 2\text{ps}$. These results represent the most sensitive ultra-fast TPA optical sampling system reported. This level of sensitivity was also achieved without the need for any post-amplification of the electrical TPA photocurrent. It is anticipated that with the addition of a low noise amplifier after the detector, the sensitivity could be further enhanced. Also by reducing the sampling pulse duration, the temporal response of the sampling system could be further improved. It is anticipated that this technique could have applications for high-speed signal monitoring in future OTDM/WDM communication systems.

References:

- [1] S.Kawanishi, "Ultrahigh-Speed Optical Time-Division-Multiplexed Transmission Technology Based on Optical Signal Processing", *IEEE Journal of Quantum Electronics*, **34**, pp2064-2079, 1998
- [2] K.Kikuchi, "Optical sampling system at 1.5 μ m using two photon absorption in Si avalanche photodiode", *Electronic Letters*, **34**, pp1354-1355, 1998
- [3] T.Krug, M.Lynch, A.L.Bradley, J.F.Donegan, L.P.Barry, H.Folliot, J.S.Roberts and G.Hill, "High-Sensitivity Two-Photon Absorption Microcavity Autocorrelator", *IEEE Photonics Technology Letters*, **16**, pp1543-1544, 2004
- [4] B.C.Thomsen, L.P.Barry, J.M.Dudley and J.D.Harvey, "Ultra Sensitive All-Optical Sampling Scheme for use in high capacity telecommunication systems at 1.5 μ m", *Electronic Letters*, **35**, pp1483-1484, 1999
- [5] H.Folliot, M.Lynch, A.L.Bradley, T.Krug, L.A.Dunbar, J.Hegarty, J.F.Donegan and L.P.Barry, "Two-photon-induced photoconductivity enhancement in semiconductor microcavities: A theoretical investigation", *Journal of the Optical Society of America B*, **19**, pp2396-2402, 2002
- [6] R.Trebino, K.W.DeLong, D.N.Fittinghoff, J.N.Sweetser, M.A.Krumbugel and B.A.Richman, "Measuring ultrashort laser pulses in the time-frequency domain using frequency-resolved optical gating", *Review of Scientific Instruments*, **68**, pp3277-3295, 1996

Authors' affiliations:

P.J.Maguire and L.P.Barry (*Research Institute for Networks and Communications Engineering, Dublin City University, Dublin 9, IRELAND*)

Email: maguirep@eeng.dcu.ie

T.Krug, M.Lynch, A.L.Bradley and J.F.Donegan (*Semiconductor Optronics Group, Physics Department, Trinity College, Dublin 2, IRELAND*)

H.Folliot (*Laboratoire de Physique des Solides, INSA, Rennes, FRANCE*)

Figure Captions:

Fig. 1 TPA photocurrent as a function of the incident optical wavelength across micro-cavity resonance.

Fig .2 Experimental set-up for the TPA sampling.

Fig. 3 (a) TPA sampling versus FROG measurement of a single pulse

(b) TPA sampling versus FROG measurement of a quasi-160GHz signal

● Sampled Pulse

— SHG-FROG Measurement

Figure 1

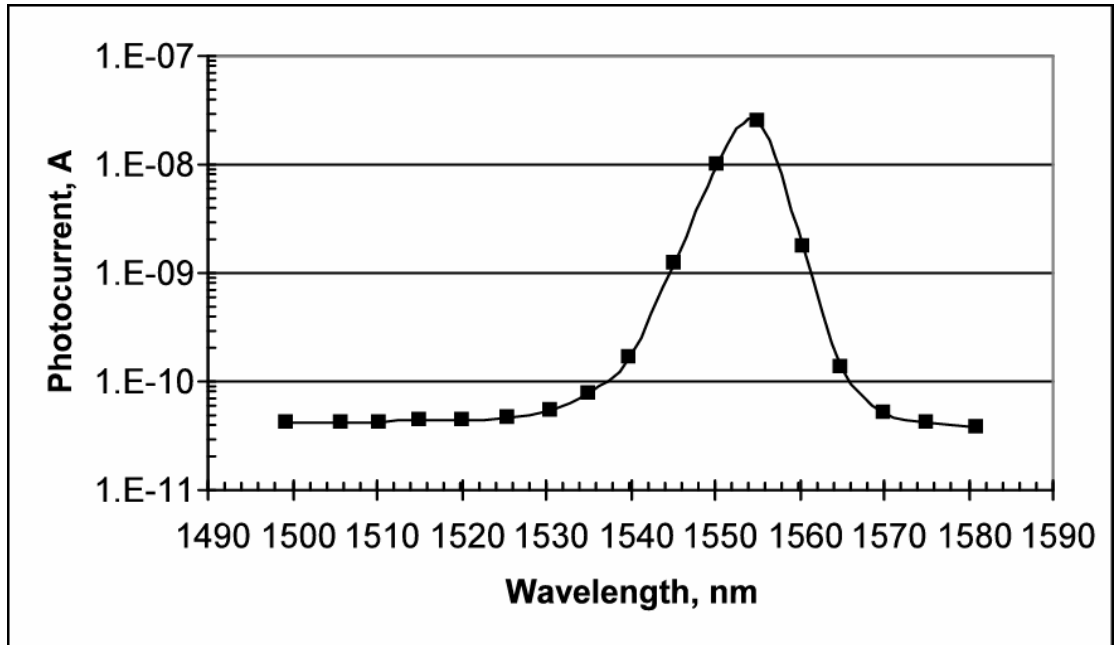

Figure 2

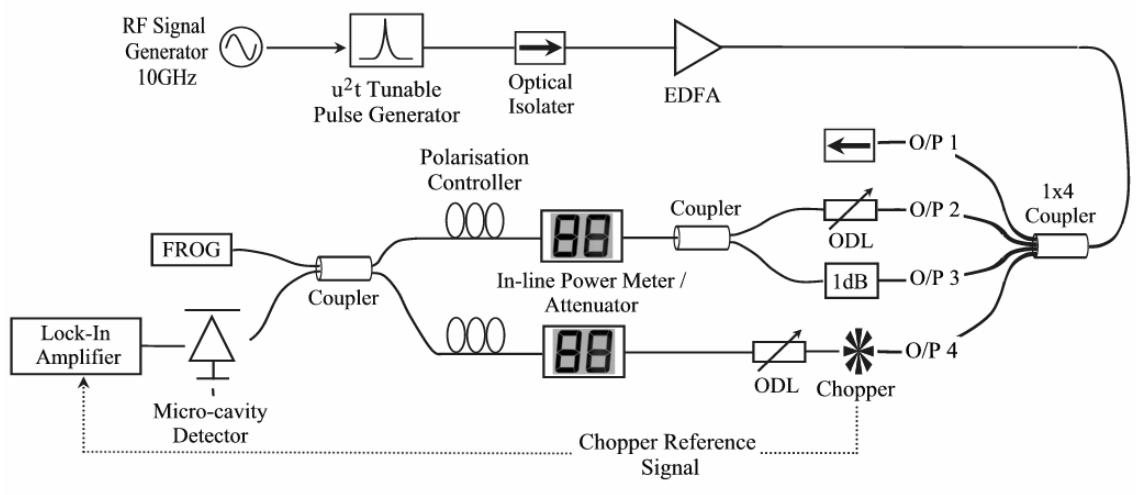

Figure 3

