

Characterization of Frequency Drift of Sampled-Grating DBR Laser Module Under Direct Modulation

Prince M. Anandarajah, *Member, IEEE*, Robert Maher, *Student Member, IEEE*, Liam P. Barry, *Member, IEEE*, Aleksandra Kaszubowska-Anandarajah, *Member, IEEE*, E. Connolly, Tom Farrell, and David McDonald

Abstract—The authors demonstrate the drift in frequency of a static sampled-grating distributed Bragg reflector (SG DBR) laser module when it is subjected to direct modulation. The magnitude of drift and its settling time is characterized as a function of the index of modulation. Results show that when the directly modulated SG DBR is optically filtered, as in a dense wavelength-division-multiplexed system, a power penalty of 6.7 dB is incurred in comparison to the unfiltered case.

Index Terms—Dense wavelength-division multiplexing (DWDM), direct intensity modulation, laser stability, optical fiber communications, tunable lasers (TLs).

I. INTRODUCTION

WAVELENGTH tunable lasers (TLs) are rapidly becoming a mainstream component in dense wavelength-division-multiplexed (DWDM) systems, packet switched schemes, and access networks. They are being introduced as alternatives to fixed wavelength sources to provide a greater degree of flexibility [1] and to reduce large inventory [2]. The sampled-grating distributed Bragg reflector (SG DBR) TL proves to be an ideal candidate, due to its large tuning range (40 nm), high output power (10 dBm), high sidemode suppression ratio (SMSR > 30 dB), and simplicity of integration [3].

Thus far, external modulation has been the most popular modulation technique used with TLs. However, this method, despite its obvious advantages, introduces loss to the transmitted power due to high insertion and coupling losses of the modulator (LiNbO₃ or semiconductor). Addressing these deficiencies would lead to increased cost and complexity of the transmitter. Alternatively, direct modulation is one of the most simple and efficient ways to modulate the lightwave signal. Moreover, direct modulation has inherently a more linear response than most optical modulators [3]. Hence, it is rational to investigate the performance of a directly modulated SG DBR laser in order to

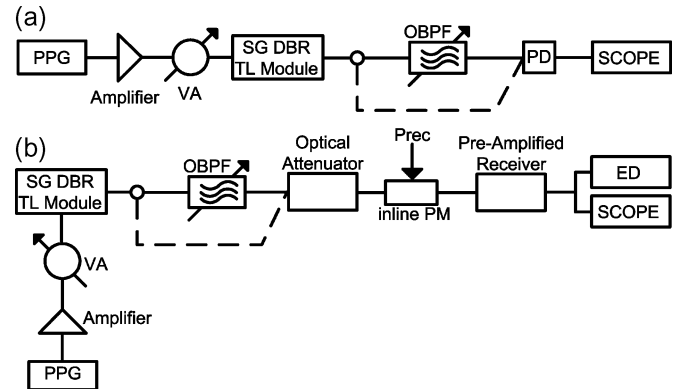

Fig. 1. Experimental setup.

verify its usefulness especially for short reach applications such as in WDM-based access networks.

Previous work in this area, involving the direct modulation of TLs, has mainly focused on bandwidth characterization and transmission experiments [4], [5]. Recently, Liu *et al.* reported a 0.2-nm wavelength drift of an uncooled DBR laser, that was directly modulated at 3.125 Gb/s, over a temperature range of 20 °C–90 °C [6]. However, in this letter, we characterize the frequency drift associated with a directly modulated SG DBR laser incorporating a wavelength locker (TL module). Focus is placed on investigating the magnitude and settling time of this drift as a function of the direct intensity modulation index. In addition, we also demonstrate how the frequency drift has a detrimental effect on DWDM system performance when the modulated channel is passed through a narrow optical bandpass filter (OBPF) centered at the target emission frequency. To the best of our knowledge, this is the first time the impact of the drift due to direct modulation of such a TL module in a WDM system has been examined.

II. EXPERIMENTAL SETUP

Initially, we measure the frequency drift using a two-stage experimental setup as shown in Fig. 1(a). The TL used was a temperature-controlled fast wavelength-switched transmitter, tunable over the entire C-band. It also featured a custom-made high-speed RF input, attached to the gain section of the device, to enable direct modulation. The modulation bandwidth of the device under test was characterized to be about 1 GHz. This limitation is mainly due to the unoptimized electronic circuitry

Manuscript received August 10, 2007; revised October 8, 2007. This work was supported by Science Foundation Ireland (Investigator Program).

P. M. Anandarajah, R. Maher, L. P. Barry, A. Kaszubowska-Anandarajah, and E. Connolly are with the Research Institute for Networks and Communications Engineering, Dublin City University, Glasnevin, Dublin 9, Ireland (e-mail: prince.anandarajah@dcu.ie; anandara@eeng.dcu.ie; robert.maher@eeng.dcu.ie; barryl@eeng.dcu.ie; kaszubow@eeng.dcu.ie).

T. Farrell and D. McDonald are with Intune Networks, Beckett Way, Parkwest, Dublin 12, Ireland (e-mail: tom.farrell@intunenetworks.eu; david.mcdonald@intunenetworks.com).

Digital Object Identifier 10.1109/LPT.2007.912478

attached to the gain section of the device that allows direct modulation.

The TL is operated in static mode and the emission wavelength was set to channel 38 (1550.4 nm–193.35 THz). The TL is then directly modulated at 1 Gb/s with the aid of a pulse pattern generator (PPG). A modulator driver amplifier in conjunction with a variable attenuator, placed between the PPG and the TL, were used to vary the direct intensity modulation index through values 0.1–0.6 (corresponding to peak-to-peak voltages of 0.5–3 V, respectively). Initially a power reference measurement, denoted by the dotted line in Fig. 1(a), is taken where the output of the directly modulated TL is detected by a photodiode in conjunction with an oscilloscope. Subsequently, the modulated signal is passed through an OBPF with a 3-dB bandwidth of 26 GHz, detuned by 0.1 nm to create a sloped frequency discriminator [7]. The frequency discriminator essentially assists in characterizing the offset in frequency of the TL, from the set International Telecommunication Union (ITU) reference frequency. By detuning the filter, the set ITU frequency is made to lie on a portion with a higher rejection (lower power) of the filter transfer characteristic. On the application of the modulating signal, the frequency of the TL is offset towards a lower rejection side of the filter transmission resulting in a higher amount of optical power being detected. Subsequently, as the in-built wavelength locker drags the output signal back to its target frequency, a smaller output power from the filter is recorded. The power reference measurement is then subtracted from the filtered signal, which mitigates the intensity variation due to direct modulation thereby ensuring that any variation in the received power is solely due to the frequency drift of the TL. These variations in power can be translated to corresponding frequency deviations by using the optical filter response.

Subsequently, a qualitative characterization of the frequency drift, caused by direct modulation of such a TL employed in a DWDM system, is determined by performing bit-error-rate (BER) measurements. The experimental setup with and without (dotted line) the OBPF is illustrated in Fig. 1(b). Here again, the TL is set to emit at channel 38 (193.35 THz) and then modulated with a 1-Gb/s nonreturn-to-zero pseudorandom bit sequence with a pattern length of $2^7 - 1$. The modulation index is set to be 0.2. An optical attenuator incorporated with an in-line power meter (P_{rec}) enables the monitoring of the varied received power falling on the preamplified receiver. The BER is then measured with the aid of an error detector under three different scenarios namely: no filter (dotted line), with the 26-GHz filter centered at the specified ITU frequency (193.35 THz), and with the 26-GHz filter centered at the average shifted frequency upon direct modulation (193.343 THz). Eye diagrams are also recorded with the aid of a 50-GHz sampling oscilloscope for each of the mentioned permutations.

III. RESULTS AND DISCUSSION

Fig. 2 illustrates the frequency drift and the settling time of the directly modulated TL when the modulation index is set to 0.2. The negative frequency values on the y-axis indicate a drift from the set ITU frequency towards lower frequencies when the TL is subjected to direct modulation. We define the frequency

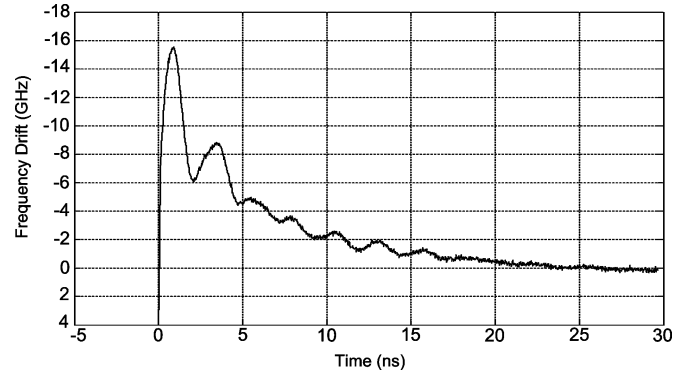

Fig. 2. Single channel frequency drift caused by direct modulation with the index set to 0.2.

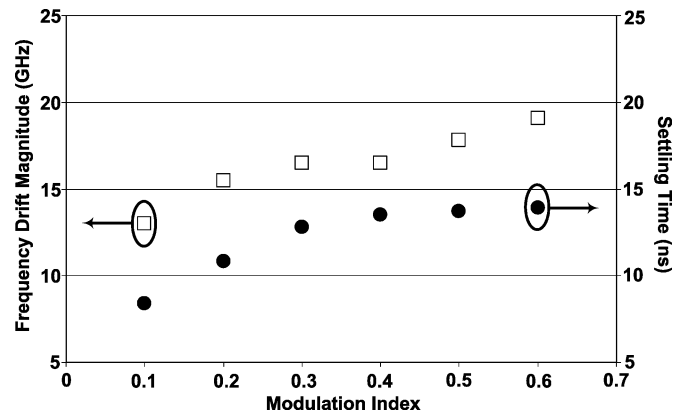

Fig. 3. Magnitude and settling time of frequency drift as a function of applied intensity modulation index.

drift as the maximum offset caused by the direct modulation during the presence of a logical one. The settling time is defined as the time the wavelength locker takes to counter-act this offset in frequency caused by direct intensity modulation and get within 2.5 GHz of the target ITU frequency. From Fig. 2 we can see that the frequency offset is measured to be about 15 GHz when the index is set to 0.2. It is important to note that the settling time mainly depends on the pattern length used (number of consecutive ones). In order to measure the longest settling time (worst-case scenario), a programmed sequence consisting of 30 ones followed by 30 zeros is used. As can be seen in Fig. 2, the settling time is measured to be approximately 11 ns. If an alternating data pattern is used to directly modulate the TL, the presence of a logical one would result in an offset based on the index of modulation while a logical zero would bring the signal back to its initially set (target) frequency.

Fig. 3 shows the variation of the magnitude and settling times of the drift as a function of the modulation index. This figure clearly shows that the magnitude of frequency drift increases with increasing modulation indexes. The maximum frequency offset is measured to be about 19 GHz when the index is set to 0.6. As expected, this frequency offset gets progressively smaller with smaller indexes of modulation. With the index set to 0.1, the offset is measured to be about 13 GHz. The frequency drift can be attributed to refractive index changes in the gain section (due to modulation), leakage currents into other sections,

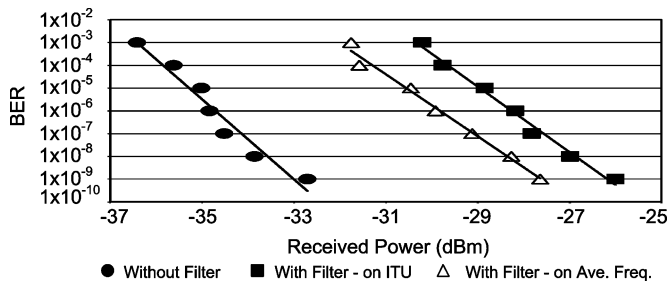

Fig. 4. BER versus received optical power.

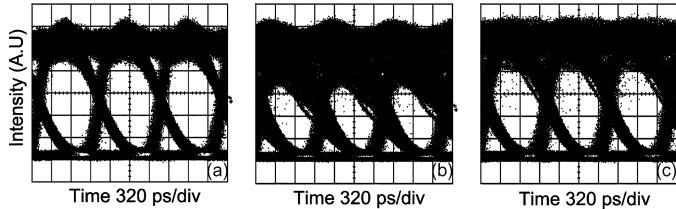

Fig. 5. Eye diagrams (a) without filter, (b) with filter centered at ITU wavelength, and (c) with filter centered at shifted frequency.

and thermal effects. Fig. 3 also highlights that increasing modulation index causes an increase in the settling time.

The effect of the frequency drift on the performance of a typical DWDM system is highlighted by the BER versus received power plot shown in Fig. 4. The case where no filter is used acts as the reference plot (\bullet). Alternatively, when the directly modulated signal is filtered with the filter centered at the target frequency of channel 38 on the ITU grid, the frequency deviations are converted into intensity fluctuations.

These intensity fluctuations cause degraded performance reflected by the incurred power penalty of 6.7 dB at a reference BER of 1×10^{-9} (\blacksquare). A slight improvement in performance (1.64 dB at reference BER of 1×10^{-9}), relative to the latter case, is obtained when the center frequency of the filter is moved to match the average shifted frequency when under modulation (193.343 THz) (\triangle). The recorded eye diagrams, shown in Fig. 5(a)–(c), further illustrate the BER degradation as described above. Fig. 5(a) shows the received eye where the directly modulated signal is received without a filter.

It is clearly seen that the eye is open and supports the excellent performance with received powers in the order of -33 dBm required to achieve a BER of 1×10^{-9} . This excellent performance could be attributed to the fact that even though the frequency drift exists, it does not manifest as intensity fluctuations without the presence of a frequency discrimination medium such as an optical filter. However, in the case of Fig. 5(b), the filter centered at the ITU frequency causes intensity fluctuations that result in a partially closed eye. It is important to note the comparative difference between these two eyes even though the closed eye is recorded at a higher received power of -30 dBm. Fig. 5(c) illustrates the eye at the same received power of -30 dBm where the filter center frequency is changed to the average shifted frequency, showing improved performance in comparison to Fig. 5(b).

IV. CONCLUSION

We have characterized the frequency drift of an SG DBR TL with an incorporated wavelength locker under the influence of direct modulation. The frequency offset has been recorded to vary from 13 to 19 GHz when the applied modulation index is changed from 0.1 to 0.6, respectively. We have gone on to show that, in DWDM systems, this drift may result in performance degradation as the signal passes through an optical filter. Results achieved show that a power penalty of 6.7 dB is incurred when using such a filter in comparison to the unfiltered case. A 1.64-dB improvement in performance (in comparison to the filtered case with filter centered at ITU frequency) is achieved when the center frequency of the filter is changed to match that of the average output frequency of the TL under direct modulation.

A marginal improvement in performance may be achieved if the modulation index is increased. However, this improvement in performance would be overshadowed by the penalty that the larger frequency offset would cause. Hence, a compromise would have to be drawn between the signal extinction ratio and the frequency offset. Another factor that might improve system performance would be a larger filter bandwidth, since the resultant intensity fluctuations due to the wavelength drift would be smaller. However, this would impose larger channel spacing within the WDM system. Here again, a trade-off exists between the optimum filter bandwidth and the channel spacing.

It is important to note that the limited modulation rate used is entirely due to the circuit and bonding parasitics. New device structures, with an optimized RF connection to the gain section, are currently being investigated. This would enable higher modulation rates to be applied to the device.

ACKNOWLEDGMENT

The authors would like to thank Intune-Networks for providing the custom built SG DBR laser that could be directly modulated.

REFERENCES

- [1] I. White, R. Penty, M. Webster, Y. J. Chai, A. Wonfor, and S. Shahkooh, "Wavelength switching components for future photonic networks," *IEEE Commun. Mag.*, vol. 40, no. 9, pp. 74–81, Sep. 2002.
- [2] J. E. Simsarian and L. Zhang, "Wavelength locking a fast-switching tunable laser," *IEEE Photon. Technol. Lett.*, vol. 16, no. 7, pp. 1745–1747, Jul. 2004.
- [3] L. A. Johansson, J. T. Getty, Y. A. Akulova, G. A. Fish, and L. A. Coldren, "Sampled-grating DBR laser-based analog optical transmitters," *J. Lightw. Technol.*, vol. 21, no. 12, pp. 2968–2976, Dec. 2003.
- [4] M. L. Majewski, J. Barton, L. Coldren, Y. Akulova, and M. C. Larson, "Direct intensity modulation in sampled-grating DBR lasers," *IEEE Photon. Technol. Lett.*, vol. 14, no. 6, pp. 747–749, Jun. 2002.
- [5] M. L. Majewski, J. Barton, and L. A. Coldren, "Widely tunable directly modulated sampled-grating DBR lasers," in *OFC 2002*, pp. 537–538, Paper ThV2.
- [6] Y. Liu, A. R. Davies, J. D. Ingham, R. V. Penty, and I. H. White, "Uncooled DBR laser directly modulated at 3.125 Gb/s as athermal transmitter for low-cost WDM systems," *IEEE Photon. Technol. Lett.*, vol. 17, no. 10, pp. 2026–2028, Oct. 2005.
- [7] E. Connolly, F. Smyth, A. K. Mishra, A. Kaszubowska-Anandarajah, and L. P. Barry, "Cross-Channel interference due to wavelength drift of tunable lasers in DWDM networks," *IEEE Photon. Technol. Lett.*, vol. 19, no. 8, pp. 616–618, Apr. 15, 2007.