

RATIONAL ANTI-MALARIAL DRUG DESIGN

by

Michael O'Donohoe, B.Sc. (Hons.)

A Thesis presented to Dublin City University for the degree of Doctor of Philosophy.

This work was carried out under the supervision of Dr. Peter Kenny,
School of Chemical Sciences, at Dublin City University.

August, 1998

I hereby certify that this material, which I now submit for assessment on the programme of study leading to the award of Ph.D is entirely my own work and has not been taken from the work of others save and to the extent that such work has been cited and acknowledged within the text of my work.

Signed: Michael O'Donohoe

ID No.: 93700300

Michael O'Donohoe

Date: 28/8/98

ACKNOWLEDGEMENTS-

I wish to thank my supervisor, Dr. Peter Kenny, for his help and guidance during this work.

I would also like to express my gratitude to:

Dr. John Dalton and his research group in the School of Biological Sciences, Dublin City University, for assistance with the biological assays.

My fellow postgraduate students and the academic and technical staff in the School of Chemical Sciences Dublin City University.

Dr. John Gallagher in the School of Chemical Sciences Dublin City University for the generation and analysis of crystallographic data.

Dr. Peter Caplan at the Mass Spectrometry laboratory, Faculty of Agriculture, U.C.D. for the high resolution EI mass spectra and Dr. Ron Orlando at the Complex Carbohydrate Research Centre, University of Georgia for the FAB mass spectra.

The "J118 Crew" both past and present - Mike, Karen, Mary, Dec, Teresa and Steve.

The "Core Group" and "Usual Suspects" - Guv, Toddler, Bob, Mick, Magpie, Shiny, Farmer, Davy, Donal, Darren and Keither.

Mr. Noel Jennings in Burmah Castrol (Ireland) Ltd. for his support while writing this thesis.

Special thanks to my parents Ann and Michael for their continuing support.

TABLE OF CONTENTS

Abstract.	6
Chapter one - Malaria - The disease.	7
Introduction.	7
1.1 The life-cycle of the malarial parasite.	9
1.2 The pathway of haemoglobin degradation in malarial parasites.	9
1.3 Anti-malarial drugs.	11
1.3.1 Quinoline methanols.	12
1.3.2 Phenanthrene methanols.	15
1.3.3 4-Aminoquinolines.	16
1.3.4 8-Aminoquinolines.	18
1.3.5 Drugs affecting the synthesis and utilisation of folate.	19
1.3.6 Other drugs with anti-malarial activity.	22
Chapter two - Protease inhibitors as potential anti-malarial drugs.	25
Introduction.	25
2.1 Proteases.	25
2.2 Aminopeptidases.	28
2.3 Protease inhibitors as potential anti-malarial drugs.	30
2.4 Aminopeptidase inhibitors.	34
Chapter three - Initial studies of amino acid derivatives as inhibitors.	43
Introduction.	43
3.1 <i>N</i> -Cinnamoyl and related derivatives.	44
3.2 <i>N</i> -3,5-Dinitrobenzoyl derivatives.	52
3.3 <i>N</i> -Toluene- <i>p</i> -sulphonyl derivatives.	55
3.4 <i>N</i> -3-Nitrophthaloyl derivatives.	57
3.5 <i>N</i> -Phenylureido derivatives.	59
3.6 <i>N</i> -Chloroacetyl derivatives.	60
3.7 Experimental.	62

Chapter four - Bidentate ligand inhibitors.	119
Introduction.	119
4.1 <i>N</i> -2-Hydroxy-2-phenylacetyl derivatives.	121
4.2 <i>N</i> -2-Hydroxy-3-phenylpropionyl derivatives.	129
4.3 <i>N</i> -3-Hydroxy-3-phenylpropionyl derivatives.	137
4.4 <i>N</i> -2-Thio-2-phenylacetyl derivatives.	141
4.5 Attempted synthesis of α -hydroxy- β -amino acid (AHBA) isosteres.	145
4.6 Experimental.	150
Chapter five - Biological results.	203
Introduction.	203
5.1 <i>N</i> -Cinnamoyl and related derivatives.	205
5.2 <i>N</i> -3,5-Dinitrobenzoyl derivatives.	208
5.3 <i>N</i> -Toluene- <i>p</i> -sulphonyl derivatives.	209
5.4 <i>N</i> -3-Nitrophthaloyl derivatives.	210
5.5 <i>N</i> -Phenylureido derivatives.	211
5.6 <i>N</i> -Chloroacetyl derivatives.	211
5.7 <i>N</i> -2-Hydroxy-2-phenylacetyl derivatives.	212
5.8 <i>N</i> -2-Hydroxy-3-phenylpropionyl derivatives.	214
5.9 <i>N</i> -3-Hydroxy-3-phenylpropionyl derivatives.	215
5.10 <i>N</i> -2-Thio-2-phenylacetyl derivatives.	216
5.11 Experimental.	218
Conclusion.	219
References.	220
Appendix I - List of abbreviations.	229
Appendix II - Publication	230
Appendix III - Crystallographic data.	231

RATIONAL ANTI-MALARIAL DRUG DESIGN

ABSTRACT

Malaria is a mosquito-borne disease caused by several species of *plasmodium* protozoa. It is one of the major killer diseases of the world, causing 2 million deaths annually. The most dangerous form is caused by *Plasmodium falciparum* with infections often ending terminally. Attempts to eradicate malaria have failed due to the emergence of drug resistant strains and thus there is a need for novel anti-malarial drugs.

Recently an identical aminopeptidase has been isolated from the both the human malarial parasite *P. falciparum* and the rodent malarial parasites *P. berghi* and *P. chabaudi*. It is significantly different in both size and structure to mammalian aminopeptidases and thus provides a prime target for chemotherapeutic intervention. Investigations were directed towards the design and synthesis of novel selective inhibitors of this enzyme.

Initially over forty amino acid and dipeptide derivatives with *N*- and *C*-terminal modifications were prepared. These included *N*-cinnamoyl, *N*-3,5-dinitrobenzoyl, *N*-toluene-*p*-sulphonyl, *N*-3-nitrophthaloyl, *N*-phenylureido and *N*-chloroacetyl amino acids, amino esters, amino amides and amino alcohols. The design rationale and synthesis of *N*-2-hydroxy-2-phenylacetyl, *N*-2-hydroxy-3-phenylpropionyl, *N*-3-hydroxy-3-phenylpropionyl and 2-thio-2-phenylacetyl amino acid derivatives are also presented, along with accompanying structure-activity analysis. The compounds were characterized by I.R. and N.M.R. spectroscopy, as well as high resolution M.S. X-ray crystallography was used to elucidate the crystal structures and hydrogen bonding interactions of two of the compounds.

All of the compounds were tested for inhibitory potency in a novel bioassay based on the liberation of fluorescent 7-amino-4-methyl-coumarin from L-leucine-7-amido-4-methyl-coumarin upon enzymatic hydrolysis of the amide bond. Many of the compounds possessed modest enzyme inhibitory potency in the micromolar range [3-nitrocinnamoyl glycine ethyl ester (**3c**); $IC_{50}=6.6\mu M$]. Some of the compounds also acted as potent activators of the aminopeptidase [3-nitrophthaloyl-L-leucine methyl ester (**10c**); activation at concentration of $10\mu M=132.8\%$]. The most effective inhibitor was *N*-2-thio-2-phenylacetyl phenethylamide (**30**) ($IC_{50}=5.2\mu M$).

CHAPTER ONE
MALARIA - THE DISEASE

Introduction

Malaria is a mosquito-borne disease which is caused by several species of *plasmodium* protozoa.^{1,2} It is probably older than mankind, its symptoms of intermittent fevers with enlargement of the spleen having been described in medical writings from the earliest times. The name malaria comes from the Italian “mal-aria”, meaning bad air, which refers to the association of the disease with the foul-smelling air of the Tiberian marshes. The four plasmodial species that are pathogenic to man are *Plasmodium falciparum*, *P. vivax*, *P. malariae* and *P. Ovale*. These organisms produce respectively, malignant tertian malaria, benign tertian malaria, quartan malaria and a milder form of benign tertian malaria.³⁻⁵ *P. falciparum* and *P. vivax* are the most common, accounting for 93% of malarial infections in the world.² *P. falciparum* is the most dangerous of the plasmodial species, with infections often ending terminally. This is because of the tendency of the erythrocytic parasite to clump together, adhering to capillary walls, and restricting blood flow in the vessels of the heart, intestine, brain or bone marrow. Malaria is one of the major killer diseases of the world, causing over 2 million deaths annually.⁶

During the 1950's and 1960's the World Health Organisation attempted to eradicate malaria from most parts of the world where it was prevalent. By the end of the 1950's, the incidence of the disease had dropped dramatically from the originally estimated 250 million cases per year. However for various reasons not only more virulent strains but also economic and administrative problems, during the 1970's it became obvious that the eradication attempt had failed. The 1988 estimate of the number of new malaria infections globally was 210-220 million per year.³ About 85% of these cases were malignant malaria, caused by the most dangerous of the malaria parasites *Plasmodium falciparum*.

At present about 46% of mankind is at risk from malaria because they live in malarious areas³ (fig 1.1). Some cases are even seen in the western world due to the ease of modern air travel. It is clear that the design of novel and potent anti-malarial drugs is of the utmost importance in controlling the disease, especially with the emergence of new drug-resistant strains.⁶

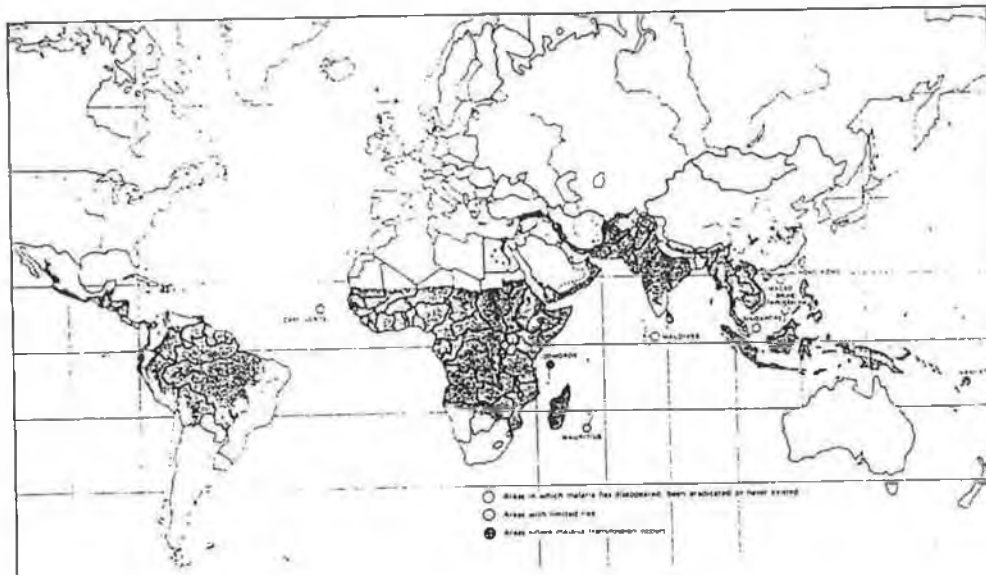

Fig. 1.1 World distribution of malaria.⁶

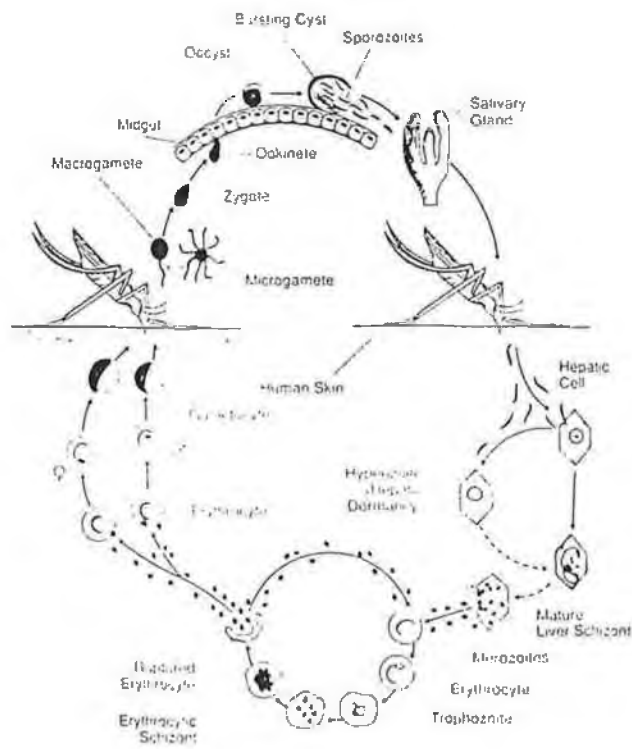

Fig. 1.2 The lifecycle of the malarial parasite.⁶

1.1 The life-cycle of the malarial parasite

The life cycle of the malarial parasite consists of a sexual stage which takes place in the female *Anopheles* mosquito and an asexual stage which takes place in humans (fig 1.2).¹ When a female mosquito bites a human, sporozoites are injected into the blood stream with some anticoagulant saliva. Within an hour they disappear from the blood into the parenchymal cells of the liver where during the next 10-14 days they develop and multiply. The liver cells then rupture releasing merozoites which enter the red blood cells and form motile intracellular parasites called trophozoites.

Following mitotic replication, the parasite in the blood cell is called a schizont and its growth and division schizogony which results in the release of further merozoites when the blood cell ruptures. It is at this stage that the symptoms of malaria appear as the parasite degrades the hosts haemoglobin in order to replicate itself and it is also at this stage that clinical cure malarial drugs act. In certain forms of malaria some sporozoites form resting forms of the parasite called hypnozoites on entering the liver cells which can be reactivated at a later stage. Some merozoites on entering red blood cells differentiate into male and female gametocytes which can only complete their life cycle when taken up by the mosquito when it sucks the blood of the infected host.

Malaria parasites can multiply in the body rapidly, for example a single parasite of *Plasmodium vivax* can give rise to 250 million merozoites in two weeks. In chemotherapeutic terms this means that if a drug destroys 94% of the parasites every 48hrs it will only maintain equilibrium and will not reduce their number or their ability to multiply.³

1.2 The pathway of haemoglobin degradation in malarial parasites

During intra-erythrocytic development the malaria parasite degrades the haemoglobin of the host and uses the peptide fragments to replicate itself.⁷ Haemoglobin appears to be the main source of most amino acids as parasite growth in semi-defined media requires few exogeneous amino acids.⁸ It has been estimated that 25-75% of the haemoglobin in an infected erythrocyte is degraded by the parasite.^{9,10} An ordered pathway

exists that efficiently breaks down haemoglobin to yield amino acids which the parasite uses as a nutrient source. The enzymes involved are specific and present prime targets for chemotherapeutic intervention.^{11,12}

Haemoglobin is ingested by the intra-erythrocytic parasite via a mouth-like structure called a cytosome. Vesicles form around the blood cell cytosol and carry it off to the acidic (pH 5.0-5.5) digestive vacuole.^{13, 14} The vesicle is then lysed and the globin broken down to amino acids. In *plasmodia* there are many proteases many of which can degrade haemoglobin *in vitro*.

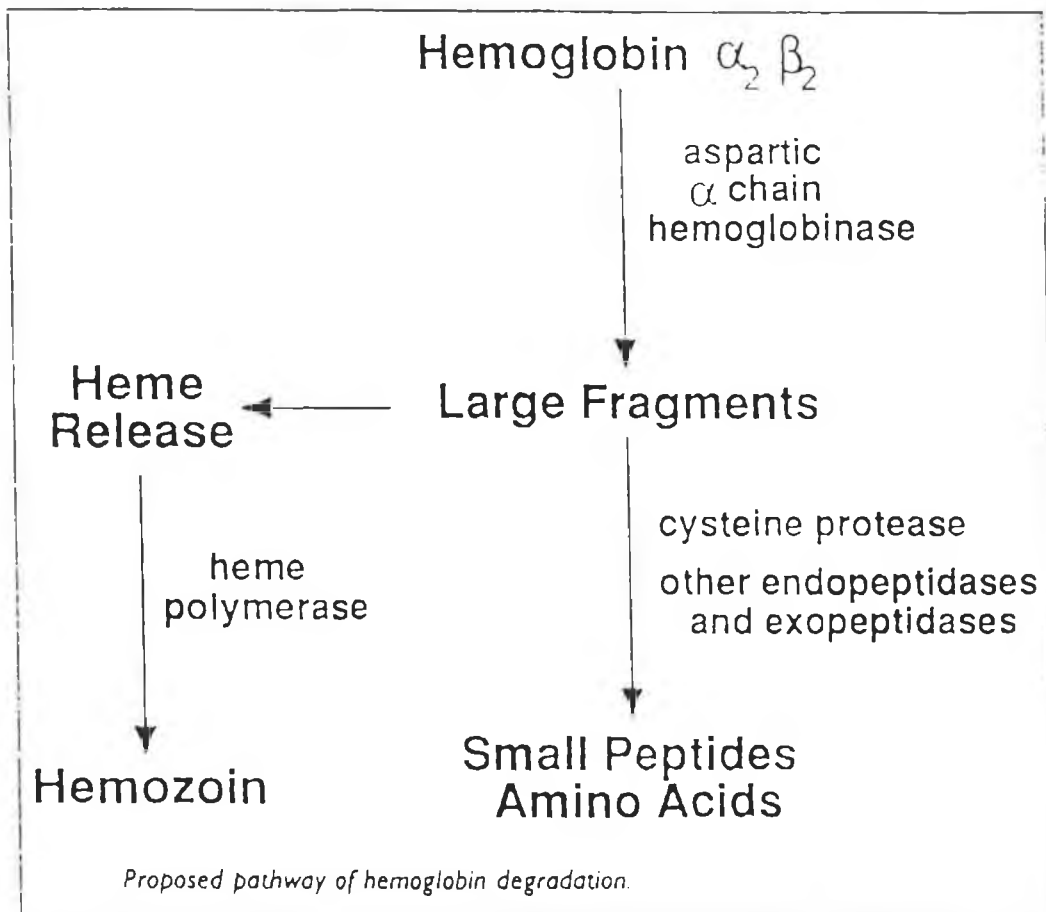

Fig. 1.3 The pathway of haemoglobin degradation by the malarial parasite.¹²

Physiologically initial cleavage of the haemoglobin into large fragments is found to proceed in the presence of a group of aspartic, serine, cysteine, and metalloproteases.¹⁵⁻¹⁹ When pepstatin a specific aspartic protease inhibitor was added to parasites growing in culture proteolysis was prevented. Further proteolysis to small peptides could be partially inhibited by specific cysteine protease inhibitors. This suggests that the initial action is by an aspartic protease followed by a cysteine protease and perhaps others (fig 1.3). This is complicated by the presence of an enzyme called heme polymerase which converts the heme moiety of haemoglobin to insoluble hemozoin, or malarial pigment.⁸ If this did not occur, the ferrous form would be converted to the toxic ferric form which can cause damage to biological membranes and inhibit enzymes such as proteases.

A recent study has shown the presence of only a single aminopeptidase in cell-free extracts of *Plasmodium falciparum*, *Plasmodium berghei*, and *Plasmodium chabaudi*.²⁰ A comparative study of the aminopeptidase activity in each extract revealed that the enzymes have similar substrate specificity and kinetics. The three enzymes were selectively inhibited by *o*-phenanthroline and are thus metallo-aminopeptidases. However in contrast to other aminopeptidases the metal co-factor did not appear to be Zn²⁺. Since recent research has shown that only a single aminopeptidase is present in all *plasmodia* species this seems to be the perfect target for a chemotherapeutic agent. In addition the fact that it is different to mammalian aminopeptidases in both size and structure, may improve the chances of designing a drug which selectively inhibits the malarial enzyme.

1.3 Anti-malarial drugs

Anti-malarial drugs are classified depending on the stage of the parasite's life-cycle in which they are active. Clinical cure anti-malarial drugs are blood schizonticidal agents which are effective against the erythrocytic forms of the *plasmodium* organism. This classification includes quinoline methanols [e.g. quinine (fig. 1.4) and mefloquine (fig. 1.5)], the 4-aminoquinolines [e.g. chloroquine (fig. 1.7)], and agents that interfere with the synthesis of folate [e.g. sulphadoxine (fig. 1.12)] or with its action [e.g. pyrimethamine (fig.

1.9)]. Combinations of these drugs are often used, sometimes with antibiotics such as tetracycline (fig. 1.15) and clindamycin (fig. 1.16).

Radical cure anti-malarial drugs are tissue schizonticidal agents which are effective against the parasites in the liver. Only the 8-aminoquinolines [e.g. primaquine (fig. 1.8)] have this action. These drugs also destroy gametocytes and thus reduce the spread of infection.

Drugs used for suppressive prophylaxis are drugs which prevent the development of malarial attacks. True causal prophylaxis (the prevention of infection by destroying the sporozoites on entry into the host) is not feasible with the drugs in present use. Prevention of the development of clinical attacks can however be effected by drugs which kill the parasites when they emerge from the liver. The drugs used for this purpose are mainly those listed as clinical cure anti-malarial drugs

1.3.1 Quinoline methanols

Quinine

Quinine^{3-5,21} (fig. 1.4) is the chief alkaloid obtained from the bark of various species of *Cinchona* trees which are indigenous to certain regions of South America. It was first isolated in 1820 by two French chemists, Pierre Joseph Pelletier and Joseph Bienaime Caventou. Synthetic quinine was first prepared by Woodward²² and is now principally used for the oral treatment of chloroquine-resistant *P. falciparum* malaria. The drug is formulated as quinine sulphate for oral use and as quinine dihydrochloride for parenteral use.

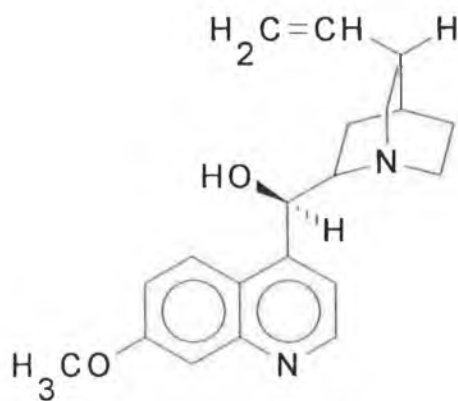

Fig. 1.4 Quinine.

Anti-malarial action

Quinine is a rapidly acting highly effective blood schizonticide against the four malaria parasites. Quinine has no effect on sporozoites of the liver stages of any of the parasites. The mechanism of action is unclear, however it is known to depress many enzyme systems. It also forms a hydrogen complex with double-stranded DNA that inhibits the strand separation, transcription, and protein synthesis. The secondary alcohol group is essential for activity.

Clinical uses

Quinine dihydrochloride is given slowly intravenously for the parenteral treatment of severe *P. falciparum* malaria. It is administered orally as quinine sulphate for the treatment of attacks of *P. falciparum* malaria resistant to chloroquine, however it must be used in combination with other drugs as quinine alone fails to completely eliminate the infection. Because of its potential toxicity quinine is generally not used in prophylaxis except in cases of resistance to chloroquine and pyrimethamine-sulphadoxine.

Adverse effects

When taken orally quinine commonly causes gastric irritation. Therapeutic doses can sometimes cause hypoglycaemia through stimulation of the pancreatic B cell release of insulin, particularly in severe infections and pregnant patients. However recently the role of quinine in causing hypoglycaemia has been called into question.^{23,24} Cinchonism is the toxic state that usually develops when plasma levels of quinine exceed 7-10µg/ml.

Symptoms of mild to moderate cinchonism include headache, nausea, slight visual disturbances and dizziness. Severe toxicity is rare and is associated with fever, skin eruptions, deafness, visual abnormalities and central nervous system effects.

Mefloquine

General

Mefloquine³⁻⁵ (fig. 1.5) is a schizonticidal agent with a long plasma half-life (>30 days), which may be due to active metabolites. It is related to quinine, but unlike quinine, it does not intercalate DNA. It may be a valuable drug for the treatment of multi-resistant *P. falciparum* malaria particularly if combined with sulphadoxine and pyrimethamine. Because of its long half-life it can be given every two weeks for suppressive prophylaxis.

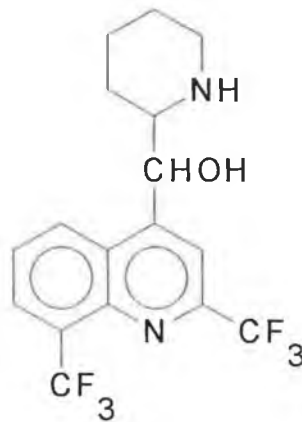

Fig. 1.5 Mefloquine.

Anti-malarial action

Mefloquine has a strong blood schizonticidal activity against *P. falciparum* and *P. vivax* but is not active against *P. falciparum* gametocytes or the hepatic stages of *P. vivax*. The mechanism of action is not known and resistance can occur rapidly. Resistant strains have been found in areas where the drug has never been used.

Clinical uses

Mefloquine is effective in prophylaxis against most strains of chloroquine-resistant or pyrimethamine-sulphadoxine-resistant *P. falciparum* malaria, and is curative when taken weekly for four weeks after leaving an endemic area. When used for this purpose the drug also provides prophylaxis against *P. vivax*, and probably against *P. ovale* and *P. malariae*.

Adverse effects

In prophylactic doses minor effects include gastrointestinal disturbances, headaches and dizziness. Ophthalmological lesions were seen in rats given daily doses, and daily doses of 160mg/kg was found to be embryotoxic in rabbits

1.3.2 Phenanthrene methanols

Halofantrine

General

Halofantrine³ (fig 1.6) is a blood schizonticidal drug. It was discovered during the Second World War but was not developed when chloroquine was found to be successful. However since the development of chloroquine resistance in *plasmodia* there has been renewed interest in the use of halofantrine. Its mode of action however is unknown.

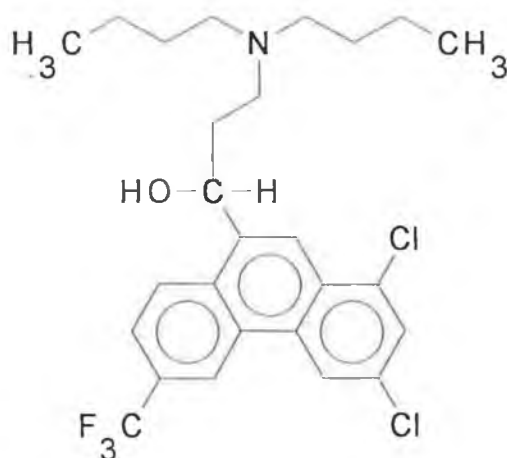

Fig. 1.6 Halofantrine.

Clinical uses

It is active against strains of *P. falciparum* that are resistant to chloroquine, pyrimethamine and quinine and is also effective against erythrocytic forms of *P. vivax* but not the hypnozoites. Cross-resistance with mefloquine has been reported. The half-life of the parent drug is 1-2 days and that of the active metabolite is 3-5 days.

Adverse effects

Common unwanted effects include abdominal pain, gastrointestinal tract disturbances and headache. Serious cardiac problems can sometimes occur.

1.3.3 4-Aminoquinolines

Chloroquine

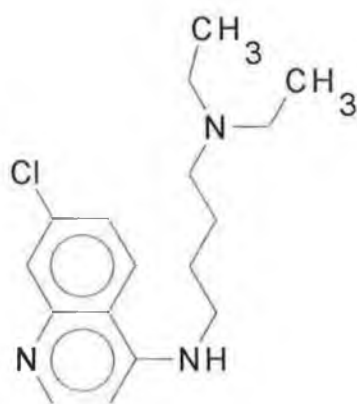

Fig. 1.7 Chloroquine.

Anti-malarial action

Chloroquine^{3-5,21} (fig. 1.7) is a highly effective blood schizonticide and the 4-aminoquinoline most widely used to prevent or terminate attacks of *P. vivax*, *P. ovale*, *P. malariae* or sensitive *P. falciparum* malaria. It is also moderately effective against

gametocytes of *P. vivax*, *P. ovale* and *P. malariae*, but not those of *P. falciparum*. It was developed because of a need for synthetic quinine substitutes during both World Wars.²⁵ The exact mechanism of anti-malarial action has not been determined but it may function by blocking the enzymatic synthesis of DNA and RNA to both mammalian and protozoal cells and forming a complex with DNA that prevents replication or transcription to RNA. It may also bind to heme forming a complex which is toxic to the parasite.^{26,27,28} Within the parasite the drug concentrates in vacuoles and raises the pH of those organelles,^{13,14} interfering with the parasite's ability to metabolize and utilize erythrocyte haemoglobin.²⁹ Interference with the phospholipid metabolism has also been proposed as a mechanism.^{30,31}

Clinical uses

Chloroquine is the preferred drug for prophylaxis against all forms of malaria except in regions where *P. falciparum* is resistant to 4-aminoquinolines. It usually terminates the fever of acute malarial attacks in 24-48 hours and for *P. falciparum* and *P. malariae* infections a complete cure can be obtained. However the drug has no effect on secondary tissue schizonts of relapsing malarials and thus cannot effect a radical cure of infections caused by *P. vivax* or *P. ovale*.

Adverse effects

Gastrointestinal symptoms, mild headaches and anorexia may result. Taking the drug after meals may reduce some adverse effects. Rare reactions observed include haemolysis in glucose-6-phosphate deficient patients, impaired hearing, confusion, psychosis, convulsions and hypertension.

1.3.4 8-Aminoquinolines

Primaquine

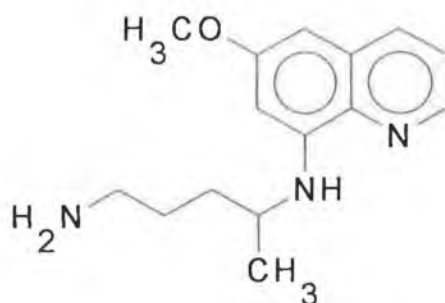

Fig. 1.8 Primaquine.

Anti-malarial action

Primaquine^{3-5,32} (fig. 1.8) is the most commonly used and least toxic of the 8-aminoquinoline anti-malarial drugs. The 8-aminoquinolines differ from the previously discussed anti-malarials in that they have no activity against erythrocytic schizonts. They are thus usually used in conjunction with another anti-malarial drug such as chloroquine. They kill sexual forms in the blood and are active against the pre-erythrocytic and para-erythrocytic forms in the liver and spleen. They bind to DNA and their anti-plasmodial activity is probably due to this. They also cause the mitochondria of cultured exoerythrocytic forms to swell and become vacuolated, but it is not known whether a mitochondrial site of action contributes to anti-malarial activity *in vivo*.

Clinical uses

Primaquine is always given orally usually as the phosphate. Unlike the 4-aminoquinolines it does not bind to tissues and due to its rapid metabolism daily doses are necessary. It is mainly used for the radical cure of relapsing malarias.

Adverse effects

Most patients tolerate primaquine well but occasionally mild gastrointestinal upsets are produced. Haemolytic anaemia is caused in patients who are glucose-6-phosphate sensitive.

1.3.5 Drugs effecting the synthesis and utilisation of folate

General

This group include both folate antagonists and agents which inhibit the synthesis of folate. The former act by inhibiting dihydrofolate reductase and includes pyrimethamine (fig. 1.9), proguanil (fig. 1.10) and trimethoprim (fig. 1.11), the latter by competing with *p*-aminobenzoic acid and includes sulphadoxine (fig. 1.12) and dapsone (fig. 1.13).

Pyrimethamine and Proguanil

Pyrimethamine³⁻⁵ (fig. 1.9) in fixed combination with sulphadoxine is used in a single dose treatment of chloroquine-resistant *P. falciparum* malaria, however because of the toxicity of the combined drug it is no longer used in prophylaxis. Proguanil³⁻⁵ (fig. 1.10) is used in some regions of the world for malaria prophylaxis particularly when used in combination with chloroquine.

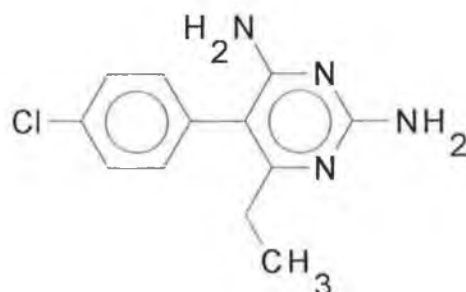

Fig. 1.9 Pyrimethamine.

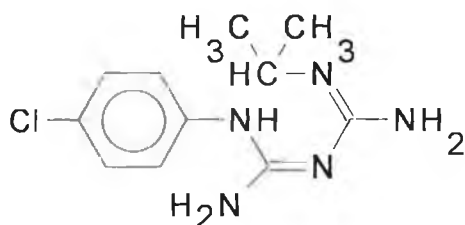

Fig. 1.10 Proguanil.

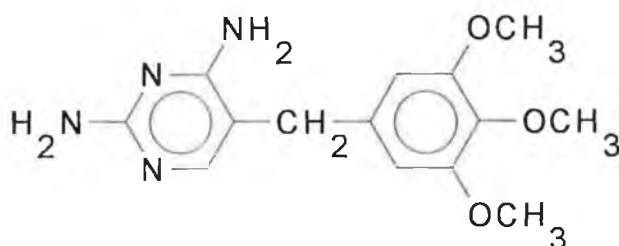

Fig. 1.11 Trimetoprim.

Anti-malarial action/Clinical uses

Pyrimethamine and proguanil are blood schizonticides active against susceptible *plasmodia*, however because they act more slowly than chloroquine or quinine they can only be used in prophylaxis not in treatment. Neither drug is adequately gametocidal nor effective against the persistent liver strains of *P. vivax*. Resistant strains of *P. falciparum* have appeared world-wide wherever pyrimethamine and proguanil have been extensively used. Resistant strains of *P. vivax* have appeared less frequently. Therefore prophylaxis against *P. falciparum* malaria with either drug alone is no longer recommended.

Adverse effects

Most patients tolerate pyrimethamine and proguanil well. Gastrointestinal and allergic reactions are rare. Formerly pyrimethamine was not recommended during

pregnancy because the drug is teratogenic in large doses in some animals. However it has been widely used in humans for over 20 years and such effects have not been reported.

Sulphadoxine and Dapsone

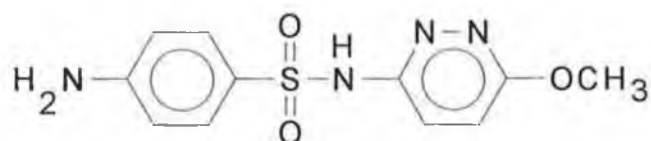

Fig. 1.12 Sulphadoxine.

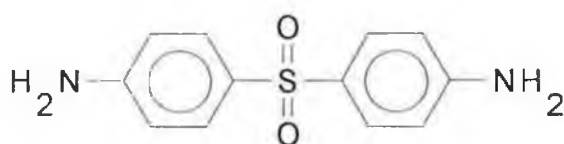

Fig. 1.13 Dapsone.

Sulphadoxine³⁻⁵ (fig. 1.12) and dapsone³⁻⁵ (fig. 1.13) compete with *p*-aminobenzoic acid in the synthesis of folic acid. Since this is an essential step in *plasmodia* they may be expected to display anti-malarial activity. They are not as potent as other anti-malarials but are therapeutically useful when used in conjunction with inhibitors of dihydrofolate reductase especially in chloroquine-resistant infection by *P. falciparum*.

1.3.6 Other drugs with anti-malarial activity

Artemisinin (Qinghaosu)

Artemisinin^{3,5,33} (fig. 1.14) is an unusual heterocyclic compound which has been isolated from the chinese herb *Qinghao* (*Artemisia annua*). It is believed to be a prodrug, its activity being due to the metabolite dihydroartemisinin. Several derivatives of dihydroartemisinin, namely arthemether, artheether and artesunate are currently undergoing clinical trials.³⁴ The most unusual feature of its chemical structure is the 1,2,4-trioxane ring, the only example found in nature.

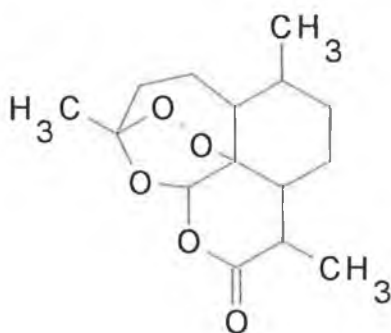

Fig. 1.14 Artemisinin.

It has rapid blood schizonticidal activity against all types of human malarias³⁵ and its mode of action is thought to involve an oxidative mechanism affecting changes both to red blood cells and the membranes of the malarial parasite.³⁶ It may also involve damage to the parasite membranes by free radicals.³⁷ The peroxide bridge is essential for activity. It has no effect on hepatic stages and therefore cannot cure the relapsing malarias. It is effective against chloroquine resistant *P. falciparum* malaria and has been especially useful in cerebral malaria.^{38,39} Its major disadvantage is the high rate of recurrence of malaria and thus it is recommended that it be used in conjunction with an antifolate. Research has shown that *N*-alkylzaartemisinin derivatives have greater activity than the parent compound.^{40,41} Some structurally simple tricyclic trioxanes have been synthesized with extraordinary antimalarial activity.^{42,43} Alkylamino and benzylamino ether

derivatives of artemisinin have also shown enhanced activity.⁴⁴ The weakly basic side chains probably assist accumulation of the molecules in the acidic food vacuole

Tetracycline and clindamycin

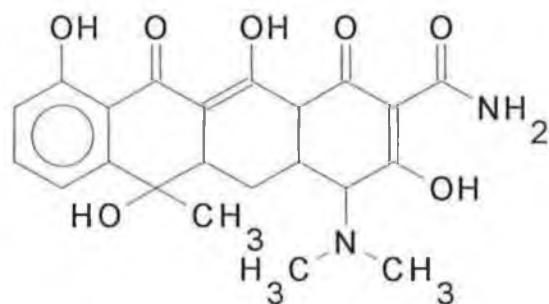

Fig. 1.15 Tetracycline.

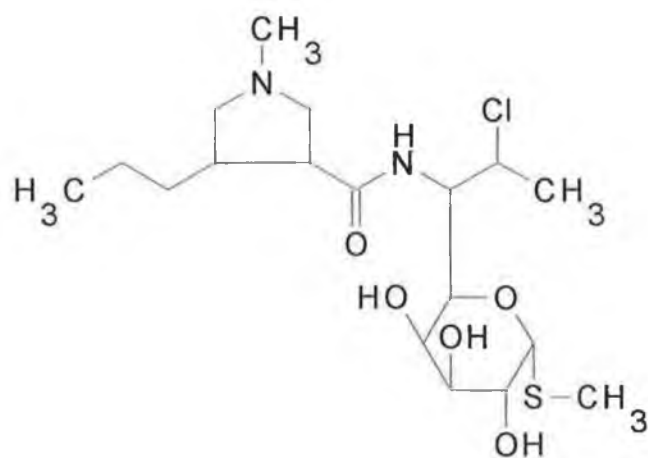

Fig. 1.16 Clindamycin.

Tetracycline³⁻⁵ (fig. 1.15) was originally thought to have little value other than as an antibacterial drug. However the emergence of chloroquine-resistant drugs has led to a re-examination of previously discarded remedies. It acts by binding to both the mRNA and the 30S subunit of ribosomes, the latter being the binding site of importance in its ability to inhibit protein synthesis. Tetracycline has been shown to have a useful role when used in combination with standard anti-malarial drugs. Tetracycline can clear asexual forms of the parasite in 7 days, but has no effect against the gametocytes.

Clindamycin³⁻⁵ (fig. 1.16) is another antibiotic which has been shown to have a useful role in the treatment of malarial infection. It probably acts by binding to the 50S ribosomal subunit, thus inhibiting the correct attachment of the amino acid end of the aminoacyl tRNA to this subunit.

CHAPTER TWO

PROTEASE INHIBITORS AS POTENTIAL ANTI-MALARIAL DRUGS

Introduction

As we have seen the dream of eradicating malaria totally from most parts of the world has gradually faded before the grim realities of drug resistant-malarial strains and insecticide-resistant mosquitoes which have led to malaria making a comeback with renewed vigour sometimes surpassing earlier recorded levels. In truth there are fewer tools with which to combat malaria today than there were 20 years ago and few believe that global eradication of malaria will be possible in the foreseeable future. Although the production of an anti-malarial vaccine is an exceptionally attractive strategy for preventing and controlling malaria,⁴⁵⁻⁴⁷ many obstacles prevent its development and even if a safe vaccine was developed this would not negate the necessity of developing new anti-malarial drugs such is the enormity of the problem. Because at the moment, malaria is predominantly seen as a Third World problem (in the future this may not be the case) pharmaceutical companies are unwilling to spend research funds on something they view as being economically unfavorable. To western governments this is a false economy because not only is the global advance of malaria expensive in terms of foreign aid, it also threatens to invade temperate countries which have been malaria-free for centuries. The onus thus rests mostly on small research groups to carry out studies both into the malarial parasite itself and to develop novel drugs to control its proliferation. The proteases which *plasmodia* employ to degrade haemoglobin provide excellent targets for chemotherapy.

2.1 Proteases

Proteases are enzymes which cleave peptide bonds (fig 2.1). Four major classes of proteases are known and are designated by the principal functional group in their active site namely serine, cysteine, aspartyl and metalloproteases.⁴⁸⁻⁵¹ Proteases do not rely simply on binding interactions to catalyze cleavage of peptide bonds but also

use crucial polar groups with functional roles. These groups have distinct roles to play in the four classes, and four ways of catalyzing the same chemical reaction (i.e. the hydrolysis of the amide bond) exist.

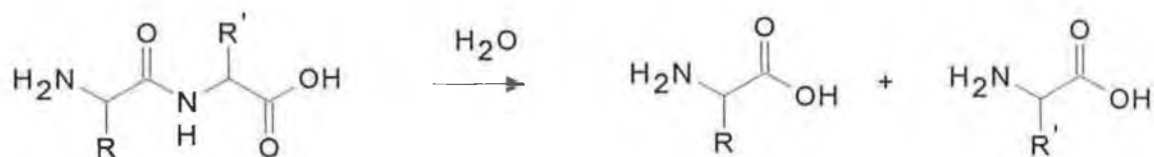
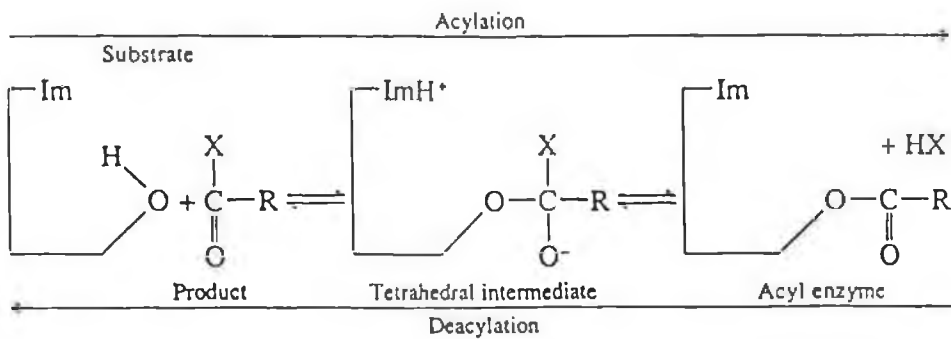
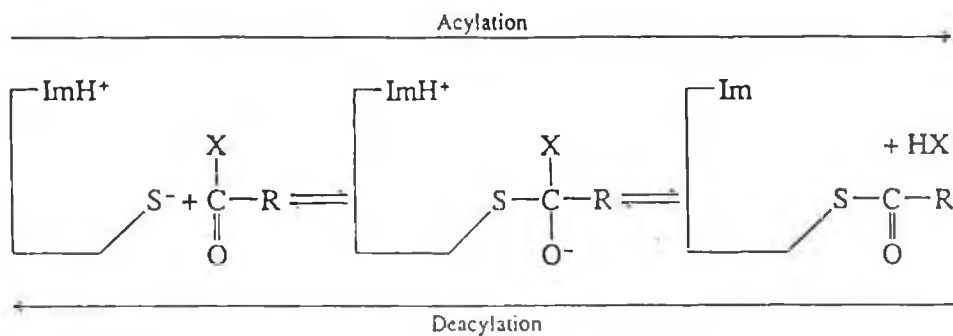

Fig. 2.1 Hydrolysis of the amide bond.

In spite of the differences in catalytic mechanisms, the enzymes of the four classes share a common property of going through an intermediate in which the normally trigonal carbonyl carbon becomes tetrahedral due to the temporary addition of a nucleophile (fig 2.2). In the case of the serine and cysteine proteases the nucleophile is the serine hydroxyl or the cysteine thiol, whereas in the aspartyl and metalloproteases, it is a water molecule which hydrolyses the peptide bond. The reaction proceeds more directly in the latter two classes because the acyl-enzyme intermediate that occurs with the serine and cysteine proteases must be hydrolysed by water in a second step.



A Serine protease



B Thiol protease

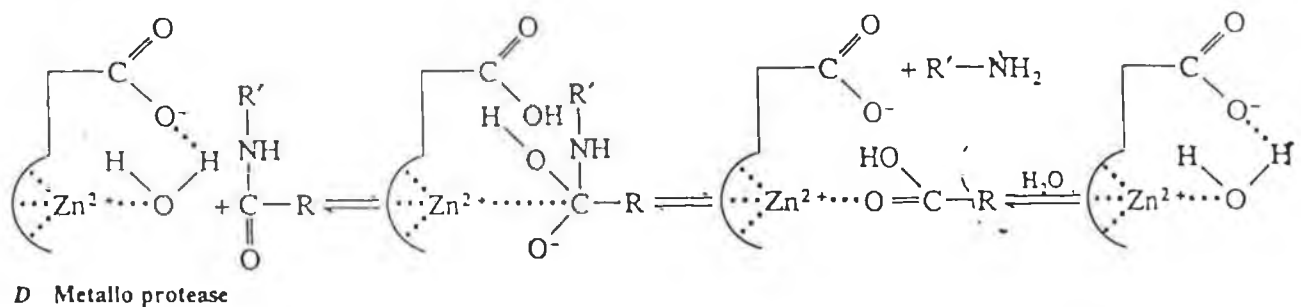
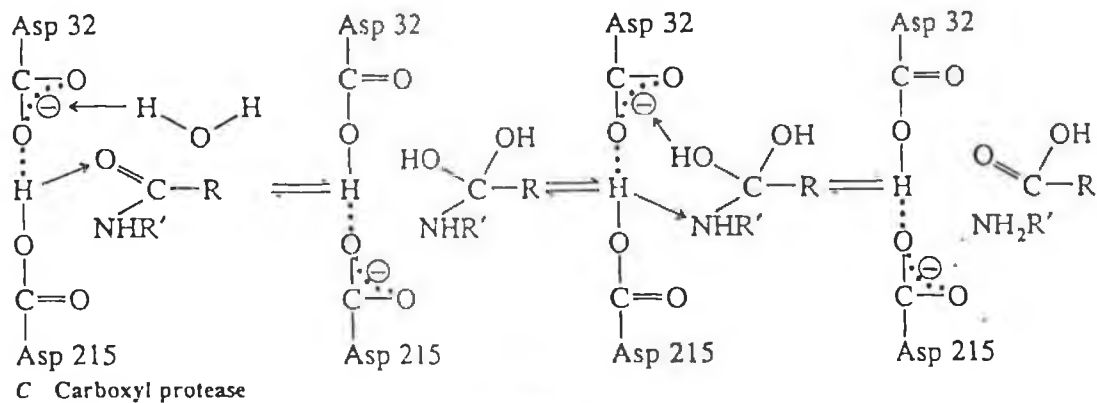

Fig. 2.2 Mechanism of action of the four classes of proteases.⁴⁹

2.2 Aminopeptidases

Aminopeptidases are a class of metalloproteases which cleave peptide bonds sequentially from the *N*-terminus of the peptide chain.⁵⁰ They generally require a free α -amino or α -imino group and release free amino acids from the *N*-terminus of the peptide substrate. The metal ions bound to the enzymes act as electrophilic centres in catalytic reactions. This is important because the side chains of the amino acid residues in the enzyme may only act as acids, bases, or nucleophiles and cannot provide this function. The transition metals Fe^{2+} , Co^{2+} , Cu^{2+} , Mg^{2+} and Zn^{2+} are among the metal ions found at the active sites of metalloenzymes. The catalytic function of the metal ion often depends on polarization of the substrate through the formation of a complex between the substrate and the metal ion. In aminopeptidases the metal co-factor is usually Zn^{2+} , but as has already been stated this does not seem to be true for the aminopeptidase isolated from the malarial parasite. Studies have shown that when the active site metal of the malarial aminopeptidase was removed with *o*-phenanthroline, the activity of the enzymes could be restored to 30-50% of the control value with 10 μM concentrations of Mn^{2+} , Ca^{2+} and Mg^{2+} , whereas a concentration of even 1000 μM of Zn^{2+} did not restore activity.²⁰

A mechanism for the action of leucine aminopeptidase has been reported.⁵² The metal ion mediated the binding of the substrate to the enzyme and secondary interactions between the substrate and enzyme have been shown to exist. The substrate binds to the metal ion via the free amino group and the amide or ester carbonyl oxygen (fig 2.3a). The formation of this ternary substrate-metal ion-enzyme complex would not enhance the rate of hydrolysis and so a water binding site is needed to allow addition of water to the susceptible carbonyl bond. This results in a tetrahedral adduct as opposed to the planar peptide group of the substrate. The second stage of the reaction is the decomposition of the adduct (fig 2.3b). This may be assisted by the interaction of the peptide nitrogen or ester oxygen with an acid group. An interaction of this sort would not be expected for the substrate because of the resonance of the peptide bond which makes the lone pair unavailable. However

no such resonance exists in the adduct, and interaction with an acid group should occur much more readily.

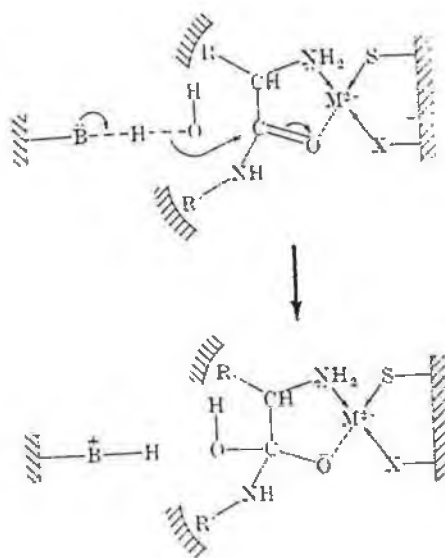

(a)

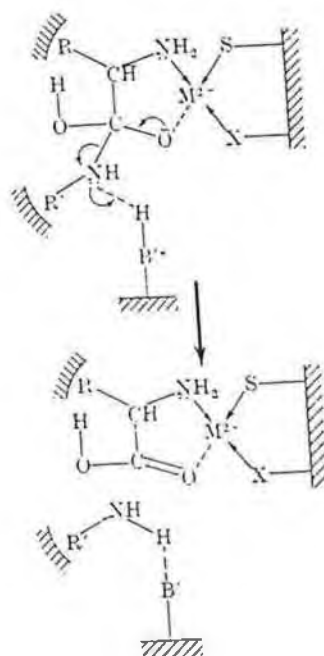

(b)

Fig. 2.3 The mechanism of action of leucine aminopeptidase.⁵²

2.3 Protease inhibitors as potential anti-malarial drugs

As has already been stated, the specificity of the protease enzymes that malarial parasites employ to degrade haemoglobin provide an attractive target for the design of novel anti-malarial drugs. The aspartic protease inhibitor pepstatin⁵³ (fig. 2.4) prevents the degradation of haemoglobin by *plasmodia* species.¹¹

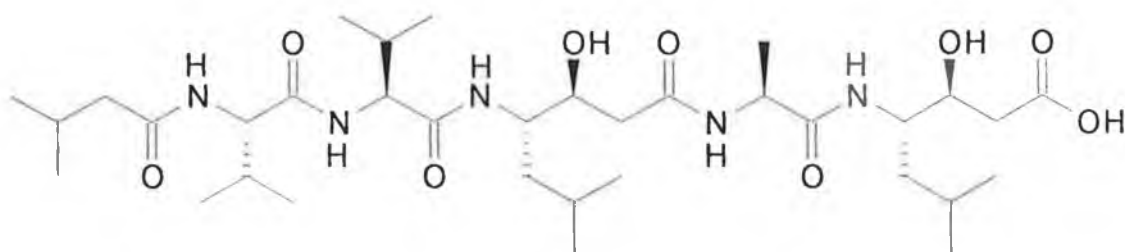

Fig. 2.4 Pepstatin.

Pepstatin is a low molecular weight transition state analogue inhibitor, which contains the novel amino acid statine ((3*S*,4*S*)-4-amino-3-hydroxy-6-methylheptanoic acid). A convenient synthesis of statine starting from L-leucine has been described.^{54,55}

It is known that leupeptin (an inhibitor of cysteine and serine proteases), blocks haemoglobin degradation in the trophozoite food vacuole¹⁸ and suppresses the symptoms of malaria.⁵⁶ Leupeptin (fig. 2.5) is a naturally occurring protease inhibitor isolated from various species of *actinomyces*.⁵⁷

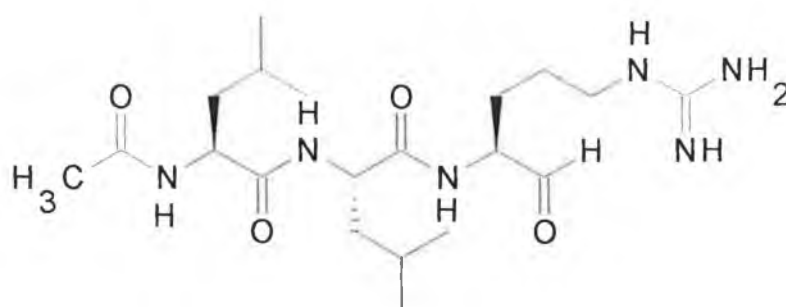

Fig.2.5 Leupeptin.

Leupeptin is a transition state analogue inhibitor which exists in three covalent forms in aqueous solution.⁵⁸ Its mode of action involves firstly binding non-covalently to the active site, and then in a second step it reacts with the active site nucleophile to form a hemiacetal or hemithioacetal. Leupeptin is not selective among enzymes of similar substrate specificities and its use as a therapeutic agent is thus limited, however derivatives of leupeptin might show selectivity. Early work by Ito and co-workers⁵⁹ showed that the specificity of leupeptin analogues is determined by the side-chain structure of the *C*-terminal aldehyde and the composition and sequence of the peptide as a whole. Several *C*-terminal aromatic aminoaldehydes were synthesized by DIBAL (diisobutylaluminium hydride) reduction of the corresponding *Z*-protected amino acid esters⁶⁰ followed by deprotection and coupling. *N*-terminally modified analogues synthesized by Saino *et al*⁶¹ containing a *C*-terminal arginal functionality showed dramatic increases in the inhibition of certain enzymes in comparison to leupeptin. The synthesis of these inhibitors involved a semisynthetic route via the enzymatic cleavage of arginal dibutyl acetal from protected leupeptin.⁶² More recent studies describe the synthesis of several tripeptide analogues of leupeptin containing *C*-terminal arginal, lysinal or ornithinal units.^{63,64} The three amino aldehyde derivatives were synthesised via DIBAL reduction of the corresponding *Z*-protected amino acids. The aldehydes were converted to the semicarbazones, deprotected, and then coupled to a series of *Z*-protected dipeptide acids. The synthetic analogues were tested as inhibitors of trypsin, plasmin, and kallikrein and showed significant variation in selectivity.

E-64 (*L-trans*-epoxysuccinyl-leucylamido-4-guandino-butane)^{65,66} (fig. 2.6), is another cysteine protease inhibitor which blocks haemoglobin degradation by the malaria parasite.¹⁸ It acts by alkylating the catalytic cysteine thiol⁶⁷ and it has been proposed that the free carboxylate α to the epoxide both positions and activates the epoxide for alkylation by the cysteine thiol.⁶⁸

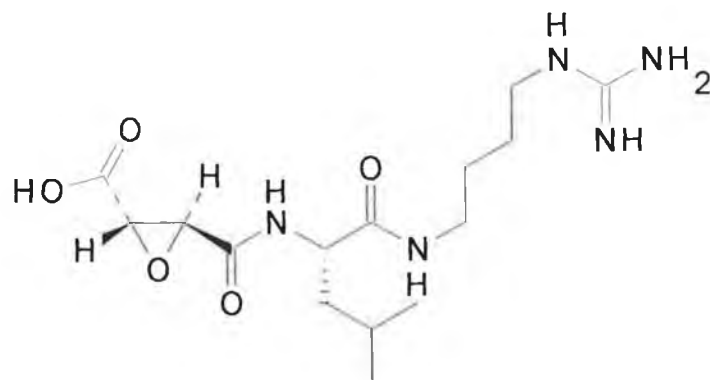

Fig. 2.6 E-64.

The inhibitory effects of E-64 and its analogues have been described^{69,70} It was found that E-64 inhibited all of the cysteine proteases tested but none of the other classes of enzymes. It is not however a general cysteine protease, but shows selectivity for papain, other plant enzymes and the lysosomal cysteine proteases.

Rosenthal and co-workers^{71,72} showed that the trophozoite cysteine protease had a similar biochemistry to the lysosomal enzymes cathepsin B and cathepsin L with a similar pH optimum for activity. It was efficiently inhibited by highly specific peptidyl fluoromethylketone inhibitors (general structure shown in fig. 2.7) of cathepsin B and L. Micromolar concentrations of the fluoromethylketone inhibitor Z-Phe-Ala-CH₂F blocked the degradation of haemoglobin in the trophozoite and much larger concentrations were found not to be toxic in mice due to the low reactivity of these enzymes outside the inhibitor-enzyme complex. This suggests that these inhibitors may have potential as anti-malarial drugs.

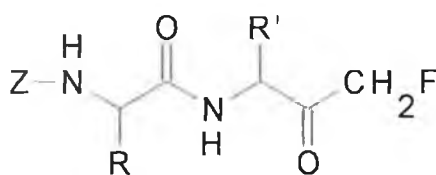

Fig. 2.7 A peptidylfluoromethylketone.

Their mode of action involves the alkylation of the active site nucleophile. The synthesis of these compounds has been described.⁷³⁻⁷⁶

Aza-peptides are also inhibitors of serine proteases^{77,78} and thus may have uses as anti-malarial drugs. Aza-amino acids, whose general structure is shown in fig. 2.8, are amino acids in which the α -carbon has been replaced by a nitrogen atom. They are presumed to act by alkylating the active site nucleophile, forming a stable carbazate.

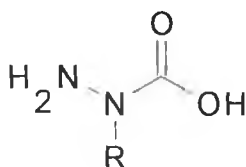

Fig. 2.8 An aza-amino acid.

Considerable specificity can be obtained by altering the side chain of the aza-amino acid residue.^{79,80} Aza-peptides with good leaving groups (eg. *p*-nitrophenolate) are required for inhibition of serine proteases⁸¹ and this necessarily results in a high rate of undesirable side reactions in solution thus reducing the half life of the inhibitor.⁸² More recently it has been shown that the more stable simple alkyl esters of aza-peptides can act as cysteine protease inhibitors due to the increased nucleophilicity of the cysteine thiol.⁸³ The synthesis of aza-peptides has been described.⁸⁴

2.4 Aminopeptidase inhibitors

We have previously seen how the malarial parasite employs a single aminopeptidase in the role of haemoglobin degradation. The goal of this research is the design and synthesis of a compound which would efficiently and selectively inhibit this enzyme. This would provide a suitable starting point for the development of novel anti-malarial drugs.

The aminopeptidases are a group of metal-containing exopeptidases with a specificity for cleavage at the amino terminus of the polypeptide chain. There is much evidence for the catalytic role of the metal ion and inhibitors of these enzymes usually contain functional groups which coordinate to the metal ion. Fournie-Zaluski and co-workers⁸⁵ studied the effect of aminopeptidase N inhibitors. Aminopeptidase N (APN) is a zinc metalloprotease which degrades opiate peptides in the brain. APN removes *N*-terminal hydrophobic acids of substrates preferentially. It also binds with higher affinity to compounds possessing aromatic or highly hydrophobic residues. It appears that there are four essential residues in the active site, one arginine and a carboxylic acid (glutamic or aspartic), as well as a histidine and tyrosine residue.⁸⁶ A large number of amino acid derivatives with zinc-coordinating moieties e.g. SH, COOH, CONHOH, and PO₃H₂, were studied to test their inhibitory effects. The results showed that β -amino thiols were the most efficient APN inhibitors. The general structure of these compounds is shown in fig. 2.9. It is known that simple amino thiols such as L-leucinethiol [fig. 2.10(a)],⁸⁷ L-phenylalaninethiol [fig. 2.10(b)]⁸⁸ and L-lysinethiol [fig. 2.10(c)]⁸⁹ are the most potent inhibitors of aminopeptidases with a thiol-metal ion interaction again responsible for inhibitory potency. A synthetic phenylalanine- β -mercaptoketone⁹⁰ has also been shown to be a potent inhibitor, probably forming a bidentate ligand with the active site zinc via the carbonyl and thiol functionalities (fig. 2.11)

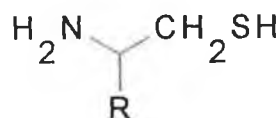
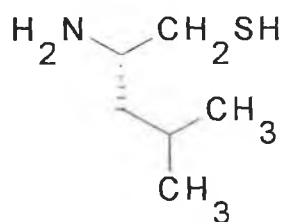
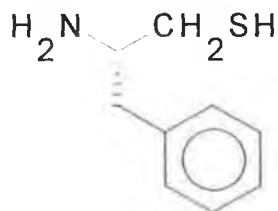

Fig. 2.9 β -Aminothiols.



(a) L-Leucinethiol.



(b) L-Phenylalaninethiol.

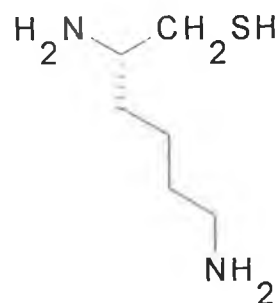

(c) L-Lysinethiol.

Fig. 2.10 Aminothiols.

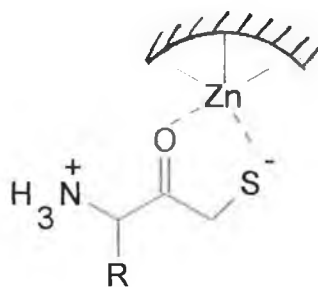

Fig. 2.11 β -Mercaptoketone bound to active site zinc.

Aminophosphonates⁹¹⁻⁹³ are believed to be tetrahedral analogue inhibitors of aminopeptidases. Giannousis and Bartlett⁹⁴ synthesized a variety of phosphorous amino acid and dipeptide analogues and evaluated them as inhibitors of leucine aminopeptidase. Some of these compounds showed modest activity with the most active inhibitors being the phosphonic acid analogues of L-leucine [fig. 2.12(a)] and

L-phenylalanine [fig. 2.12(b)]. Several aminophosphonates were synthesized by Lejczak and co-workers⁹⁵ and tested as inhibitors of leucine and microsomal aminopeptidases in order to observe the effect of structural changes on the activity of the aminophosphonic acids. The most effective inhibitor studied was [1-amino-2-(*N*-cyclohexylamino)ethyl]phosphonic acid [fig. 2.12(c)].

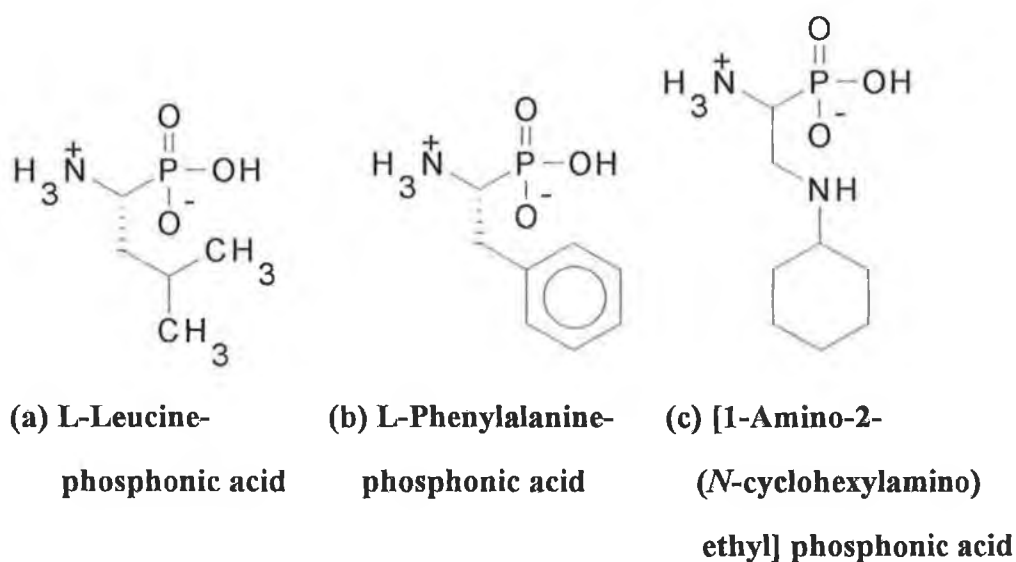

Fig. 2.12 Aminophosphonates.

Hydroxamates of amino acids are also effective inhibitors of aminopeptidases.^{90,96-99} Their mode of action results from the formation of a bidentate ligand with the active site zinc (fig. 2.13).

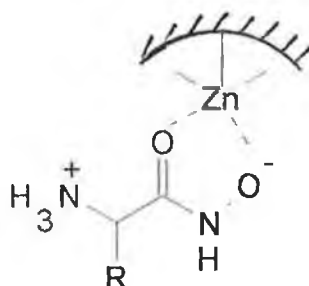

Fig. 2.13 Amino acid hydroxamate bound to active site zinc.

L-leucinal (fig. 2.14) has been shown to be an inhibitor of leucine aminopeptidase¹⁰⁰ and is believed to act as a transition state analogue inhibitor.

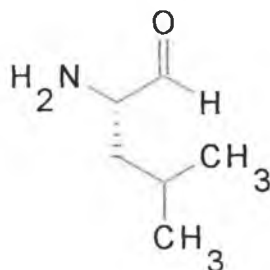
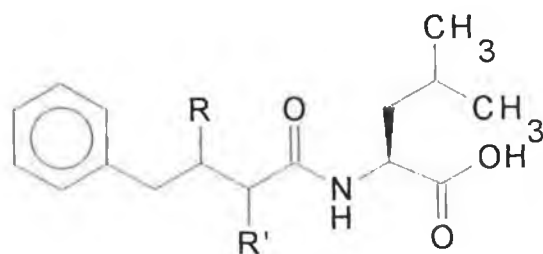

Fig. 2.14 L-leucinal.

Bestatin (fig. 2.15a) is a potent aminopeptidase inhibitor, isolated from species of *actinomyces*¹⁰¹ which has attracted much attention due to its many biological activities. This activity is due to the presence of the novel amino acid 2(S)-hydroxy-3(R)-amino-4-phenylbutanoic acid (AHPB) moiety in its structure.^{102,103} Many methods for the synthesis of AHPB have been described, including, the iodocyclocarbamation of chiral allylamines,¹⁰⁴ the aldol condensation of α -aminoacetophenone with glyoxylic acid,¹⁰⁵ the stereospecific hydroxyamination of an alkene,¹⁰⁶ the chain extension of D-phenylalanine,¹⁰⁷ the opening of an epoxy alcohol with an azide ion,¹⁰⁸ from β -lactams¹⁰⁹ and from the aldol condensation of a chiral glycolate enolate.¹¹⁰ Amastatin (fig.2.16) is a similar aminopeptidase inhibitor.¹¹¹ The synthesis of amastatin via a chain extension of D-leucine has been described in the literature.¹¹² Bestatin and amastatin generally act as slow-binding inhibitors of aminopeptidases¹¹³ and are selective for different aminopeptidases.¹¹⁴



- (a) $R=(3R)\text{-NH}_2$, $R'=(2S)\text{-OH}$ (Bestatin)
- (b) $R=(3R)\text{-NH}_2$, $R'=(2R)\text{-OH}$ (*epi*-Bestatin)
- (c) $R=(3R)\text{-NH}_2$, $R'=(2S)\text{-NH}_2$ (Aminodeoxybestatin)
- (d) $R=(3R)\text{-NH}_2$, $R'=(2R)\text{-NH}_2$ (*epi*-Aminodeoxybestatin)

Fig. 2.15 Bestatin and bestatin analogues.

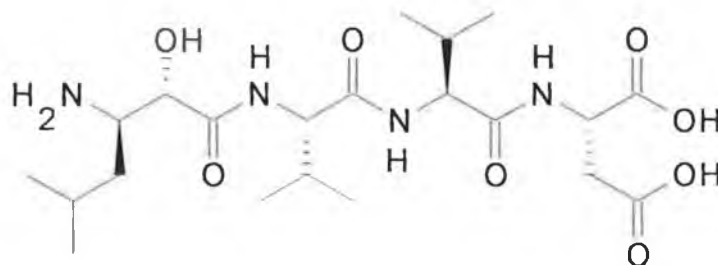

Fig. 2.16 Amastatin.

Structure-modification studies of bestatin, have shown that the presence of the 2(S)-hydroxyl group is necessary for tight binding to aminopeptidases. The structural relationship between bestatins critical 2(S)-hydroxyl group and a probable intermediate for amide bond hydrolysis led to the idea that bestatin may be a transition state analogue inhibitor of aminopeptidases,¹¹⁵ in which the sp_3 geometry of the 2(S)-hydroxyl of the inhibitor mimics the tetrahedral intermediate formed during substrate hydrolysis. Nishizawa *et al*¹¹⁶ proposed that the essential active site zinc is chelated by the 2(S)-hydroxyl group and the 3-amino group when the bestatin is bound to the aminopeptidase (fig2.17(a)). Nishino and Powers¹¹⁷ proposed a

different mechanism in which the 2(S)-hydroxyl and the amide carbonyl bind to the active site zinc (fig 2.17(b)). Both models place the aromatic side chain of the AHPB moiety at P_1 for binding to the S_1 enzyme site. The binding site terminology of Berger and Schechter¹⁴⁸ is used in which the carboxyl side of the scissile bond is termed the P_1 residue and that on the amino side the P_1^* residue with the corresponding subsites to which they bind being labelled S_1 and S_1^* respectively. Many analogues of bestatin have been synthesized in order both to test these hypotheses and to increase activity.

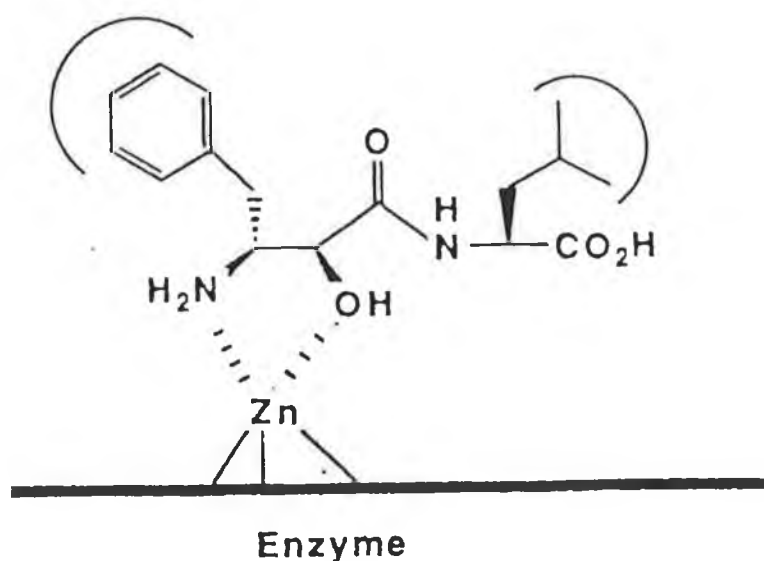

Fig. 2.17(a) Mechanism of binding of bestatin as proposed by Nishisawa *et al.*¹¹⁸

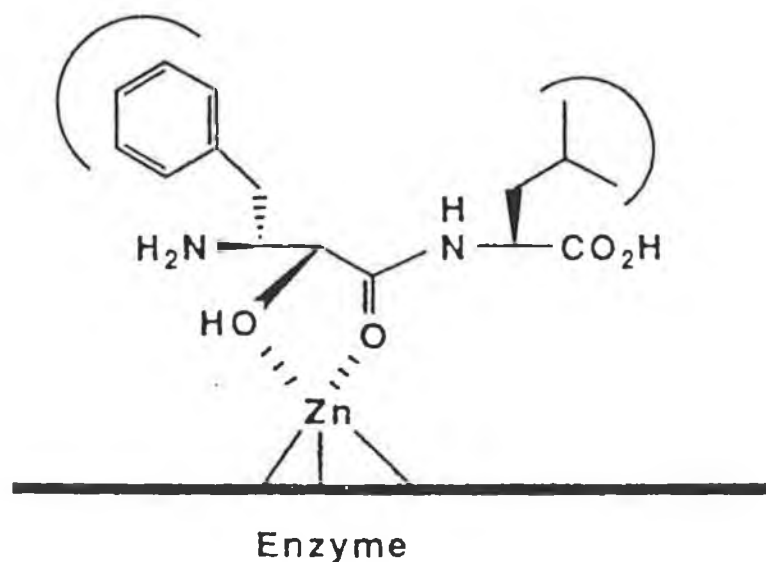

Fig. 2.17(b) Mechanism of binding of bestatin as proposed by Nishino and Powers.¹¹⁸

Nishizawa *et al*¹¹⁶ showed that although a free amino group was necessary for inhibition, the stereochemical configuration at the amino group, was not as important as the configuration at the hydroxyl group. Replacement of the benzyl group with an alkyl or phenyl group resulted in a marked decrease in activity. When the L-leucine residue of bestatin was replaced by other amino acids, only the analogue containing L-isoleucine showed greater activity. *p*-Methyl-, *p*-chloro- and *p*-nitrobestatins showed greater activity than bestatin.

Sulphur replacement analogues of bestatin have been synthesized¹¹⁸ in which the 2(S)-hydroxyl was replaced by a thiol functionality. Since thiols bind well to zinc it was expected that this would increase activity due to the strengthened interaction between this group and the active site zinc. However the inhibitory potency of the thiolbestatin was similar to the corresponding alcohol. This would seem to

suggest that the 2(S)-hydroxyl group of bestatin is not involved in binding to the active site zinc. An alternative mechanism is presented in which the hydroxyl acts as a transition state analogue of the incoming nucleophile i.e. the oxygen of the tetrahedral intermediate which is not bound to the zinc. In this model only the oxygen of the amide carbonyl is bound to the active site zinc. Ocain and Rich¹¹⁹ also synthesized thiol and thioamide analogues of bestatin and found that the thiol analogues showed no significant increase in activity over bestatin. The thioamide analogues were modest inhibitors of aminopeptidases. The expected increase in activity due to the affinity of sulphur for the active site zinc was not observed. By studying leucinethiol derivatives with substituents α to the thiol it was observed that alkyl and carboxyl substituents decreased activity by destabilizing the interaction between the thiol inhibitor and the aminopeptidases. This could account for the absence of the expected increased activity for the thiolbestatin. However it was observed that a carboxamide substituent favoured binding to the enzyme relative to the methyl carboxylate perhaps due to increased stabilizing interactions of the amide proton or the side chain. When viewed together these results seem to suggest that substituents α to the thiol functionality disfavour binding to the active site zinc, but that this may be overcome by increased substituent size as in thiolbestatin.

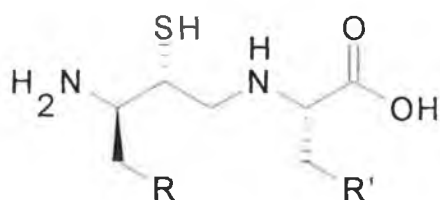

fig. 2.18 - Peptidyl diamino thiol.

The novel peptidyl diamino thiols which were synthesized by Gordon *et al*¹¹⁸ have no carbonyl α to the thiol functionality (fig. 2.18), and show inhibition in the

nanomolar range. Further evidence for the importance of the C₂-hydroxyl group emerges from studies by Herranz and co-workers¹²⁰ who synthesized aminodeoxybestatin (fig. 2.15(c)) and *epi*-aminodeoxybestatin (fig. 2.15(d)). These compounds are bestatin (fig. 2.15(a)) and *epi*-bestatin (fig. 2.15(b)) analogues respectively, in which the hydroxy group has been replaced by an amino functionality. It was observed that the substitution of an amino group for the hydroxyl group resulted in a decrease in inhibitory potency.

CHAPTER THREE

INITIAL STUDIES OF AMINO ACID DERIVATIVES AS INHIBITORS

Introduction

The synthetic strategy employed in this study involved the synthesis of various amino acid and dipeptide derivatives and testing their inhibitory potency in a novel biological assay. Aminopeptidases cleave peptide bonds between amino acids in a peptide chain and thus amino acid and peptide derivatives provide a favourable starting point for the design of novel aminopeptidase inhibitors.

Initially a large number of derivatives with *N*-terminal modifications were synthesized. These derivatives will be discussed in more detail in the relevant sections. These compounds all contained either amide carbonyl or sulphonamide sulphonyl moieties which could form a monodentate ligand with the metal ion at the active site, and would give us an indication of the size and hydrophobicity / hydrophilicity of the active site. The malarial aminopeptidase is known to have an affinity for amino acids with aliphatic hydrophobic side chains²⁰ and so several derivatives of amino acids possessing hydrophobic side chains, as well as derivatives of glycine in which the side chain is simply a hydrogen atom, were synthesized. Derivatives of both the L and D isomers of leucine were prepared in order to observe the effect of the stereochemistry of the α -carbon of the amino acid on the activity of the aminopeptidase. The dipeptide derivatives were synthesized to ascertain whether or not the aminopeptidase had an extended binding site with several sub-sites which could interact with an inhibitor with a longer peptide chain. Further modifications of the *N*-terminal derivatives which showed activity could lead to a very potent inhibitor of the anti-malarial aminopeptidase. To this end it was decided to modify the *C*-terminus of the inhibitors showing the highest activity to increase the potency of the inhibitor. Methyl and ethyl ester, amide and alcohol derivatives of the most potent *N*-terminal modified amino acid inhibitors were prepared and their synthesis will be discussed.

3.1 *N-trans*-Cinnamoyl and related derivatives.

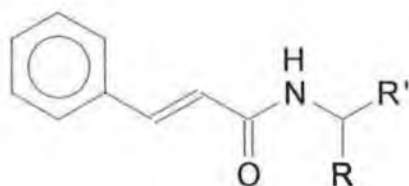

1a - R=H, R'=CO₂H

1b - R=H, R'=CO₂CH₃

1c - R=H, R'=CO₂CH₂CH₃

1d - R=(*S*)-CH₃, R'=CO₂H

1e - R=(*S*)-CH(CH₃)₂, R'=CO₂H

1f - R=(*S*)-CH₂CH(CH₃)₂, R'=CO₂H

1g - R=(*S*)-CH₂CH(CH₃)₂, R'=CO₂CH₃

1h - R=(*S*)-CH₂CH(CH₃)₂, R'=CO₂CH₂CH₃

1i - R=(*S*)-CH₂CH(CH₃)₂, R'=CONH₂

1j - R=(*S*)-CH₂CH(CH₃)₂, R'=CH₂OH

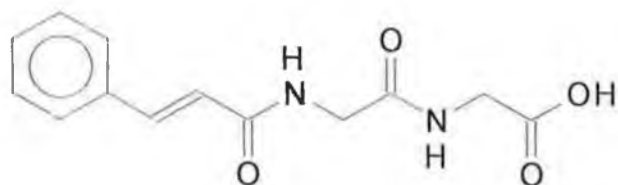

2

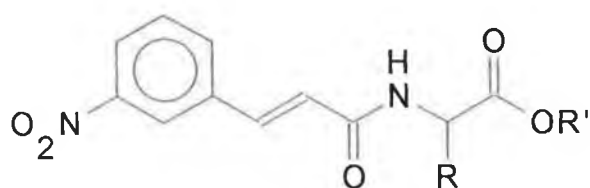

3a - R=H, R'=H

3b - R=H, R'=CH₃

3c - R=H, R'=CH₂CH₃

N-Terminal modifications

N-trans-Cinnamoyl derivatives were synthesized via a *Schotten-Bauman* procedure, by treating the amino acid with cinnamoyl chloride^{121,122} in aqueous alkaline conditions. *N-trans*-Cinnamoyl-amino acids are simple, inexpensive derivatives bearing a degree of structural similarity to bestatin (fig. 2.15a). The phenyl group may interact with the same site in the active site of the aminopeptidase as the phenyl group of bestatin. The presence of the α,β -unsaturated carbonyl system could lead to nucleophilic attack via *Michael* type addition by a nucleophilic centre in the active site (fig 3.1).

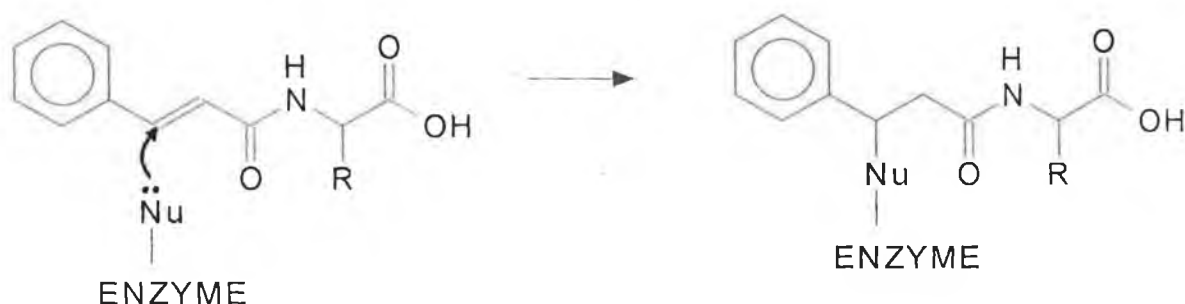

fig. 3.1 Possible *Michael* type addition by nucleophilic centre in the active site of an enzyme.

The *N-trans*-cinnamoyl derivatives of glycine (**1a**), L-alanine (**1d**), L-valine (**1e**), and L-leucine (**1f**) were synthesized to test the affinity of the aminopeptidase for different amino acid side chains. The purification of compound (**1f**) was found to be difficult with the procedure used for the other amino acids. The preparation of (**1f**) by careful base catalyzed hydrolysis of *N-trans*-cinnamoyl-L-leucine methyl ester (**1g**) or ethyl ester (**1h**) gave superior results. Hydrolysis with sodium hydroxide solution^{123,124} was found to be too harsh, resulting in hydrolysis of the amide bond. Satisfactory results were obtained using sodium carbonate solution.¹²⁵ *N-trans*-Cinnamoyl glycylglycine (**2**) was synthesized in order to observe the effect of lengthening the peptide chain on aminopeptidase inhibition.

The i.r. spectra of these compounds all display the characteristic sharp NH peaks superimposed on a broad OH peak in the high frequency region at 3400cm^{-1} , the carboxylic acid C=O peak at 1720cm^{-1} and the amide C=O peak at 1650cm^{-1} . Absorptions in the aromatic region were also noted. The ¹H-n.m.r. spectra contain signals at δ 8.2 which integrate as one proton, due to the amide NH. The signal at δ 7.3-7.6 integrates as six protons and is due to the five phenyl protons and one of the vinylic protons. The signal at δ 6.8 which integrates as one proton are due to the second vinylic proton. The signal for the α -proton of the amino acid residue is seen as a multiplet at δ 4.3. The ¹³C-n.m.r. spectra show characteristic carbonyl signals at δ 165 and δ 172 corresponding to the amide and acid carbonyls respectively. There are six signals in the region δ 120-140 corresponding to four non equivalent aromatic carbons, and the two vinylic carbons.

N-trans-3-Nitrocinnamoyl glycine (**3a**) was synthesized using similar method to that used for the *N-trans*-cinnamoyl derivatives to test the effect of an electron-withdrawing group on the phenyl ring. This would deactivate the aromatic ring, and this may affect its binding to the enzyme. It may also increase the polarization of the amide carbonyl, by withdrawing electron density from the carbonyl carbon. It was found that *trans*-3-nitrocinnamoyl chloride could not be obtained by the treatment of *trans*-3-nitrocinnamic acid with thionyl chloride even with the addition of a catalytic amount of DMF¹²⁶ to form a *Vilsmeier* type reagent¹²⁷ because of the electron withdrawing effect of the nitro group. However treatment of 3-nitrocinnamic acid with PCl₅ in a variation of the method used for the synthesis of 3,5-dinitrobenzoyl chloride¹²¹ furnished the corresponding acid chloride.

The i.r. spectra of these compounds are similar to the i.r. spectra of the *N-trans*-cinnamoyl derivatives except that peaks due to the NO₂ group are observed at 1530 and 1350cm⁻¹. The ¹H-n.m.r. spectra are also similar to the ¹H-n.m.r. spectra of the *N-trans*-cinnamoyl derivatives except for the aromatic region where a separate signal is observed for each phenyl proton and the signals are shifted downfield to δ 7.5-8.2 by the deshielding effect of the NO₂ group. The ¹³C-n.m.r. spectra are again similar to the spectra of the *N-trans*-cinnamoyl derivatives, however the carbon attached to the nitro substituent is shifted to δ 150 due to its deshielding effect.

It should be noted that there is a disparity in the carbon backbone chain lengths between bestatin (fig. 2.14a) and the *N-trans*-cinnamoyl derivatives, of one carbon atom which may affect the interaction between the phenyl group and the active site. To overcome this possible problem, *N*-4-phenylbut-2-enoyl-L-leucine methyl ester (**5**) was also synthesized, to increase the structural similarity to bestatin. 4-phenylbut-2-enoic acid (**4**) could not be obtained by a *Perkin* type reaction procedure but was prepared via a *Doebner* reaction procedure in a variation of the method used for furylacrylic acid.¹²¹ After formation of the acid chloride by treating with thionyl chloride, it was coupled to L-leucine methyl ester (scheme I).

Scheme I

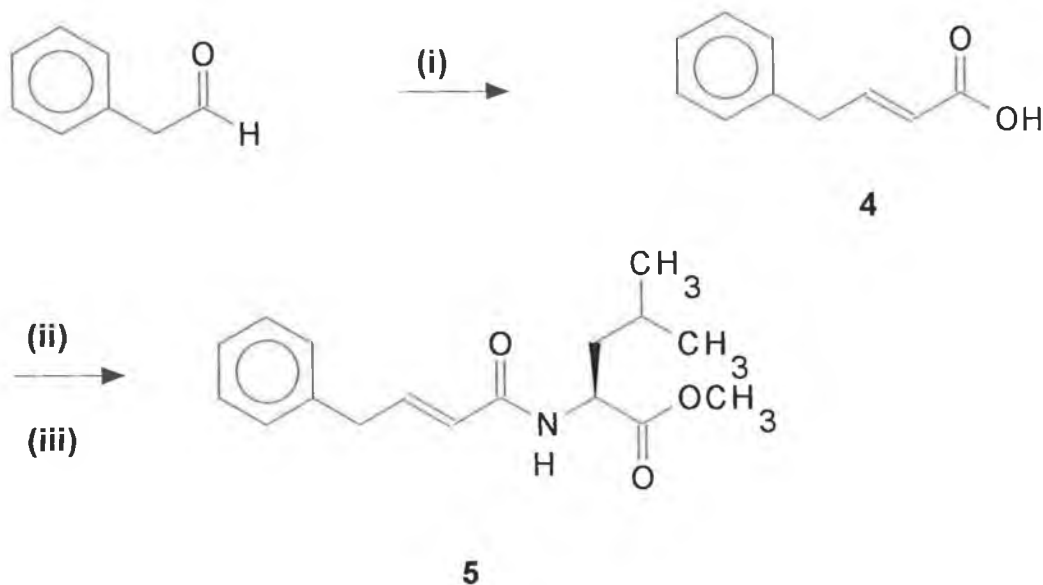

(i) - $\text{H}_2\text{C}(\text{COOH})_2$, $\text{C}_5\text{H}_5\text{N}$

(ii) - SOCl_2 , DCM

(iii) -L-leucine methyl ester hydrochloride, Et_3N , DCM

The i.r spectrum of this compound shows the characteristic NH peak at 3294cm^{-1} , the ester carbonyl peak at 1743cm^{-1} , and an amide carbonyl peak at 1641cm^{-1} . Absorptions in the aromatic region are also observed. The ^1H -n.m.r. spectrum has a multiplet at δ 7.75-7.91 which integrates as five protons due to the aromatic protons. A multiplet at δ 5.2 which integrates as one proton is due to the α -proton. The singlet at δ 4.2 which integrates as three protons is due to the methyl ester protons. The doublet at δ 3.75 integrates as two protons and is due to the benzylic protons. The signals between δ 1.47 and δ 2.19 integrate as nine protons and are due to the protons on the side-chain of the L-leucine residue. The ^{13}C -n.m.r. spectrum is similar to that of *N-trans*-cinnamoyl-L-leucine methyl ester (**1g**), with an extra signal at δ 40 due to the methylene carbon of the benzyl group.

Modifications of the C-terminus

In order to observe the effect of altering the C-terminus of the aminopeptidase inhibitors, *N-trans*-cinnamoyl glycine methyl ester (**1b**), *N-trans*-cinnamoyl glycine ethyl ester (**1c**), *N-trans*-cinnamoyl-L-leucine methyl ester (**1g**), *N-trans*-cinnamoyl-L-leucine ethyl ester (**1h**), *N-trans*-3-nitrocinnamoyl glycine methyl ester (**3b**) and *N-trans*-3-nitrocinnamoyl glycine ethyl ester (**3c**) were synthesized, by either treating the *N-trans*-cinnamoyl derivatives and *N-trans*-3-nitrocinnamoyl derivatives with thionyl chloride and the corresponding alcohol or by treating the amino acid methyl ester hydrochloride with triethylamine and the required carboxylic acid chloride. The i.r. spectra of the esters are similar to the i.r. spectra of the corresponding carboxylic acid derivatives except that as expected the carboxylic acid OH peak is not observed. The ¹H-n.m.r. spectra of the esters are also similar to the ¹H-n.m.r. spectra of the corresponding carboxylic acid derivatives. A singlet at δ 3.4-4.2 which integrates as three protons is due to methyl ester protons and signals at δ 3.6-4.2 and δ 1.2-1.3 which integrate as two and three protons respectively are due to ethyl ester protons. The ¹³C-n.m.r. spectra show an extra signal at δ 52 due to the methyl carbon of the methyl ester group, and those of the ethyl esters show two extra signals at δ 61 and δ 14 corresponding to the methylene and methyl carbons of the ethyl ester group respectively.

N-trans-Cinnamoyl-L-leucinamide (**1i**) was synthesized via an ammonolysis^{121, 123, 124} of *N-trans*-cinnamoyl-L-leucine methyl ester (**1g**). Reduction of *N-trans*-cinnamoyl-L-leucine methyl ester (**1g**) with lithium borohydride¹²⁸ furnished *N-trans*-cinnamoyl-L-leucinol (**1j**).

The i.r. spectrum of *N-trans*-Cinnamoyl-L-leucinamide (**1i**) is similar to the i.r. spectrum of the starting compound (**1f**) except that three NH peaks are observed in the high frequency region at 3400cm⁻¹. The ¹H-n.m.r. spectrum is also similar to that of the starting material except that that no ethyl ester protons are observed. The signal due to the primary amide protons are obscured by the signals for the aromatic protons. The ¹³C-n.m.r. has only five signals due to CH, CH₂ and CH₃ groups, as compared to seven signals in the starting product. This clearly shows the loss of the ethyl ester functionality.

The i.r. spectrum of *N-trans*-cinnamoyl-L-leucinol (**1j**) is again similar to the i.r. spectrum of *N-trans*-cinnamoyl-L-leucine methyl ester (**1g**), except that there is only one

carbonyl peak at 1650cm^{-1} due to the amide carbonyl. A broad peak due to the hydroxyl group is observed in the high frequency region at 3400cm^{-1} . The ^1H -n.m.r. spectra of *N-trans*-cinnamoyl-L-leucinol (**1j**) is also similar to the ^1H -n.m.r. spectra of *N-trans*-cinnamoyl-L-leucine methyl ester (**1g**). However there are two signals at δ 3.6 and δ 3.74 both of which integrate as one proton, due to the two methylene protons adjacent to the hydroxyl group. Only one carbonyl peak is observed in the ^{13}C -n.m.r. spectrum due to the reduction of the ester functionality to an alcohol. The loss of the methyl ester methyl carbon signal at δ 52 is observed as well as an extra signal at δ 66 due to the methylene to which the hydroxyl group is attached.

Attempts to prepare *N-trans*-cinnamoyl-L-leucine hydroxamate, by treating the corresponding ester (**1g**) with hydroxylamine hydrochloride,^{117,129} were unsuccessful. The preparation of *N-trans*-cinnamoyl-L-leucinal by treatment of the corresponding methyl ester (**1g**) with diisobutylaluminium hydride⁵⁴ was not successful. The preparation of *N-trans*-cinnamoyl-L-leucinthiol was also unsuccessful, because the first step in the attempted synthesis i.e. the formation of the *O*-tosylate of *N-trans*-cinnamoyl-L-leucinol (**1j**) did not proceed.

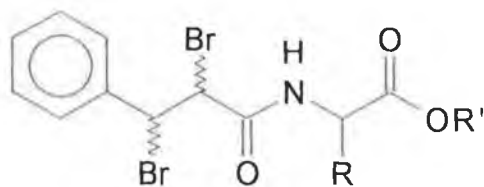

6a - $\text{R}=\text{H}$, $\text{R}'=\text{CH}_2\text{CH}_3$

6b - $\text{R}=(S)\text{-CH}_2\text{CH}(\text{CH}_3)_2$, $\text{R}'=\text{CH}_3$

Modifications of the -C=C- bond

The presence of the -C=C- bond in the *N-trans*-cinnamoyl derivatives opens up the possibility of addition of substituents in the correct positioning for interactions with the active site metal ion of the aminopeptidase. To this end it was desired to brominate, and epoxidise the -C=C- bond to examine the feasibility of this process. Treatment of *N-trans*-cinnamoyl glycine ethyl ester (**1c**) and *N-trans*-cinnamoyl-L-leucine methyl ester (**1g**) with bromine in carbon tetrachloride¹²¹ yielded a mixture of the two enantiomers [(2*S*,3*R*) and 2*R*,3*S*] of *N*-(3-phenyl-2,3-dibromopropionyl)-glycine ethyl ester (**6a**) and *N*-(3-phenyl-2,3-dibromopropionyl)-L-leucine methyl ester (**6b**) respectively. The i.r. spectra of both of these brominated compounds are similar to the corresponding unbrominated vinylic starting compounds. The ¹H-n.m.r. spectra of the brominated compounds are also similar to the ¹H-n.m.r. spectra of the unbrominated starting compounds, except that the signals due to the vinylic protons are replaced by two doublets at δ 5.4 and δ 5.5 both of which integrate as two protons due to the protons on the two brominated carbons. Only four signals are observed in the region δ 120-140 of the ¹³C-n.m.r. spectrum. This is concurrent with the loss of the vinylic carbon signals.

The epoxidation of *N-trans*-cinnamoyl-L-leucine methyl ester (**1g**) was unsuccessful using *m*-CPBA. It has been shown that the rate of epoxidation is increased by the presence of electron-donating substituents on the alkene, and very low reactivity is observed for alkenes with strongly electron-withdrawing substituents.¹³⁰ The presence of the phenyl group conjugated to the -C=C- bond in the cinnamoyl derivatives, as well as the electron-withdrawing effect of the amide carbonyl, may be reducing the electron density around the -C=C- bond thus making electrophilic addition by the peroxy acid less favourable. To overcome this, the epoxidation was also attempted using *t*-butyl hydroperoxide in alkaline conditions, which has a different mechanism involving conjugate nucleophilic addition.¹³¹ This reagent is often used to epoxidise electron-poor alkenes, however in this case the desired product was not formed. The epoxidation of *N*-phenylbut-2-enoyl-L-leucine methyl ester (**5**) with *m*-CPBA was then attempted. In this compound, the phenyl group is not conjugated to the vinylic group, and it was hoped that the epoxidation would proceed more

readily. However in this case the epoxide derivative of 3-phenylbut-2-enoic acid was obtained. Thus the formation of the epoxide causes the hydrolysis of the amide bond.

3.2 N-3,5-Dinitrobenzoyl derivatives

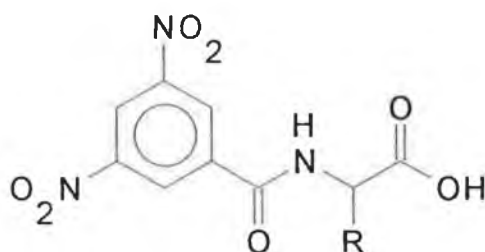

7a R=(*S*)-CH₃

7b R=(*S*)-CH₂CH(CH₃)₂

7c R=(*S*)-CH(CH₃)CH₂CH₃

7d R=(*R*)-CH₂CH(CH₃)₂

N-Terminal modifications

Synthesis of *N*-3,5-dinitrobenzoyl derivatives was achieved by a *Schotten-Baumann* reaction procedure using 3,5-dinitrobenzoyl chloride.¹²¹ It was decided to prepare these compounds for two reasons. Firstly in order to observe whether the phenyl would still interact with the binding site if the distance between it and the amide bond was shortened. More importantly the effect of strongly electron-withdrawing substituents on the phenyl group was investigated. The 3,5-dinitrobenzoyl derivatives of L-alanine (**7a**), L-leucine (**7b**), L-isoleucine (**7c**) and D-leucine (**7d**) were prepared because the aminopeptidase is known to have specificity for amino acids with hydrophobic side chains.

The i.r. spectra of the *N*-3,5-dinitrobenzoyl derivatives all show the characteristic NH peak superimposed on a broad OH peak at 3400cm^{-1} . Peaks at 1720cm^{-1} and 1650cm^{-1} are due to the carboxylic acid and amide carbonyls respectively. Peaks at 1530cm^{-1} and 1350cm^{-1} are characteristic of the NO_2 groups. Absorptions in the aromatic region are also seen. The ^1H -n.m.r. spectra all show a doublet in the region δ 8.4-9.4 which integrates as one proton due to the NH proton. The signals at δ 9.1 and δ 8.9 which integrate as two protons and one proton respectively are due to the aromatic protons. The signal due to the α -proton occurs as a multiplet in the region δ 4.4-4.6. The ^{13}C -n.m.r. spectrum has two carbonyl peaks at δ 162 and δ 174 as well as four aromatic signals in the region δ 120-150. The signal for the aromatic carbon containing the nitro group is shifted downfield to δ 148 due to its deshielding effect.

It was observed from x-ray crystallographic data that *N*-3,5-dinitrobenzoyl-*L*-leucine (**7c**) crystallizes as two separate molecules A and B which differ in conformation about the N1-C2 bond (fig 3.2). The largest angle difference is N1-C2-C4, $115.9(5)^\circ$, $110.0(5)^\circ$ and the torsional angle C1-N1-C2-C3 is $56.1(7)^\circ$ and $-81.5(7)^\circ$ in A,B respectively. Intermolecular hydrogen bonding arises between the amide and carboxylic acid groups as $\text{N-H} \cdots \text{O}=\text{C}$ forming one-dimensional chains and $\text{C}=\text{O} \cdots \text{H}-\text{O}$ forming a two dimensional network by linking neighbouring chains.

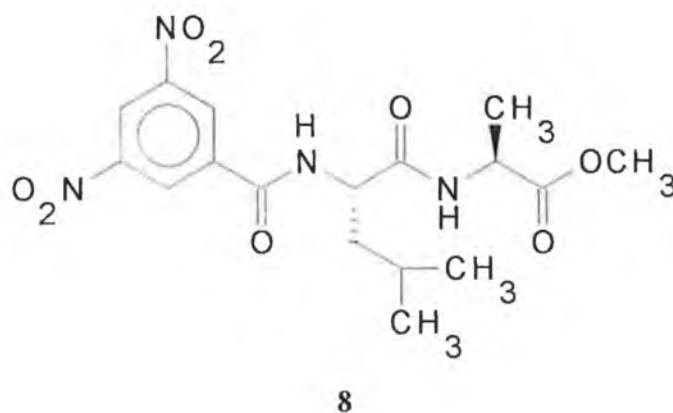

Dipeptide derivatives

To test the effect of increased chain length of the derivative on the activity of the aminopeptidase *N*-3,5-dinitrobenzoyl-L-leucine-L-alanine methyl ester (**8**) was also

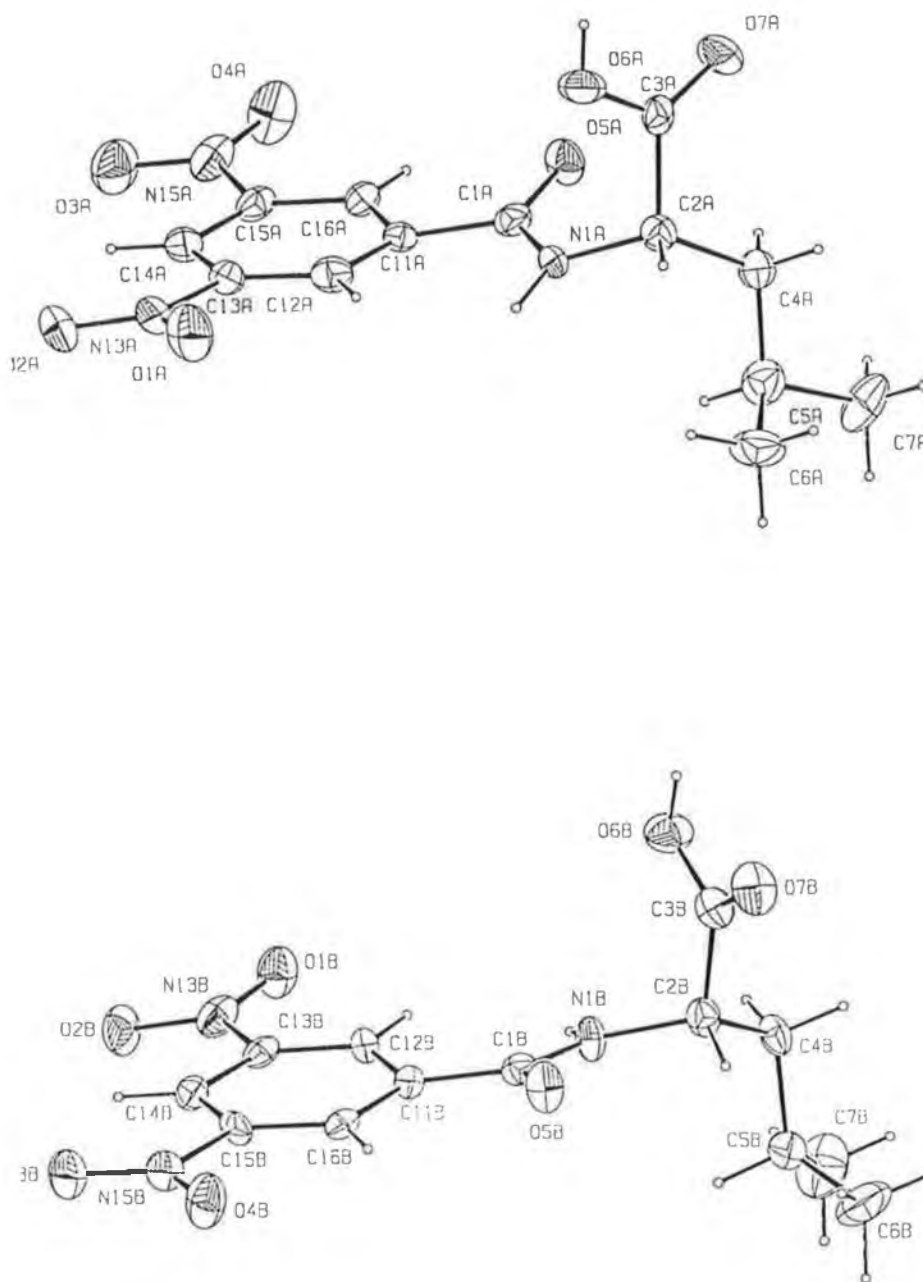
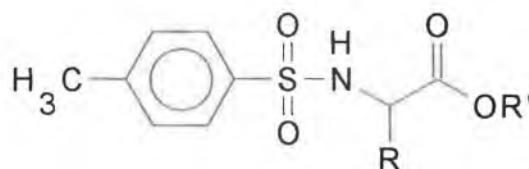

Fig. 3.2 The two conformations of crystalline 3,5-dinitrobenzoyl-L-leucine (7b).

synthesized by coupling *N*-3,5-dinitrobenzoyl-L-leucine and L-alanine methyl ester by treatment with DCCD¹³² and *N*-hydroxybenzotriazole.^{133,134} The i.r spectrum of this compound is similar to the i.r. spectra of the other *N*-3,5-dinitrobenzoyl derivatives described above. The ¹H-n.m.r. spectrum is also similar to the ¹H-n.m.r. spectra of the other *N*-3,5-dinitrobenzoyl derivatives described above. Doublets at δ 8.4 and δ 6.4 which integrate as one proton each, are due to the L-leucyl and L-alanyl NH protons respectively. A singlet at δ 3.6 which integrates as three protons is due to methyl ester protons. The signals at δ 0.88-0.93 and δ 1.57 and δ 1.69 which integrate as six and three protons respectively are due to the L-leucyl side chain. The doublet at δ 1.3 which integrates as three protons is due to the L-alanyl side chain. Three carbonyl signals are observed in the ¹³C-n.m.r. spectrum at δ 162, δ 172, and δ 173.

3.3 *N*-Toluene-*p*-sulphonyl derivatives



9a R=H, R'=H

9b R=(*S*)-CH₃, R'=H

9c R=(*S*)-CH(CH₃)₂, R'=H

9d R=(*S*)-CH₂CH(CH₃)₂, R'=H

9e R=(*S*)-CH(CH₃)CH₂CH₃, R'=H

9f R=(*S*)-CH(CH₃)CH₂CH₃, R'=CH₃

9g R=(*S*)-CH(CH₃)CH₂CH₃, R'=CH₂CH₃

9h R=(*R*)-CH₂CH(CH₃)₂, R'=H

N-Terminal modifications

The synthesis of sulphonamide derivatives was achieved by treating the amino acids with *p*-toluenesulphonyl chloride in aqueous alkaline conditions.¹²¹ The *N*-toluene-*p*-sulphonyl derivatives of glycine (**9a**), L-alanine (**9b**), L-valine (**9c**), L-leucine (**9d**), L-isoleucine (**9e**) and D-leucine (**9h**) were prepared in this manner. In this class of compounds the usual peptide bond is replaced by a sulphonamide functionality which can interact with the active-site metal. The sulphonyl functionality is tetrahedral as compared with the trigonal carbonyl group and this may affect both binding and activity.

The i.r. spectra of the *N*-toluene-*p*-sulphonyl derivatives show characteristic NH peaks at 3300cm⁻¹ and carboxylic acid carbonyl peaks at 1720cm⁻¹. Several peaks are seen in the region 1350-1450cm⁻¹ due to the sulphonamide moiety. Absorptions in the aromatic region are also noted. The ¹H-n.m.r. spectra show a signal at δ 7.9-δ 8.1 which integrates as one proton due to the sulphonamide NH proton. Two doublets at δ 7.6 and δ 7.3, both of which integrate as two protons are due to the aromatic protons. The α-protons give a signal at δ 3.5-3.7. The protons of the toluyl methyl are present as a singlet at δ 2.35 which integrates as three protons. The ¹³C-n.m.r. spectra contain one carbonyl signal at δ 170 and four aromatic carbon peaks in the region δ 125-143. The toluyl methyl carbon gives a signal at δ 21.

C-Terminal derivatives

N-toluene-*p*-sulphonyl-L-isoleucine methyl ester (**9f**) and *N*-*p*-toluenesulphonyl-L-isoleucine ethyl ester (**9g**) were synthesized to observe the effect of the esterification on the potency of derivatives as inhibitors.

The i.r. and ¹H-n.m.r. spectra are similar to the spectra of the *N*-terminal derivatives described above. The methyl ester protons give a singlet at δ 3.3 which integrates as three protons in the ¹H-n.m.r. spectrum while the ethyl ester protons give a quartet and a triplet at δ 3.73 and δ 0.97 which integrate as two and three protons respectively. The ¹³C-n.m.r. spectrum of compound (**9f**) has an extra signal at δ 62 due to the methyl ester carbons, and that of compound (**9g**) has two extra signals at δ 62 and δ 14 due to the ethyl ester carbons.

3.4 3-Nitrophthaloyl derivatives

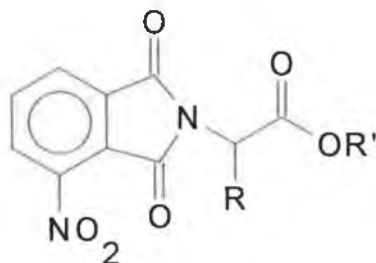

- 10a** R=(*S*)-CH₃, R'=H
10b R=(*S*)-CH₂CH(CH₃)₂, R'=H
10c R=(*S*)-CH₂CH(CH₃)₂, R'=CH₃
10d R=(*S*)-CH₂CH(CH₃)₂, R'=CH₂CH₃
10e R=(*S*)-CH(CH₃)CH₂CH₃, R'=H
10f R=(*S*)-CH(CH₃)CH₂CH₃, R'=CH₃
10g R=(*S*)-CH(CH₃)CH₂CH₃, R'=CH₂CH₃

N-Terminal derivatives

The synthesis of *N*-3-nitrophthalimides was achieved by condensing 3-nitrophthalic anhydride with the appropriate amino acid at high temperatures.¹²¹ The 3-nitrophthaloyl derivatives of L-alanine (**10a**), L-leucine (**10b**) and L-isoleucine (**10e**) were prepared. These compounds are notable in that they do not have a normal peptide bond which the aminopeptidase could cleave. Assuming that the compounds still are recognized by and fit into the enzyme's active site, they may have an inhibitory effect on the enzyme. The presence of the electron-withdrawing nitro group on the phenyl ring could also increase the polarization of the imide carbonyl bonds. This may increase hydrogen bonding interactions in the active site.

The i.r. spectra of the *N*-3-nitrophthaloyl derivatives have a peak at 1720cm^{-1} , due to the carboxylic carbonyl. Characteristic peaks at 1530cm^{-1} and 1350cm^{-1} , are due to the NO_2 group. The ^1H -n.m.r. spectra show three signals between δ 7.9 and δ 8.3 which integrate as three protons due to the aromatic protons. The α -protons give a signal at δ 4.5-4.9. Three peaks are seen in the ^{13}C -n.m.r spectra at δ 170, δ 165 and δ 162, due to the carboxylic acid and phthaloyl carbonyls. Six signals are observed in the region δ 122-145 corresponding to the six non-equivalent aromatic carbons. The aromatic carbon with the nitro substituent is shifted downfield to δ 145.

C-Terminal modifications

Synthesis of methyl and ethyl ester derivatives of the *N*-3-nitrophthaloyl amino acids was achieved by treatment with thionyl chloride and the corresponding alcohol. *N*-3-Nitrophthaloyl-L-leucine methyl ester (**10c**), *N*-3-nitrophthaloyl-L-leucine ethyl ester (**10d**), *N*-3-nitrophthaloyl-L-isoleucine methyl ester (**10f**) and *N*-3-nitrophthaloyl-L-isoleucine (**10g**) were synthesized in this manner. The i.r. and ^1H -n.m.r. spectra of the ester compounds are similar to the *N*-3-nitrophthaloyl amino acid derivatives described above. In the ^1H -n.m.r. spectra, a singlet at δ 1.5 is due to the methyl ester protons, while signals at δ 4.1 and δ 1.2 which integrate as two and three protons are due to the ethyl ester protons. The ^{13}C -n.m.r spectra are similar to the parent compounds with the extra signals for the methyl and ethyl ester carbons occurring at δ 55 for the methyl ester carbons and δ 62 and δ 14 for the ethyl ester carbons.

3.5 N-Phenylureido derivatives

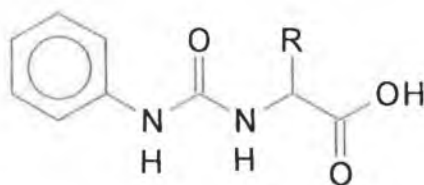

11a R=(*S*)-CH₃

11b R=(*S*)-CH₂CH(CH₃)₂

11c R=(*S*)-CH(CH₃)CH₂CH₃

N-Terminal modifications

The synthesis of *N*-phenylureido amino acids was achieved by treating the amino acids with phenyl isocyanate in alkaline aqueous solution.¹²¹ *N*-Phenylureido-L-alanine (**11a**), *N*-phenylureido-L-leucine (**11b**), and *N*-phenylureido-L-isoleucine (**11c**) were furnished in this manner. Again these compounds are unusual in that they possess a urea functionality rather than a normal peptide bond which could affect recognition and binding at the active site.

The i.r. spectra of these compounds show two NH peaks at 3400cm⁻¹ and 3350cm⁻¹. The carboxylic acid carbonyl gives a peak at 1720cm⁻¹ and an amide carbonyl peak appears at 1650cm⁻¹. Absorptions in the aromatic region are also observed. The ¹H-n.m.r. gives two NH signals which appear at δ 8.5 and δ 6.4. Three peaks between δ 6.9 and δ 7.4 which integrate as five protons are due to the aromatic protons. The ¹³C-n.m.r. spectra shows a carboxylic acid carbonyl signal at δ 175 and a peak due to the urea carbonyl at δ 155 which is shifted upfield because of the shielding effect of the two NH substituents.

3.6 N-Chloroacetyl derivatives

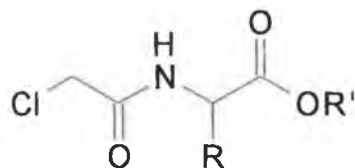

12a R=H, R'=H

12b R=(*S*)-CH₂CH(CH₃)₂, R'=H

12c R=(*S*)-CH₂CH(CH₃)₂, R'=CH₃

12d R=(*S*)-CH₂CH(CH₃)₂, R'=CH₂CH₃

12e R=(*R*)-CH₂CH(CH₃)₂, R'=H

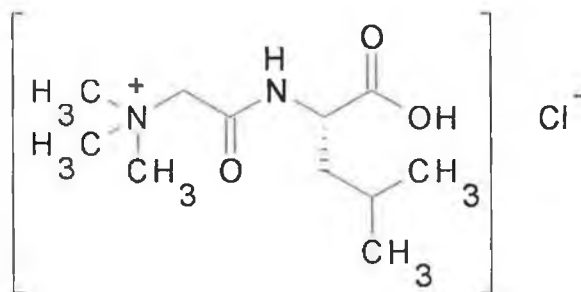

13

N-Terminal modifications

N-Chloroacetyl amino acid derivatives were synthesized by a direct method of acetylation in the absence of any added base, by refluxing the amino acid with chloroacetyl chloride in anhydrous ethyl acetate.^{135,136} This method of acetylation furnished *N*-chloroacetyl glycine (**12a**), *N*-chloroacetyl-L-leucine (**12b**) and *N*-chloroacetyl-D-leucine

(12e). The presence of the alkyl halide bond could lead to nucleophilic displacement by a nucleophilic group present in the active site. Also the compounds may be further derivatised by nucleophilic displacement with functional groups to chelate the active site metal ion.

The i.r spectra of the *N*-chloroacetyl amino acid derivatives show characteristic peaks at 3400cm^{-1} due to the NH group, at 1720cm^{-1} due to the carboxylic acid carbonyl, and at 1650cm^{-1} due to the amide carbonyl. A singlet at δ 4.0 which integrates as two protons in the ^1H -n.m.r. spectra is due to the chloroacetyl methylene protons. The ^{13}C -n.m.r. spectra show two carbonyl signals at δ 171 and δ 166 which correspond to the carboxylic acid and chloroacetyl carbonyls respectively. A peak observed at δ 42 is due to the chloroacetyl methylene carbons.

N-Trimethylammoniumacetyl-L-leucine chloride (**13**), was synthesized by treating *N*-chloroacetyl-L-leucine (**12b**) with a solution of trimethylamine¹³⁷ in order to observe the effect of a charged group incorporated into the inhibitor on aminopeptidase activity.

The ^1H -n.m.r. spectrum has a signal at δ 3.33 which integrates as nine protons due to the trimethylammonium protons. The CH_2 of the acetyl group gives a singlet at δ 4.18, which integrates as two protons. A signal at δ 64 in the ^{13}C -n.m.r. spectrum is due to the trimethylammonium methyl carbons.

C-terminal modifications

N-Chloroacetyl-L-leucine methyl ester (**12c**) and *N*-chloroacetyl-L-leucine ethyl ester (**12d**), were synthesized by treating *N*-chloroacetyl-L-leucine (**12b**), with thionyl chloride and methanol or ethanol respectively. The i.r and ^1H -n.m.r. spectra are similar to that of *N*-chloroacetyl-L-leucine (**12b**), described above. The ^1H -n.m.r. spectrum of the methyl ester has a singlet at δ 3.68 which integrates as three protons due to the methyl ester protons while that of the ethyl ester has a quartet at δ 4.09 and a triplet at δ 1.18 which integrate as two and three protons respectively due to the ethyl ester protons. The ^{13}C -n.m.r. spectra show characteristic signals at δ 52 for the methyl ester carbons and at δ 61 and δ 14 for the ethyl ester carbons.

3.7 Experimental

Experimental note

All melting point determinations were carried out on a Griffin melting point apparatus and are uncorrected. All infra-red spectra were recorded on either a Nicolet 205 FTIR or a Perkin Elmer System 2000 FTIR spectrometer. ¹H-n.m.r spectra were recorded on a Brüker AC 400 spectrometer, operating at 400MHz in Aldrich deuterated solvents with tetramethylsilane as an internal standard. ¹³C-n.m.r spectra were also recorded on a Brüker AC 400 spectrometer, operating at 100MHz in Aldrich deuterated solvents with tetramethylsilane as an internal standard. Electron impact mass spectra were recorded on a VG 7070E mass spectrometer (electron energy=70ev, source temperature=200°C, resolution=10,000). Fast atom bombardment mass spectra were run on a Jeol SX 102 mass spectrometer (resolution=5,000) with thioglycerol or nitrobenzyl alcohol as the matrix. Riedel-de Haën silica gel 60 F254 TLC plates and Riedel-de Haën silica gel S were used for thin layer and column / flash chromatography respectively. The t.l.c. plates were examined with u.v. illumination at λ 254nm, by staining with iodine or vanillin or by spraying with ninhydrin solution. All chemicals were purchased from the Sigma/Aldrich Company. Amino acid ester hydrochlorides were prepared by the method of Brenner¹³⁸ by treating the amino acid with thionyl chloride and the corresponding alcohol.

N-trans-Cinnamoyl glycine (1a)

trans-Cinnamoyl chloride (6.7g, 0.04mol) in diethyl ether (50ml) was added cautiously to a solution of glycine (1.5g, 0.02mol) in 10% sodium hydrogen carbonate (30ml). The resulting solution was stirred at room temperature for 4hr. The solution was acidified with 10% hydrochloric acid and the resulting precipitate filtered. Recrystallisation of the solid from ethanol/water gave *N-trans*-cinnamoyl glycine as fine white needles (1.4g, 34.2%).

m.p. 190-192°C (uncorrected). Lit 197°C (193-4°C).^{136,139}

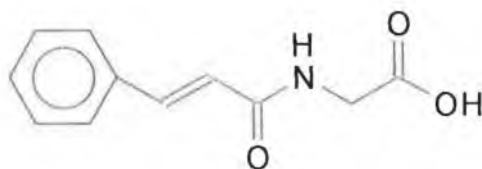

Spectroscopic analysis

i.r ν_{\max} (KBr): 3300 (NH), 1740 (carboxylic acid C=O), 1650 (amide C=O), 1600, 1200 cm^{-1} .

¹H-n.m.r.(400MHz) δ (DMSO): 3.9 (2H, d, J=5.9Hz -NHCH₂CO₂H), 6.7 (1H, d, J=15.8Hz PhCH=CHCO-), 7.37-7.47 (4H, m, PhCH=CHCO- and ArH 3,4&5), 7.6 (2H, d, J=6.4Hz, ArH 2&6), 8.45 (1H, t, J=5.9Hz -NH).

¹³C-n.m.r.(100MHz) δ (DMSO):171.41 (-NHCH₂CO₂H), 163.34 (PhC=CHCO-), 139.26, 134.82, 129.61, 128.50, 127.63, 121.68 (aromatic and vinylic carbons), 40.87 (-NHCH₂CO₂H).

N-trans-Cinnamoyl glycine methyl ester (1b)

Thionyl chloride (1.2g, 0.01mol) was added dropwise to methanol (20ml) at 0°C. *N-trans*-cinnamoyl glycine (2g, 0.01mol) was added in portions and the temperature was slowly increased to 40°C. The reaction mixture was stirred at 40°C for 4hr and the excess methanol removed *in vacuo*. The resulting white solid was washed with 5% sodium hydrogen carbonate, water and dried. The white solid crystallised from ethyl acetate/petroleum ether (40-60°C) furnishing *N-trans*-cinnamoyl glycine methyl ester¹⁴⁰ as fine white needles (1.23g, 56.1%).

m.p. 60-62°C (uncorrected).

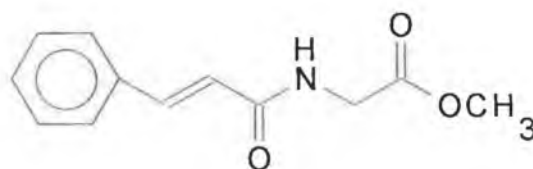

Spectroscopic analysis

i.r. ν_{\max} (KBr): 3325 (NH), 1750 (ester C=O), 1650 (amide C=O), 1600, 1550, 1200 cm^{-1}

$^1\text{H-n.m.r.}$ (400MHz) δ (DMSO): 3.37 (3H, s, -NHCH₂CO₂CH₃), 3.9 (2H, d, J=6Hz, -NHCH₂CO₂CH₃), 6.7 (1H, d, J=15.8Hz, PhCH=CHCO-), 7.4-7.48 (4H, m, PhCH=CHCO- and ArH 3,4&5), 7.6 (2H, d, J=6.4Hz, ArH 2&6), 8.58 (1H, t, J=6Hz, -NH).

$^{13}\text{C-n.m.r.}$ (100MHz) δ (DMSO): 170.46 (-NHCH₂CO₂CH₃), 165.46 (PhCH=CHCO-), 139.48, 134.73, 129.66, 128.50, 127.66, 121.40 (aromatic and vinylic carbons), 51.78 (-NHCH₂CO₂CH₃), 40.80 (-NHCH₂CO₂CH₃).

N-trans-Cinnamoyl glycine ethyl ester (1c)

N-trans-Cinnamoyl glycine ethyl ester was synthesized by the procedure used for the synthesis of *N-trans*-cinnamoyl glycine methyl ester. Thionyl chloride (1.2g, 0.01mol), was added to ethanol (20ml) at 0°C. *N-trans*-cinnamoyl glycine (2g, 0.01mol.) was added in portions. Recrystallisation from ethyl acetate/petroleum ether 40-60 yielded *N-trans*-cinnamoyl glycine ethyl ester as fine white needles (890mg, 38.2%).

m.p. 102-104°C (uncorrected). Lit 108°C.¹³⁹

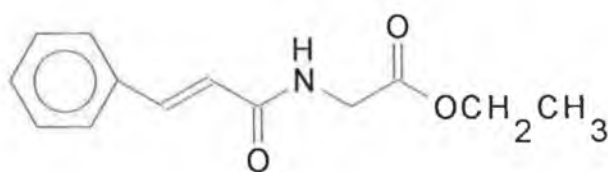

Spectroscopic analysis

i.r ν_{\max} (KBr): 3400 (NH), 1725 (ester C=O), 1675 (amide C=O), 1625, 1525, 1200 cm^{-1} .

¹H-n.m.r.(400MHz) δ (DMSO): 1.2 (3H, t, J=6.9Hz, -NHCH₂CO₂CH₂CH₃), 3.95 (2H, d, J=5.9Hz, -N(H)CH₂CO₂CH₂CH₃), 4.1 (2H, q, J=6.9Hz, NHCH₂CO₂CH₂CH₃), 6.7 (1H, d, J=15.7Hz, PhCH=CHCO-), 7.39-7.47 (4H, m, PhCH=CHCO and ArH 3,4&5), 7.6 (2H, d, J=6.4Hz, ArH 2&6), 8.55 (1H, t, J=5.9Hz, -NH).

¹³C-n.m.r.(100MHz) δ (DMSO): 169.95 (-NHCH₂CO₂CH₂CH₃), 165.43 (PhCH=CHCO-), 139.44, 134.73, 129.64, 128.50, 127.66, 121.42 (aromatic and vinylic carbons), 60.50 (-NHCH₂CO₂CH₂CH₃), 40.89 (-NHCH₂CO₂CH₂CH₃), 14.11 (-NHCH₂CO₂CH₂CH₃).

N-trans-Cinnamoyl-L-alanine (1d)

trans-Cinnamoyl chloride (6.7g, 0.04mol) in diethyl ether (50ml) was added to a solution of L-alanine (1.8g, 0.02mol) in 1M sodium hydroxide (40ml). The reaction mixture was stirred for 4hr at room temperature and the ether removed *in vacuo*. The reaction mixture was acidified with 10% hydrochloric acid and the precipitate filtered. Purification using column chromatography on silica gel [chloroform-ethyl acetate (1:1) to which a small amount of acetic acid was added] yielded *N-trans*-cinnamoyl-L-alanine (1.16g, 26.4%) as a white solid. m.p. 184-186°C (uncorrected). Lit 191°C.¹³⁶

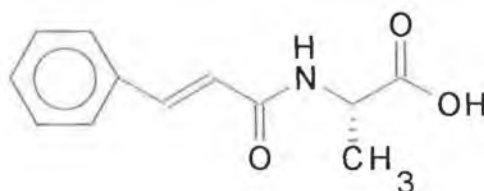

Spectroscopic analysis

i.r. ν_{\max} (KBr): 3400 (NH), 1725 (carboxylic acid C=O), 1650 (amide C=O), 1550, 1200 cm^{-1} .

¹H-n.m.r.(400MHz) δ (DMSO): 1.32 (3H, d, J=7Hz, -NHCH(CH₃)CO₂H), 4.32-4.33 (1H, m, -NHCH(CH₃)CO₂H), 6.71 (1H, d, J=16.2Hz, PhCH=CHCO-), 7.37-7.46 (4H, m, PhCH=CHCO- and ArH 3,4&5), 7.56 (2H, d, J=6.4Hz, ArH 2&6) 8.43 (1H, d, J=7Hz, -NH).

¹³C-n.m.r.(100MHz) δ (DMSO): 173.68 (-NHCH(CH₃)CO₂H), 164.14 (PhCH=CHCO-), 138.61, 134.31, 128.46, 127.03, 121.22 (aromatic and vinylic carbons), 47.14 (-NHCH(CH₃)CO₂H), 16.81 (-NHCH(CH₃)CO₂H).

N-trans-Cinnamoyl-L-valine (1e)

The synthesis of *N-trans*-cinnamoyl-L-valine was achieved using the procedure described for *N-trans*-cinnamoyl-L-alanine. *trans*-Cinnamoyl chloride (6.7g, 0.04mol) in diethyl ether (50ml) was added to a solution of L-valine (2.34g, 0.02mol) in 1M sodium hydroxide (40ml). Purification by column chromatography on silica gel [chloroform-ethyl acetate (1:1) to which a small amount of acetic acid was added] furnished *N-trans*-cinnamoyl-L-valine as a white solid (845mg, 17.1%)

m.p. 176-178°C (uncorrected). Lit 188°C.¹³⁶

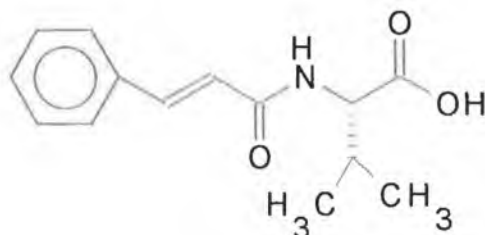

Spectroscopic analysis

i.r ν_{\max} (KBr): 3350 (NH), 1700 (carboxylic acid C=O), 1650 (amide C=O), 1550, 1200 cm^{-1} .

¹H-n.m.r.(400MHz) δ (DMSO): 0.92 (6H, d, J=6Hz, -NHCH(CH(CH₃)₂)CO₂H), 2.1 (1H, m, -NHCH(CH(CH₃)₂)CO₂H), 4.29 (1H, dd, J_A=8.4Hz, J_B=6Hz, -NHCH(CH(CH₃)₂)CO₂H), 6.87 (1H, d, J=15.8Hz, PhCH=CHCO-), 7.36-7.46 (4H, m, PhCH=CHCO- and ArH 3,4&5), 7.57 (2H, d, J=6.4Hz, ArH, 2&6), 8.23 (1H, d, J=8.4Hz, -NH).

^{13}C -n.m.r.(100MHz) δ (DMSO): 173.09 (-NHCH(CH(CH₃)₂)CO₂H), 163.14 (PhCH=CHCO-), 139.14, 134.93, 129.51, 128.97, 127.53, 121.91 (aromatic and vinylic carbons), 57.30 (-NHCH(CH(CH₃)₂)CO₂H), 29.95 (-NHCH(CH(CH₃)₂)CO₂H), 19.20, 18.01 (-NHCH(CH(CH₃)₂)CO₂H).

N-trans-Cinnamoyl-L-leucine (1f)

Potassium carbonate solution (1M, 20ml) was added slowly to a solution of *N-trans*-cinnamoyl-L-leucine methyl ester (**1g**) (2.75, 0.01mol) in methanol (20ml). The resulting solution was stirred at room temperature for 48hr, acidified with hydrochloric acid (1M) and the methanol removed *in vacuo*. After cooling the precipitate was filtered and dried. Purification of the product by flash chromatography [petroleum ether 40-60/ethyl acetate (6:4)] yielded the title compound¹⁴¹ as a waxy solid (1.74g, 67%).

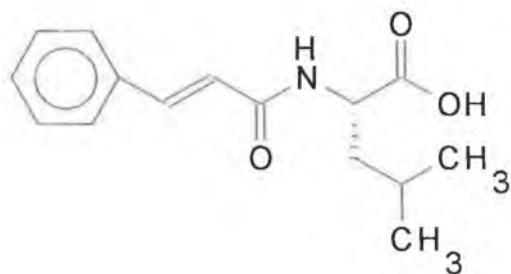

Spectroscopic analysis

i.r ν_{max} (CHCl₃): 3312 (OH), 1714 (carboxylic acid C=O), 1663 (amide C=O), 1620, 1542, 1353, 1216, 975cm⁻¹.

^1H -n.m.r.(400MHz) δ (CDCl₃): 0.92 (6H, d, J=5.9Hz, -NHCH(CH₂CH(CH₃)₂)CO₂H), 1.61-1.77 (3H, m, -NHCH(CH₂CH(CH₃)₂)CO₂H and -NHCH(CH₂CH(CH₃)₂)CO₂H), 4.71-4.77 (1H, m, -NHCH(CH₂CH(CH₃)₂)CO₂H), 6.46 (1H, d, J=15.7Hz, PhCH=CHCO-), 6.58 (1H, d, J=8Hz, NH), 7.24-7.44 (5H, m, ArH), 7.60 (1H, d, J=15.7Hz, PhCH=CHCO-).

^{13}C -n.m.r.(100MHz) δ (CDCl_3): 176.46 (-NHCH(CH₂CH(CH₃)₂)CO₂H), 166.75 (PhCH=CHCO-), 142.36, 134.42, 129.87, 128.73, 127.94, 119.58 (aromatic and vinylic carbons), 51.23 (-NHCH(CH₂CH(CH₃)₂)CO₂H), 41.07 (-NHCH(CH₂CH(CH₃)₂)CO₂H), 24.88 (-NHCH(CH₂CH(CH₃)₂)CO₂H), 22.81, 21.77 (-NHCH(CH₂CH(CH₃)₂)CO₂H).

N-trans-Cinnamoyl-L-leucine methyl ester (1g)

A solution of *trans*-cinnamoyl chloride (3.35g, 0.02mol) in chloroform (50ml) was added dropwise to a solution of L-leucine methyl ester hydrochloride (1.8g, 0.01mol) and triethylamine (1.4ml, 0.01mol) in chloroform (50ml) at 0°C. After 30min the reaction temperature was increased to room temperature and the reaction allowed to proceed for 6hr. The solution was then washed with 10% sodium hydrogen carbonate solution, water and dried. The solvent was removed *in vacuo* and recrystallization of the resulting oil from ethyl acetate/pet ether yielded the title product¹⁴¹ as a white crystalline solid (1.15g, 42%).

m.p. 70-72°C (uncorrected). Lit. 80-82°C.¹⁴²

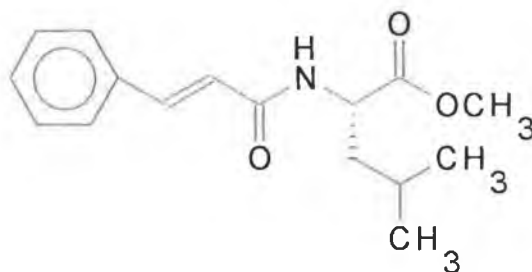

Spectroscopic analysis

i.r. ν_{max} (KBr): 3257 (NH), 3075, 2951, 2879, 1736 (ester C=O), 1663 (amide C=O), 1620, 1554, 1445, 1343, 1205, 1154 cm^{-1} .

$^1\text{H-n.m.r.}(400\text{MHz})\delta(\text{CDCl}_3)$: 0.97 (6H, m, $-\text{NHCH}(\text{CH}_2\text{CH}(\text{CH}_3)_2)\text{CO}_2\text{CH}_3$), 1.58-1.73 (3H, m, $-\text{NHCH}(\text{CH}_2\text{CH}(\text{CH}_3)_2)\text{CO}_2\text{CH}_3$ and $-\text{NHCH}(\text{CH}_2\text{CH}(\text{CH}_3)_2)\text{CO}_2\text{CH}_3$), 3.76 (3H, s, $-\text{NHCH}(\text{CH}_2\text{CH}(\text{CH}_3)_2)\text{CO}_2\text{CH}_3$), 4.80 (1H, m, $-\text{NHCH}(\text{CH}_2\text{CH}(\text{CH}_3)_2)\text{CO}_2\text{CH}_3$), 6.29 (1H, d, $J=8.4\text{Hz}$, $-\text{NH}$), 6.45 (1H, d, $J=15.8\text{Hz}$, $\text{PhCH}=\text{CHCO}-$), 7.32-7.36 (3H, m, ArH 2,4&6), 7.45-7.48 (2H, m, ArH 3&5), 7.62 (1H, d, $J=15.8\text{Hz}$, $\text{PhCH}=\text{CHCO}-$).

$^{13}\text{C-n.m.r.}(100\text{MHz})\delta(\text{CDCl}_3)$: 173.80 ($-\text{NHCH}(\text{CH}_2\text{CH}(\text{CH}_3)_2)\text{CO}_2\text{CH}_3$), 165.58 ($\text{PhCH}=\text{CHCO}-$), 141.71, 134.63, 129.71, 128.73, 127.81, 119.99 (aromatic and vinylic carbons), 52.31 ($-\text{NHCH}(\text{CH}_2\text{CH}(\text{CH}_3)_2)\text{CO}_2\text{CH}_3$), 50.80 ($-\text{NHCH}(\text{CH}_2\text{CH}(\text{CH}_3)_2)\text{CO}_2\text{CH}_3$), 41.78 ($-\text{NHCH}(\text{CH}_2\text{CH}(\text{CH}_3)_2)\text{CO}_2\text{CH}_3$), 24.86 ($-\text{NHCH}(\text{CH}_2\text{CH}(\text{CH}_3)_2)\text{CO}_2\text{CH}_3$), 22.79, 21.95 ($-\text{NHCH}(\text{CH}_2\text{CH}(\text{CH}_3)_2)\text{CO}_2\text{CH}_3$).

N-trans-Cinnamoyl-L-leucine ethyl ester (1h)

N-trans-Cinnamoyl-L-leucine ethyl ester was synthesized using the same method as outlined for *N-trans*-cinnamoyl-L-leucine methyl ester. A solution of *trans*-cinnamoyl chloride (3.35g, 0.02mol) in chloroform (50ml) was added dropwise to a solution of L-leucine ethyl ester hydrochloride (1.95g, 0.01mol) and triethylamine (1.4ml, 0.01mol) in chloroform (50ml) at 0°C . Recrystallization from ethyl acetate/pet ether yielded *N-trans*-cinnamoyl-L-leucine ethyl ester as a white crystalline solid (1.05g, 38%).

m.p. $88-90^\circ\text{C}$ (uncorrected).

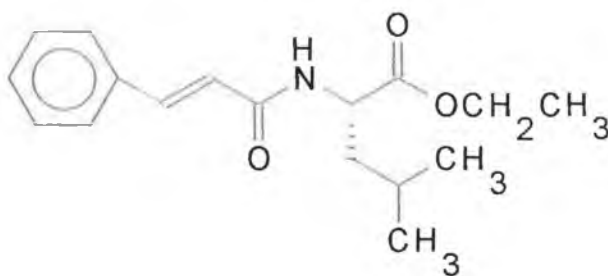

Spectroscopic analysis

i.r. ν_{\max} (KBr): 3274, 2968, 1744 (ester C=O), 1629 (amide C=O), 1558, 1452, 1353, 1203, 1152, 1082 cm^{-1} .

^1H -n.m.r.(400MHz) δ (CDCl_3): 0.95-0.99 (6H, d, $J=5.9\text{Hz}$, $-\text{NHCH}(\text{CH}_2\text{CH}(\text{CH}_3)_2\text{CO}_2\text{CH}_2\text{CH}_3)$), 1.3 (3H, t, $J=7.1\text{Hz}$, $-\text{NHCH}(\text{CH}_2\text{CH}(\text{CH}_3)_2\text{CO}_2\text{CH}_2\text{CH}_3)$), 1.58-1.75 (3H, m, $-\text{NHCH}(\text{CH}_2\text{CH}(\text{CH}_3)_2\text{CO}_2\text{CH}_2\text{CH}_3)$ and $-\text{NHCH}(\text{CH}_2\text{CH}(\text{CH}_3)_2\text{CO}_2\text{CH}_2\text{CH}_3)$), 4.2 (2H, q, $J=7.2\text{Hz}$, $-\text{NHCH}(\text{CH}_2\text{CH}(\text{CH}_3)_2\text{CO}_2\text{CH}_2\text{CH}_3)$), 4.77-4.83 (1H, m, $-\text{NHCH}(\text{CH}_2\text{CH}(\text{CH}_3)_2\text{CO}_2\text{CH}_2\text{CH}_3)$), 6.36 (1H, d, $J=8.4\text{Hz}$, $-\text{NH}$), 6.45 (1H, d, $J=15.7\text{Hz}$, $\text{PhCH}=\text{CHCO}-$), 7.26-7.48 (5H, m, ArH), 7.62 (1H, d, $J=15.7\text{Hz}$, $\text{PhCH}=\text{CHCO}-$).

^{13}C -n.m.r.(100MHz) δ (CDCl_3): 173.46 ($-\text{NHCH}(\text{CH}_2\text{CH}(\text{CH}_3)_2\text{CO}_2\text{CH}_2\text{CH}_3)$), 165.60 ($\text{PhCH}=\text{CHCO}-$), 141.64, 134.64, 129.69, 128.72, 127.81, 120.04 (aromatic and vinylic carbons), 61.43 ($-\text{NHCH}(\text{CH}_2\text{CH}(\text{CH}_3)_2\text{CO}_2\text{CH}_2\text{CH}_3)$), 50.86 ($-\text{NHCH}(\text{CH}_2\text{CH}(\text{CH}_3)_2\text{CO}_2\text{CH}_2\text{CH}_3)$), 41.85 ($-\text{NHCH}(\text{CH}_2\text{CH}(\text{CH}_3)_2\text{CO}_2\text{CH}_2\text{CH}_3)$), 24.87, ($-\text{NHCH}(\text{CH}_2\text{CH}(\text{CH}_3)_2\text{CO}_2\text{CH}_2\text{CH}_3)$), 22.81, 21.96 ($-\text{NHCH}(\text{CH}_2\text{CH}(\text{CH}_3)_2\text{CO}_2\text{CH}_2\text{CH}_3)$), 14.12 ($-\text{NHCH}(\text{CH}_2\text{CH}(\text{CH}_3)_2\text{CO}_2\text{CH}_2\text{CH}_3)$).

N-trans-Cinnamoyl-L-leucinamide (1i)

A vigorous stream of ammonia gas was introduced to a solution of *N-trans*-cinnamoyl-L-leucine methyl ester (2.75g, 0.01mol) in methanol (75ml) at 0°C. After 1hr the introduction of ammonia was discontinued, the reaction vessel sealed and allowed to warm to room temperature. The reaction was left to stand for 12hr and the solvent removed *in vacuo*. The resulting dry residue was triturated with ethyl acetate, filtered, washed with ethyl acetate and dried to yield *N-trans*-cinnamoyl-L-leucinamide as a white solid (1.87g, 72%).

m.p. 178-180°C (uncorrected).

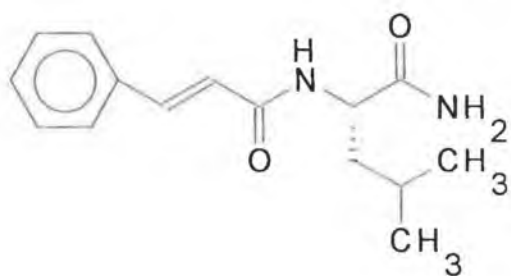

Spectroscopic analysis

i.r. ν_{\max} (KBr): 3388, 3295, 3189 (NH and NH₂), 3189, 2968, 1651 (amide C=O), 1609, 1545, 1452, 1346, 1217cm⁻¹.

¹H-n.m.r.(400MHz)δ(DMSO): 0.85-0.90 (6H, d, J=6.4Hz, -NHCH(CH₂CH(CH₃)₂)CO NH₂), 1.47-1.51 (2H, m, -NHCH(CH₂CH(CH₃)₂)CONH₂), 1.56-1.64 (1H, m, -NHCH(CH₂CH(CH₃)₂)CONH₂), 4.36-4.42 (1H, m, -NHCH(CH₂CH(CH₃)₂)CONH₂), 6.75 (1H, d, J=15.7Hz, PhCH=CHCO-), 7.33-7.55 (8H, m, ArH, PhCH=CHCO- and -NH₂), 8.16 (1H, d, J=8.4Hz, -NH).

^{13}C -n.m.r.(100MHz) δ (DMSO): 174.17, 164.68 (PhCH=CHCO- and -NHCH(CH₂CH(CH₃)₂CONH₂), 138.74, 134.95, 129.39, 128.91, 127.46, 122.25 (aromatic and vinylic carbons), 50.90 (-NHCH(CH₂CH(CH₃)₂CONH₂), 41.24 (-NHCH(CH₂CH(CH₃)₂CONH₂), 24.36, (-NHCH(CH₂CH(CH₃)₂CONH₂), 23.02, 21.60 (-NHCH(CH₂CH(CH₃)₂CONH₂).

Mass spectrum: $[\text{M}+\text{H}]^+$ found: 261.1046 C₁₅H₂₁N₂O₂ requires 261.16016

N-trans-Cinnamoyl -L-leucinol (1j)

Lithium chloride (1.83g, 0.04mol) and sodium borohydride (1.64g, 0.04mol), were added to a solution of *N-trans*-cinnamoyl-L-leucine methyl ester (2.75g, 0.01mol) in tetrahydrofuran (50ml) and ethanol (50ml) at 0°C. The reaction was allowed to proceed under nitrogen at room temperature for 18hr and then quenched with 1M HCl. The reaction mixture was extracted with ethyl acetate and the organic fraction washed with water, HCl (1M), NaHCO₃ (1M) and brine. After drying the solvent was removed under reduced pressure. Recrystallization of the residue from ethyl acetate/pet ether yielded the title product as fine white crystals (1.93g, 73%). m.p. 110-114°C (uncorrected). Lit. 115-116°C.¹⁴³

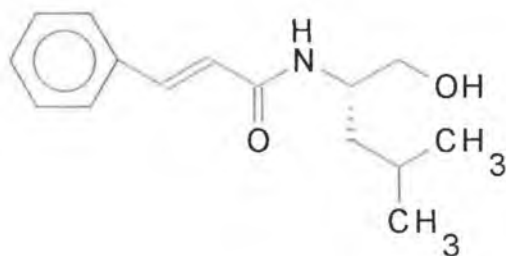

Spectroscopic analysis

i.r. ν_{\max} (KBr): 3466, 3301 (OH), 2960, 1659 (amide C=O), 1630, 1552, 1346, 1210, 1068 cm^{-1} .

^1H -n.m.r.(400MHz) δ (CDCl_3): 0.94 (6H, d, $J=6.9\text{Hz}$, $-\text{NHCH}(\text{CH}_2\text{CH}(\text{CH}_3)_2)\text{CH}_2\text{OH}$), 1.36-1.51 (2H, m, $-\text{NHCH}(\text{CH}_2\text{CH}(\text{CH}_3)_2)\text{CH}_2\text{OH}$), 1.63-1.73 (1H, m, $-\text{NHCH}(\text{CH}_2\text{CH}(\text{CH}_3)_2)\text{CH}_2\text{OH}$), 3.58-3.62 (1H, dd, $J_A=11\text{Hz}$, $J_B=3.5\text{Hz}$, $-\text{NHCH}(\text{CH}_2\text{CH}(\text{CH}_3)_2)\text{CH}_2\text{OH}$), 3.72-3.76 (1H, dd, $J_A=11\text{Hz}$, $J_B=3.5\text{Hz}$, $-\text{NHCH}(\text{CH}_2\text{CH}(\text{CH}_3)_2)\text{CH}_2\text{OH}$), 4.17-4.22 (1H, m, $-\text{NHCH}(\text{CH}_2\text{CH}(\text{CH}_3)_2)\text{CH}_2\text{OH}$), 6.15 (1H, d, $J=8.4\text{Hz}$, $-\text{NH}$), 6.44 (1H, d, $J=15.8\text{Hz}$, $\text{PhCH}=\text{CHCO}-$), 7.30-7.33 (3H, m, ArH 3,4&5), 7.44-7.47 (2H, m, ArH 2&6). 7.61 (1H, d, $J=15.8\text{Hz}$, $\text{PhCH}=\text{CHCO}-$).

^{13}C -n.m.r.(100MHz) δ (CDCl_3): 166.71 ($\text{PhCH}=\text{CHCO}-$), 141.38, 134.67, 129.69, 128.75, 127.78, 120.51 (aromatic and vinylic carbons), 66.11 ($-\text{NHCH}(\text{CH}_2\text{CH}(\text{CH}_3)_2)\text{CH}_2\text{OH}$), 50.24 ($-\text{NHCH}(\text{CH}_2\text{CH}(\text{CH}_3)_2)\text{CH}_2\text{OH}$), 40.33 ($-\text{NHCH}(\text{CH}_2\text{CH}(\text{CH}_3)_2)\text{CH}_2\text{OH}$), 24.93, ($-\text{NHCH}(\text{CH}_2\text{CH}(\text{CH}_3)_2)\text{CH}_2\text{OH}$), 23.02, 22.18 ($-\text{NHCH}(\text{CH}_2\text{CH}(\text{CH}_3)_2)\text{CH}_2\text{OH}$).

Attempted preparation of *N-trans*-cinnamoyl-L-leucine hydroxamate

Triethylamine (2ml, 0.014mol) was added to a stirring solution of hydroxylamine hydrochloride (1g, 0.014mol) in DMF (10ml) and the precipitated triethylamine hydrochloride filtered. The filtrate was added to a solution of *N-trans*-cinnamoyl-L-leucine ethyl ester (4g, 0.014mol) in DMF (20ml) and stirred gently at room temperature for 5 days. The DMF was evaporated under reduced pressure to yield a red solid. Recrystallization from ethyl acetate/petroleum ether did not yield the desired product and the reaction was not investigated further.

Attempted preparation of *N*-(phenyl-2,3-epoxypropionyl)-L-leucine methyl ester

m-CPBA (3.45g, 0.02mol) was added to solution of *N-trans*-cinnamoyl-L-leucine methyl ester (2.75g, 0.01mol) in dichloromethane (50ml) at 0°C. The reaction was stirred at room temperature for 40hr, washed with 2.5% sodium hydrogen carbonate solution, water and dried. The solvent was removed by evaporation. Recrystallization from ethyl acetate/petroleum ether yielded only the starting material and the reaction was not investigated further.

Attempted preparation of *N*-cinnamoyl-L-leucinol-*O*-tosylate

Toluene-*p*-sulphonyl chloride (3.81g, 0.02mol) in dry pyridine (25ml) was added to *N*-cinnamoyl-L-leucinol (2.47g, 0.01mol) in dry pyridine (25ml) at 0°C. The reaction mixture was warmed to room temperature and stirred at this temperature for 24hr. Dichloromethane (100ml) was then added and the reaction mixture washed with cold hydrochloric acid (1M, 3x25ml), sodium bicarbonate solution (10%, 2x25ml) and water (3x25ml). The organic fraction was dried and the solvent evaporated. Attempted purification of the resultant oil by flash chromatography did not yield the desired product and the reaction was not investigated further.

***N-trans*-Cinnamoyl glycylglycine (2)**

trans-Cinnamoyl chloride (6.7g, 0.04mol), in diethyl ether (50ml) was added cautiously to a solution of glycylglycine (2.64g, 0.02mol) in sodium hydrogen carbonate (10%, 50ml). The solution was stirred at room temperature for 4hr, acidified with 10% hydrochloric acid and the precipitate filtered. Recrystallisation of the solid from ethanol/water furnished *N-trans*-cinnamoyl glycylglycine as very fine white needles (1.4g, 26.5%).
m.p. 212-216°C (uncorrected).

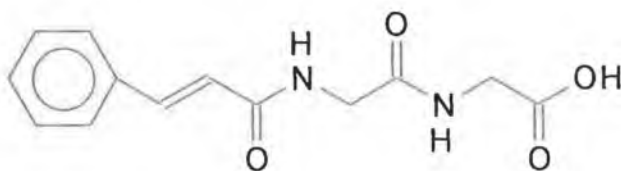

i.r. ν_{\max} (KBr): 3350 , 3300 (OH), 1720 (carboxylic acid C=O), 1650 (amide C=O), 1600, 1550, 1200 cm^{-1} .

^1H -n.m.r.(400MHz) δ (DMSO): 3.77 (2H, d, $J=5.9\text{Hz}$, $-\text{NHCH}_2\text{CONHCH}_2\text{CO}_2\text{H}$), 3.87 (2H, d, $J=5.9\text{Hz}$, $-\text{NHCH}_2\text{CONHCH}_2\text{CO}_2\text{H}$), 6.74 (1H, d, $J=15.8\text{Hz}$, $\text{PhCH}=\text{CHCO}-$), 7.38-7.46 (4H, m, $\text{PhCH}=\text{CHCO}-$, ArH 3,4&5), 7.57 (2H, d, $J=6.4\text{Hz}$, ArH 2&6), 8.26 (1H, t, $J=5.9\text{Hz}$, $-\text{NHCH}_2\text{CONHCH}_2\text{CO}_2\text{H}$), 8.41 (1H, t, $J=5.9\text{Hz}$, $\text{NHCH}_2\text{CONHCH}_2\text{CO}_2\text{H}$).

Note: The peaks at 3.77 and 3.87 may be interchangeable. The peaks at 8.26 and 8.41 may also be interchangeable.

^{13}C -n.m.r.(100MHz) δ (DMSO): 172.34, ($-\text{NHCH}_2\text{CONHCH}_2\text{CO}_2\text{H}$), 165.25, 163.12 ($\text{PhCH}=\text{CHCO}-$ and $-\text{NHCH}_2\text{CONHCH}_2\text{CO}_2\text{H}$), 139.02, 134.88, 129.58, 129.02, 127.60, 121.96 (aromatic and vinylic carbons), 41.96, 40.65 ($-\text{NHCH}_2\text{CONHCH}_2\text{CO}_2\text{H}$ and $-\text{NHCH}_2\text{CONHCH}_2\text{CO}_2\text{H}$).

Note: The signals at 165.25 and 163.12 may be interchangeable. The signals at 41.96 and 40.65 may also be interchangeable.

Mass spectrum: $[\text{M}+\text{H}]^+$ found: 263.0610 $\text{C}_{13}\text{H}_{15}\text{N}_2\text{O}_4$ requires 263.10304

N-trans-3-Nitrocinnamoyl glycine (3a)

Finely powdered *trans*-3-nitrocinnamoyl chloride (8.46g, 0.04mol) was added cautiously to a solution of glycine (1.5g, 0.02mol) in 10% sodium hydrogen carbonate (30ml). The reaction mixture was stirred vigorously for 4hr at room temperature, acidified with 10% hydrochloric acid and the precipitate filtered. Recrystallisation of the solid from ethanol/water afforded *N-trans*-3-nitrocinnamoyl glycine as an off-white precipitate (980mg, 19.6%).

m.p. 168-170°C (uncorrected).

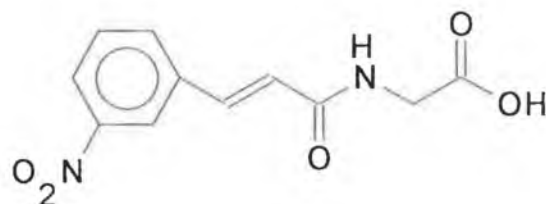

Spectroscopic analysis

i.r ν_{\max} (KBr): 3500 (OH), 3400 (NH), 1725 (carboxylic acid C=O), 1650 (amide C=O), 1600, 1525, 1350, 1225 cm^{-1} .

$^1\text{H-n.m.r.}$ (400MHz) δ (DMSO): 3.90 (2H, d, $J=5.9\text{Hz}$, $-\text{NHCH}_2\text{CO}_2\text{H}$), 6.92 (1H, d, $J=15.7\text{Hz}$, $\text{O}_2\text{NPhCH}=\text{CHCO}-$), 7.57 (1H, d, $J=15.8\text{Hz}$, $\text{O}_2\text{NPhCH}=\text{CHCO}-$), 7.70 (1H, t, $J=7\text{Hz}$, ArH 5), 8.02 (1H, d, $J=7\text{Hz}$, ArH 6), 8.20 (1H, d, $J=7\text{Hz}$ ArH 4), 8.4 (1H, s, ArH 2), 8.47 (1H, t, $J=5.4\text{Hz}$, $-\text{NH}$).

^{13}C -n.m.r.(100MHz) δ (DMSO): 171.18 (-NHCH $\underline{\text{C}}$ O $\underline{\text{C}}$ H), 164.72 (O $\underline{\text{C}}$ NP $\underline{\text{C}}$ H=CH $\underline{\text{C}}$ O-), 148.30, 136.91, 136.69, 133.89, 130.49, 124.54, 123.81, 121.70 (aromatic and vinylic carbons), 41.50 (-NHCH $\underline{\text{C}}$ O $\underline{\text{C}}$ H).

N-trans-3-Nitrocinnamoyl glycine methyl ester (3b)

N-trans-3-Nitrocinnamoyl glycine methyl ester was synthesized by the method described for *N-trans*-cinnamoyl glycine methyl ester. Thionyl chloride (1.2g, 0.01mol) was added dropwise to methanol (20ml) at 0°C. *N-trans*-3-nitrocinnamoyl glycine (2.5g, 0.01mol), was added in portions. Purification by column chromatography yielded *N-trans*-3-nitrocinnamoyl glycine methyl ester (1.22g, 46.2%). m.p 154-156°C (uncorrected).

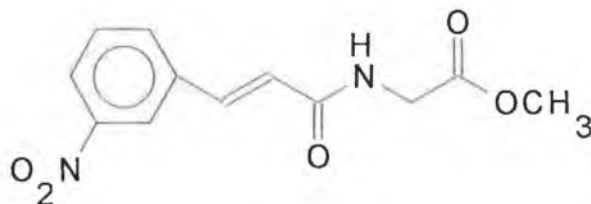

Spectroscopic analysis

i.r. ν_{max} (KBr): 3371 (NH), 1727 (ester C=O), 1674 (amide C=O), 1636, 1537, 1348, 1211 cm^{-1} .

^1H -n.m.r.(400MHz) δ (CDCl $_3$): 3.81 (3H, s, -NHCH $\underline{\text{C}}$ O $\underline{\text{C}}$ H $\underline{\text{C}}$ H $_3$), 4.22 (2H, d, J=5.4Hz, -NHCH $\underline{\text{C}}$ O $\underline{\text{C}}$ H $\underline{\text{C}}$ H $_3$), 6.3 (1H, bs, -NH), 6.61 (1H, d, J=15.8Hz, O $\underline{\text{C}}$ NP $\underline{\text{C}}$ H=CH $\underline{\text{C}}$ O-), 7.57 (1H, t, J=7Hz, ArH 5), 7.71 (1H, d, J=15.7Hz, O $\underline{\text{C}}$ NP $\underline{\text{C}}$ H=CH $\underline{\text{C}}$ O-), 7.8 (1H, d, J=7Hz, ArH 6), 8.20 (1H, m, ArH 4), 8.38 (1H, s, ArH 2).

^{13}C -n.m.r.(100MHz) $\delta(\text{CDCl}_3)$: 170.27 (-NHCH₂CO₂CH₃), 164.85 (O₂NPhCH=CHCO-), 148.60, 139.30, 136.36, 133.87, 129.93, 124.18, 122.71, 121.93 (aromatic and vinylic carbons), 52.57 (-NHCH₂CO₂CH₃), 41.52 (-NHCH₂CO₂CH₃).

Mass spectrum: $[\text{M}+\text{H}]^+$ found: 265.0658 C₁₂H₁₃N₂O₅ requires 265.0823

N-trans-3-Nitrocinnamoyl glycine ethyl ester (3c)

N-trans-3-Nitrocinnamoyl glycine ethyl ester was furnished by the method outlined for *N-trans*-cinnamoyl glycine ethyl ester. Thionyl chloride (1.2g, 0.01mol) was added to ethanol (20ml) at 0°C. *N-trans*-3-Nitrocinnamoyl glycine (2.5g, 0.01mol.) was added portionwise. Purification by column chromatography yielded *N-trans*-3-nitrocinnamoyl glycine ethyl ester (1.15g, 41.4%)

m.p. 120-124°C (uncorrected).

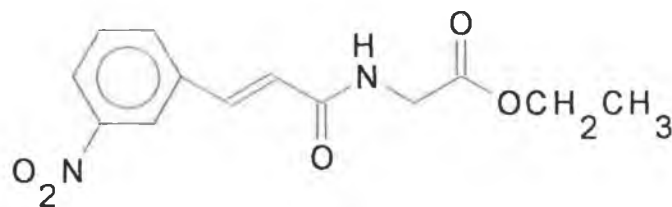

Spectroscopic analysis

i.r. $\nu_{\text{max}}(\text{KBr})$: 3356 (NH), 3311, 1727 (ester C=O), 1674 (amide C=O), 1621, 1537, 1348, 1211cm⁻¹.

$^1\text{H-n.m.r.}(400\text{MHz})\delta(\text{CDCl}_3)$: 1.31 (3H, t, $J=7\text{Hz}$, $-\text{NHCH}_2\text{CO}_2\text{CH}_2\text{CH}_3$), 4.20 (2H, d, $J=4.9\text{Hz}$, $-\text{NHCH}_2\text{CO}_2\text{CH}_2\text{CH}_3$), 4.26 (2H, q, $J=7\text{Hz}$, $-\text{NHCH}_2\text{CO}_2\text{CH}_2\text{CH}_3$), 6.4 (1H, bs, $-\text{NH}$), 6.63 (1H, d, $J=15.8\text{Hz}$, $\text{O}_2\text{NPhCH}=\text{CHCO}-$), 7.57 (1H, t, $J=7\text{Hz}$, ArH 5), 7.70 (1H, d, $J=15.7\text{Hz}$, $\text{O}_2\text{NPhCH}=\text{CHCO}-$), 7.8 (1H, d, $J=7\text{Hz}$, ArH 6), 8.20 (1H, d, $J=7\text{Hz}$, ArH 4), 8.38 (1H, s, ArH 2).

$^{13}\text{C-n.m.r.}(100\text{MHz})\delta(\text{CDCl}_3)$: 169.85 ($-\text{NHCH}_2\text{CO}_2\text{CH}_2\text{CH}_3$), 164.85 ($\text{O}_2\text{NPhCH}=\text{CHCO}-$), 148.60, 139.17, 136.37, 133.86, 129.91, 124.14, 122.79, 121.91 (aromatic and vinylic carbons), 61.77 ($-\text{NHCH}_2\text{CO}_2\text{CH}_2\text{CH}_3$), 41.66 ($-\text{NHCH}_2\text{CO}_2\text{CH}_2\text{CH}_3$), 14.13 ($-\text{NHCH}_2\text{CO}_2\text{CH}_2\text{CH}_3$).

Mass spectrum: $[\text{M}+\text{H}]^+$ found 279.0565 $\text{C}_{13}\text{H}_{15}\text{N}_2\text{O}_5$ requires 279.09749, $[\text{M}+\text{Na}]$ found 300.9804 $\text{C}_{13}\text{H}_{14}\text{N}_2\text{O}_5\text{Na}$ requires 301.07944

***N-trans*-(4-Phenylbut-2-enoyl)-L-leucine methyl ester (5)**

Thionyl chloride (1ml, 0.01mol) was added to a solution of 4-phenylbut-2-enoic acid. (2g, 0.01mol) in dichloromethane (20ml). The mixture was heated under reflux for 1hr, allowed to cool and the dichloromethane and unreacted thionyl chloride removed *in vacuo*. The resulting brown oil was dissolved in chloroform (20ml) and added dropwise to a solution of L-leucine methyl ester hydrochloride (1.8g, 0.01mol) and triethylamine (1ml, 0.01mol) at 0°C . The reaction mixture was stirred at room temperature for 4hr, washed with 10% sodium hydrogen carbonate (2x20ml), water and dried. Purification by column chromatography on silica gel [ethyl acetate:pet ether (1:1)] furnished the title compound as a yellow oil.

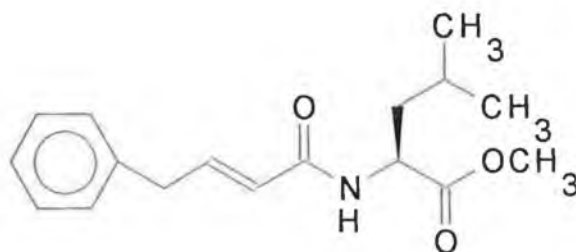

Spectroscopic analysis

i.r. ν_{\max} (CHCl₃): 3294 (NH), 2959, 1743 (ester C=O), 1641 (amide C=O), 1532, 1437, 1365, 1205, 1169cm⁻¹.

¹H-n.m.r.(400MHz) δ (CDCl₃): 1.47 (6H, d, J=6Hz, -NHCH(CH₂CH(CH₃)₂)CO₂CH₃), 2.06-2.19 (3H, m, -NHCH(CH₂CH(CH₃)₂)CO₂CH₃ and -NHCH(CH₂CH(CH₃)₂)CO₂CH₃), 3.73 (2H, d, J=7.4Hz, PhCH₂CH=CHCO-), 4.25 (3H, s, -NHCH(CH₂CH(CH₃)₂)CO₂CH₃), 5.20 (1H, m, -NHCH(CH₂CH(CH₃)₂)CO₂CH₃), 6.80-6.88 (1H, m, PhCH₂CH=CHCO-), 6.95 (1H, d, J=7.9Hz NH), 7.07 (1H, d, J=15.8Hz, PhCH₂CH=CHCO-), 7.75-7.91 (5H, m, ArH).

¹³C-n.m.r.(100MHz) δ (CDCl₃): 173.47 (-NHCH(CH₂CH(CH₃)₂)CO₂CH₃), 170.70 PhCH₂CH=CHCO-, 136.53, 134.32, 128.40, 127.40, 126.13, 121.90 (aromatic and vinylic carbons), 52.13 (-NHCH(CH₂CH(CH₃)₂)CO₂CH₃), 50.65 (-NHCH(CH₂CH(CH₃)₂)CO₂CH₃), 41.26, 40.24 (-NHCH(CH₂CH(CH₃)₂)CO₂CH₃ and PhCH₂CH=CHCO-), 24.73, (-NHCH(CH₂CH(CH₃)₂)CO₂CH₃), 22.62, 21.79 (-NHCH(CH₂CH(CH₃)₂)CO₂CH₃).

Note: The signals at 41.26 and 40.24 may be interchangeable.

Mass spectrum: [M+H]⁺ found: 290.0768 C₁₇H₂₄NO₃ requires 290.17545

Attempted preparation of *N*-(4-phenyl-2,3-epoxybutanoyl)-L-leucine methyl ester

m-CPBA (3.45g, 0.02mol) was added to solution of *N*-*trans*-cinnamoyl-L-leucine methyl ester (2.75g, 0.01mol) in dichloromethane (50ml) at 0°C. The reaction was stirred at room temperature for 40hr, washed with 2.5% sodium hydrogen carbonate solution, water and dried. The solvent was removed by evaporation. Recrystallization from ethyl acetate/petroleum ether did not afford the expected product and the reaction was not investigated further.

N-(3-Phenyl-2,3-dibromopropionyl)-glycine ethyl ester (6a)

A solution of bromine in carbon tetrachloride (20ml) was added dropwise at 0°C to a stirring suspension of *N*-*trans*-cinnamoyl glycine ethyl ester (1.1g, 0.005mol) in carbon tetrachloride. The temperature of the reaction was slowly raised to 40°C and stirred at this temperature for a further 4hr. The excess solvent and unreacted bromine were removed *in vacuo* and the resulting oil was recrystallized from ethanol/water to furnish a mixture of isomers of the title compound as a white crystalline solid (412mg, 28.9%). m.p. 122-124°C (uncorrected).

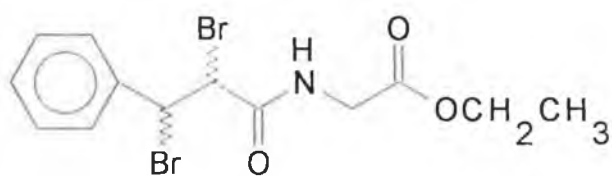

Spectroscopic analysis

i.r. ν_{\max} (KBr): 3309 (NH), 1763 (ester C=O), 1667 (amide C=O), 1578, 1377, 1214 cm^{-1} .

^1H -n.m.r.(400MHz) δ (DMSO): 1.2 (6H, t, $J=7\text{Hz}$, $-\text{NHCH}_2\text{CO}_2\text{CH}_2\text{CH}_3$), 3.99 (4H, d, $J=5.9\text{Hz}$, $-\text{NHCH}_2\text{CO}_2\text{CH}_2\text{CH}_3$), 4.09-4.14 (4H, q, $J=7\text{Hz}$, $-\text{NHCH}_2\text{CO}_2\text{CH}_2\text{CH}_3$), 5.36 (2H, d, $J=11.8\text{Hz}$, $\text{PhCH}(\text{Br})\text{CH}(\text{Br})\text{CO}-$), 5.52 (2H, d, $J=11.8\text{Hz}$, $\text{PhCH}(\text{Br})\text{CH}(\text{Br})\text{CO}-$), 7.33-7.51 (10H, m, ArH), 8.94 (2H, t, $J=5.9\text{Hz}$, $-\text{NH}$).

^{13}C -n.m.r.(100MHz) δ (DMSO): 169.18, 167.13 ($-\text{NHCH}_2\text{CO}_2\text{CH}_2\text{CH}_3$ and $\text{PhCH}(\text{Br})\text{CH}(\text{Br})\text{CO}-$), 138.80, 129.03, 128.83, 128.08 (aromatic protons), 60.64 ($-\text{NHCH}_2\text{CO}_2\text{CH}_2\text{CH}_3$), 51.44, 48.23 ($\text{PhCH}(\text{Br})\text{CH}(\text{Br})\text{CO}-$ and $\text{PhCH}(\text{Br})\text{CH}(\text{Br})\text{CO}-$), 41.09 ($-\text{NHCH}_2\text{CO}_2\text{CH}_2\text{CH}_3$), 14.11 ($-\text{NHCH}_2\text{CO}_2\text{CH}_2\text{CH}_3$).

Note: The signals at 169.18 and 167.13 may be interchangeable. The signals at 51.44 and 48.23 may also be interchangeable.

Mass spectrum: $[\text{M}+\text{H}]^+$ found: 391.9231 $\text{C}_{13}\text{H}_{16}\text{NO}_3\text{Br}_2$ requires 391.94967.

***N*-(3-Phenyl-2,3-dibromopropionyl)-L-leucine methyl ester (6b)**

N-(3-Phenyl-2,3-dibromopropionyl)-L-leucine methyl ester was furnished by the method described for the synthesis of compound (6a). A solution of bromine in carbon tetrachloride (20ml) was added dropwise at 0°C to a stirring solution of *N-trans*-cinnamoyl-L-leucine methyl ester (2.75g, 0.01mol) in carbon tetrachloride. Recrystallization from ethyl acetate/petroleum afforded a mixture of isomers of *N*-(3-phenyl-2,3-dibromopropionyl)-L-leucine methyl ester as an off-white crystalline solid (2.52g, 58%).

m.p. $136-140^\circ\text{C}$ (uncorrected).

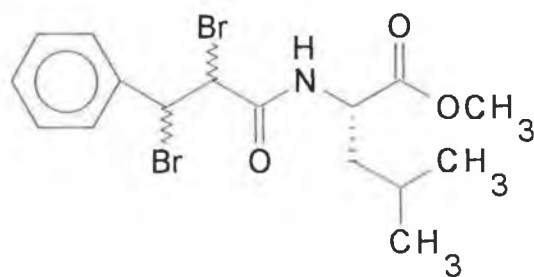

Spectroscopic analysis

i.r. ν_{\max} (KBr): 3281 (NH), 2968, 1744 (ester C=O), 1666 (amide C=O), 1559, 1445, 1388, 1346, 1274, 1202, 1153 cm^{-1}

^1H -n.m.r.(400MHz) δ (CDCl_3): 0.93-1.00 (12H, m, $-\text{NHCH}(\text{CH}_2\text{CH}(\text{CH}_3)_2)\text{CO}_2\text{CH}_3$) 1.61-1.84 (6H, m, $-\text{NHCH}(\text{CH}_2\text{CH}(\text{CH}_3)_2)\text{CO}_2\text{CH}_3$) and $-\text{NHCH}(\text{CH}_2\text{CH}(\text{CH}_3)_2)\text{CO}_2\text{CH}_3$, 3.78 (6H, s, $-\text{NHCH}(\text{CH}_2\text{CH}(\text{CH}_3)_2)\text{CO}_2\text{CH}_3$), 4.73-4.84 (4H, m, $\text{PhCH}(\text{Br})\text{CH}(\text{Br})\text{CO}-$ and $-\text{NHCH}(\text{CH}_2\text{CH}(\text{CH}_3)_2)\text{CO}_2\text{CH}_3$), 5.44-5.48 (2H, d, $J=11\text{Hz}$, $\text{PhCH}(\text{Br})\text{CH}(\text{Br})\text{CO}-$), 6.59 (2H, t, $J=9.1\text{Hz}$, $-\text{NH}$), 7.31-7.42 (10H, m, ArH).

^{13}C -n.m.r.(100MHz) δ (CDCl_3): 172.98, 172.94 ($-\text{NHCH}(\text{CH}_2\text{CH}(\text{CH}_3)_2)\text{CO}_2\text{CH}_3$), 166.51 ($\text{PhCH}(\text{Br})\text{CH}(\text{Br})\text{CO}-$), 138.04, 138.03, 129.21, 129.18, 128.78, 128.74, 128.21, 128.17 (aromatic carbons), 51.40, 51.20 ($-\text{NHCH}(\text{CH}_2\text{CH}(\text{CH}_3)_2)\text{CO}_2\text{CH}_3$), 51.14, 50.80 49.92, 49.44 ($\text{PhCH}(\text{Br})\text{CH}(\text{Br})\text{CO}-$ and $\text{PhCH}(\text{Br})\text{CH}(\text{Br})\text{CO}-$), 41.67 ($-\text{NHCH}(\text{CH}_2\text{CH}(\text{CH}_3)_2)\text{CO}_2\text{CH}_3$), 24.80 ($-\text{NHCH}(\text{CH}_2\text{CH}(\text{CH}_3)_2)\text{CO}_2\text{CH}_3$), 22.78 ($-\text{NHCH}(\text{CH}_2\text{CH}(\text{CH}_3)_2)\text{CO}_2\text{CH}_3$), 22.01, 21.94 ($-\text{NHCH}(\text{CH}_2\text{CH}(\text{CH}_3)_2)\text{CO}_2\text{CH}_3$)

Mass spectrum: $[\text{M}+\text{H}]^+$ found: 434.1722 $\text{C}_{16}\text{H}_{22}\text{NO}_3\text{Br}_2$ requires 433.99659

N-3,5-Dinitrobenzoyl-L-alanine (7a)

Finely powdered 3,5-dinitrobenzoyl chloride (2.32g, 0.01mol) was added to a solution of L-alanine (0.89g, 0.01mol) in 1M sodium hydroxide (20ml). The mixture was shaken vigorously for 5min in a stoppered flask, filtered and the filtrate acidified with 10% hydrochloric acid. The resulting precipitate was filtered and recrystallized from ethanol/water to yield N-3,5-dinitrobenzoyl-L-alanine as white needles (917mg, 32.4%). m.p. 170-172°C (uncorrected). Lit. 177°C.¹²¹

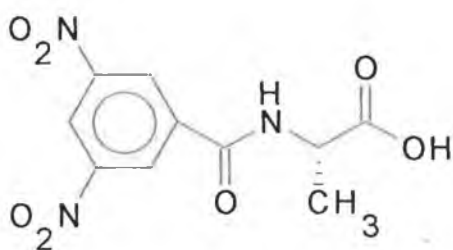

Spectroscopic analysis

i.r. ν_{\max} (KBr): 3300 (OH), 1725 (carboxylic acid C=O), 1650 (amide C=O), 1600,1350 cm^{-1} .

$^1\text{H-n.m.r.}$ (400MHz) δ (DMSO): 1.43 (3H, d, $J=7.4\text{Hz}$, $-\text{NHCH}(\underline{\text{CH}_3})\text{CO}_2\text{H}$) 4.44-4.51 (1H, m, $-\text{NHCH}(\underline{\text{CH}_3})\text{CO}_2\text{H}$), 8.96 (1H, t, $J=2\text{Hz}$, ArH 4), 9.09 (2H, d, $J=2\text{Hz}$, ArH 2&6), 9.47 (1H, d, $J=6.9\text{Hz}$ -NH).

$^{13}\text{C-n.m.r.}$ (100MHz) δ (DMSO): 173.73 ($-\text{NHCH}(\underline{\text{CH}_3})\underline{\text{C}}\text{O}_2\text{H}$), 162.11 ($(\text{O}_2\text{N})_2\text{Ph}\underline{\text{C}}\text{O}-$), 148.29, 136.31, 127.73, 121.14 (aromatic carbons), 48.74 ($-\text{NHCH}(\underline{\text{CH}_3})\text{CO}_2\text{H}$), 16.77 ($-\text{NHCH}(\underline{\text{C}}\text{H}_3)\text{CO}_2\text{H}$).

N-3,5-Dinitrobenzoyl-L-leucine (7b)

N-3,5-Dinitrobenzoyl-L-leucine was afforded by the method used for *N*-3,5-dinitrobenzoyl-L-alanine. Finely powdered 3,5-dinitrobenzoyl chloride (2.32g, 0.01mol) was added to a solution of L-leucine (1.31g, 0.01mol) in sodium hydroxide (1M, 20ml). Recrystallization from ethanol/water furnished *N*-3,5-dinitrobenzoyl-L-leucine as yellow needles (993mg, 28.7%). m.p. 178-180°C (uncorrected) Lit 186-188°C.¹²¹

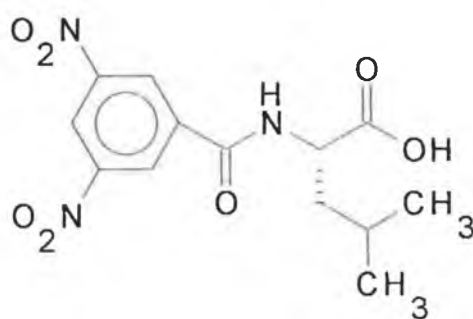

Spectroscopic analysis

i.r. ν_{\max} (KBr): 3400 (OH), 1725 (carboxylic acid C=O), 1650 (amide C=O), 1550, 1350 cm^{-1} .

$^1\text{H-n.m.r.}$ (400MHz) δ (DMSO): 0.87-0.94 (6H, d, $J=6.4\text{Hz}$, $-\text{NHCH}(\text{CH}_2\text{CH}(\text{CH}_3)_2)\text{CO}_2\text{H}$), 1.59-1.82 (3H, m, $-\text{NHCH}(\text{CH}_2\text{CH}(\text{CH}_3)_2)\text{CO}_2\text{H}$ and $-\text{NHCH}(\text{CH}_2\text{CH}(\text{CH}_3)_2)\text{CO}_2\text{H}$), 4.47-4.53 (1H, m, $-\text{NHCH}(\text{CH}_2\text{CH}(\text{CH}_3)_2)\text{CO}_2\text{H}$), 8.38 (1H, d, $J=7.9\text{Hz}$, $-\text{NH}$), 8.96 (1H, t, $J=2\text{Hz}$, ArH 4), 9.10 (2H, d, $J=2\text{Hz}$, ArH 2&6).

^{13}C -n.m.r.(100MHz) δ (DMSO): 173.72 (-NHCH(CH₂CH(CH₃)₂)CO₂H), 162.45 ((O₂N)₂PhCO), 148.31, 136.27, 127.76, 121.16 (aromatic carbons), 51.43 (-NHCH(CH₂CH(CH₃)₂)CO₂H), 41.02 (-NHCH(CH₂CH(CH₃)₂)CO₂H), 24.52 (-NHCH(CH₂CH(CH₃)₂)CO₂H), 22.99, 21.12 (-NHCH(CH₂CH(CH₃)₂)CO₂H).

N-3,5-Dinitrobenzoyl-L-isoleucine (7c)

N-3,5-Dinitrobenzoyl-L-isoleucine was furnished by the method used for *N*-3,5-dinitrobenzoyl-L-alanine. Finely powdered 3,5-dinitrobenzoyl chloride (2.32g, 0.01mol) was added to a solution of L-isoleucine (1.31g, 0.01mol) in sodium hydroxide (1M, 20ml). Recrystallization from ethanol/water yielded *N*-3,5-dinitrobenzoyl-L-isoleucine¹²¹ as pale yellow needles (729mg, 22.4%).

m.p. 160-166°C (uncorrected).

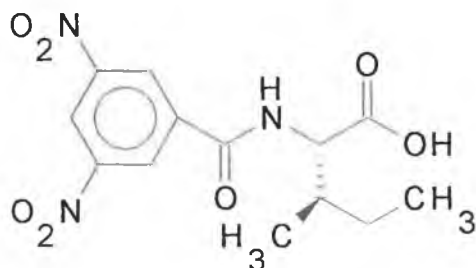

Spectroscopic analysis

i.r. ν_{max} (KBr): 3350 (OH), 1720 (carboxylic acid C=O), 1650 (amide C=O), 1600, 1350 cm^{-1} .

^1H -n.m.r.(400MHz) δ (DMSO): 0.85-0.95 (6H, m, $-\text{NHCH}(\text{CH}(\text{CH}_3)\text{CH}_2\text{CH}_3)\text{CO}_2\text{H}$ and $-\text{NHCH}(\text{CH}(\text{CH}_3)\text{CH}_2\text{CH}_3)\text{CO}_2\text{H}$) 1.23-1.34 (1H, m, $-\text{NHCH}(\text{CH}(\text{CH}_3)\text{CH}_2\text{CH}_3)\text{CO}_2\text{H}$), 1.46-1.56 (1H, m, $-\text{NHCH}(\text{CH}(\text{CH}_3)\text{CH}_2\text{CH}_3)\text{CO}_2\text{H}$), 1.94-2.02 (1H, m, $-\text{NHCH}(\text{CH}(\text{CH}_3)\text{CH}_2\text{CH}_3)\text{CO}_2\text{H}$), 4.39-4.42 (1H, m, $-\text{NHCH}(\text{CH}(\text{CH}_3)\text{CH}_2\text{CH}_3)\text{CO}_2\text{H}$), 8.96 (1H, t, $J=2\text{Hz}$, ArH 4), 9.09 (1H, d, $J=2\text{Hz}$, ArH 2&6), 9.31 (1H, d, $J=7.9\text{Hz}$, $-\text{NH}$).

^{13}C -n.m.r.(100MHz) δ (DMSO): 172.71 ($-\text{NHCH}(\text{CH}(\text{CH}_3)\text{CH}_2\text{CH}_3)\text{CO}_2\text{H}$), 162.81 ($(\text{O}_2\text{N})_2\text{PhCO}-$), 148.16, 136.46, 128.03, 121.08 (aromatic protons), 57.80 ($-\text{NHCH}(\text{CH}(\text{CH}_3)\text{CH}_2\text{CH}_3)\text{CO}_2\text{H}$), 35.88 ($-\text{NHCH}(\text{CH}(\text{CH}_3)\text{CH}_2\text{CH}_3)\text{CO}_2\text{H}$), 25.15 ($-\text{NHCH}(\text{CH}(\text{CH}_3)\text{CH}_2\text{CH}_3)\text{CO}_2\text{H}$), 15.67, 11.13 ($-\text{NHCH}(\text{CH}(\text{CH}_3)\text{CH}_2\text{CH}_3)\text{CO}_2\text{H}$ and $-\text{NHCH}(\text{CH}(\text{CH}_3)\text{CH}_2\text{CH}_3)\text{CO}_2\text{H}$).

Note: The signals at 15.67 and 11.13 may be interchangeable.

N-3,5-Dinitrobenzoyl-D-leucine (7d)

The synthesis of *N*-3,5-dinitrobenzoyl-D-leucine was achieved by the method used for compound *N*-3,5-dinitrobenzoyl-L-alanine. Finely powdered 3,5-dinitrobenzoyl chloride (2.32g, 0.01mol) was added to a solution of D-leucine (1.31g, 0.01mol) in sodium hydroxide (1M, 20ml). Recrystallization from ethanol/water gave *N*-3,5-dinitrobenzoyl-D-leucine as yellow needles (856mg, 26.3%). m.p. 180-184°C (uncorrected). Lit. 187°C.¹²¹

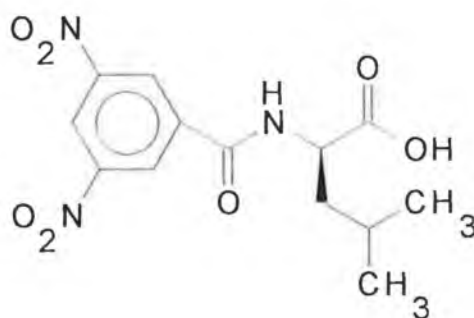

Spectroscopic analysis

i.r. ν_{\max} (KBr): 3400 (OH), 1725 (carboxylic acid C=O), 1650 (amide C=O), 1550, 1350 cm^{-1} .

^1H -n.m.r.(400MHz) δ (DMSO): 0.88-0.95 (6H, d, $J=6.4\text{Hz}$, $-\text{NHCH}(\text{CH}_2\text{CH}(\text{CH}_3)_2)\text{CO}_2\text{H}$), 1.61-1.83 (3H, m, $-\text{NHCH}(\text{CH}_2\text{CH}(\text{CH}_3)_2)\text{CO}_2\text{H}$ and $-\text{NHCH}(\text{CH}_2\text{CH}(\text{CH}_3)_2)\text{CO}_2\text{H}$), 4.48-4.54 (1H, m, $\text{NHCH}(\text{CH}_2\text{CH}(\text{CH}_3)_2)\text{CO}_2\text{H}$), 8.97 (1H, t, $J=2.2\text{Hz}$, ArH 4), 9.11 (2H, d, $J=2\text{Hz}$, ArH 2&6), 9.41 (1H, d, $J=7.9\text{Hz}$, $-\text{NH}$).

^{13}C -n.m.r.(100MHz) δ (DMSO): 173.69 ($-\text{NHCH}(\text{CH}_2\text{CH}(\text{CH}_3)_2)\text{CO}_2\text{H}$), 162.42 ($(\text{O}_2\text{N})_2\text{PhCO}-$), 148.30, 136.23, 127.73, 121.14 (aromatic carbons), 51.40 ($-\text{NHCH}(\text{CH}_2\text{CH}(\text{CH}_3)_2)\text{CO}_2\text{H}$), 24.50 ($-\text{NHCH}(\text{CH}_2\text{CH}(\text{CH}_3)_2)\text{CO}_2\text{H}$), 22.97 ($-\text{NHCH}(\text{CH}_2\text{CH}(\text{CH}_3)_2)\text{CO}_2\text{H}$), 21.10 ($-\text{NHCH}(\text{CH}(\text{CH}_3)_2)\text{CO}_2\text{H}$).

***N*-3,5-Dinitrobenzoyl-L-leucine-L-alanine methyl ester (8)**

N-3,5-Dinitrobenzoyl-L-leucine (3g, 0.01mol) was dissolved in dichloromethane (50ml) with L-alanine methyl ester hydrochloride (1.4g, 0.01mol), *N*-hydroxybenzotriazole (1.35g, 0.01mol) and triethylamine (1.4ml, 0.01mol). The mixture was cooled to 0°C and DCCD (2g, 0.01mol) added. After 30min the reaction temperature was raised to room temperature and the reaction allowed to proceed for 4hr. The precipitated DCU was removed by filtration and the filtrate washed with 5% sodium hydrogen carbonate solution, water, and dried. The solvent was evaporated *in vacuo* and the resulting oil was recrystallized from ethyl acetate/*n*-hexane, to yield the title product^{144,145} as an off-white solid (780mg, 19%).
m.p. 180-184°C (dec) (uncorrected).

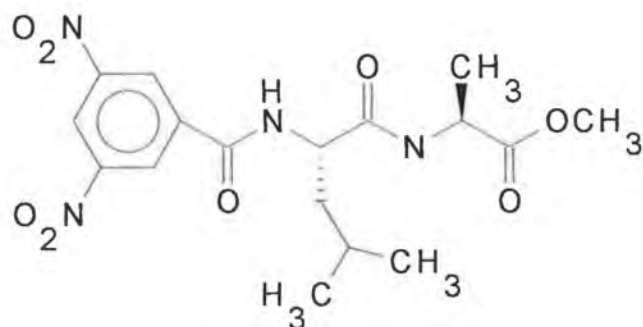

Spectroscopic analysis

i.r. ν_{\max} (KBr): 3279, 3122 (NH), 2959, 1743 (ester C=O), 1649 (amide C=O), 1532, 1452, 1343, 1219 cm^{-1} .

^1H -n.m.r.(400MHz) δ (DMSO): 0.88-0.93 (6H, d, $J=6.9\text{Hz}$, $-\text{NHCH}(\text{CH}_2\text{CH}(\text{CH}_3)_2\text{CO}-)$), 1.3 (3H, d, $J=7.4\text{Hz}$, $-\text{NHCH}(\text{CH}_3)\text{CO}_2\text{CH}_3$), 1.57-1.69 (3H, m, $-\text{NHCH}(\text{CH}_2\text{CH}(\text{CH}_3)_2\text{CO}-)$ and $-\text{NHCH}(\text{CH}_2\text{CH}(\text{CH}_3)_2\text{CO}-)$), 3.6 (3H, s, $-\text{NHCH}(\text{CH}_3)\text{CO}_2\text{CH}_3$), 4.25-4.29 (1H, m, $-\text{NHCH}(\text{CH}_3)\text{CO}_2\text{CH}_3$), 4.60-4.65 (1H, m, $-\text{NHCH}(\text{CH}_2\text{CH}(\text{CH}_3)_2\text{CO}-)$), 8.58 (1H, d, $J=6.4\text{Hz}$, $-\text{NHCH}(\text{CH}_3)\text{CO}_2\text{CH}_3$), 8.95 (1H, t, $J=2.22\text{Hz}$, ArH 4), 9.1 (2H, d, $J=1.96\text{Hz}$, ArH 2&6), 9.3 (1H, d, $J=8.4\text{Hz}$, $-\text{NHCH}(\text{CH}_2\text{CH}(\text{CH}_3)\text{CO}-)$).

^{13}C -n.m.r.(100MHz) δ (DMSO): 172.93, 171.70, 162.18 ($(\text{O}_2\text{N})\text{PhCO}-$, $-\text{NHCH}(\text{CH}_2\text{CH}(\text{CH}_3)_2\text{CO}-$ and $-\text{NHCH}(\text{CH}_3)\text{CO}_2\text{CH}_3$), 148.16, 136.55, 127.81, 120.95 (aromatic carbons), 51.84 ($-\text{NHCH}(\text{CH}_3)\text{CO}_2\text{CH}_3$), 47.63, 40.19 ($-\text{NHCH}(\text{CH}_2\text{CH}(\text{CH}_3)_2\text{CO}-$ and $-\text{NHCH}(\text{CH}_3)\text{CO}_2\text{CH}_3$), 33.35 ($-\text{NHCH}(\text{CH}_2\text{CH}(\text{CH}_3)_2\text{CO}-)$), 24.46, 23.07, 21.33 ($-\text{NHCH}(\text{CH}_2\text{CH}(\text{CH}_3)_2\text{CO}-)$), 17.05, 16.73 ($-\text{NHCH}(\text{CH}_3)\text{CO}_2\text{CH}_3$).

Note: The signals at 172.93, 171.70 and 162.18 may be interchangeable. The signals at 47.63 and 40.19 may also be interchangeable.

N-Toluene-*p*-sulphonyl glycine (9a)

Toluene-*p*-sulphonyl chloride (2g, 0.01mol) in diethyl ether (25ml) was added to a solution of glycine (0.75g, 0.01mol) in 1M sodium hydroxide (20ml). The reaction mixture was stirred vigorously for 4hr at room temperature and the ether layer separated. The aqueous layer was acidified with 10% hydrochloric acid and the precipitate filtered. Recrystallization from ethanol/water gave *N*-toluene-*p*-sulphonyl glycine as white crystals (558mg 24.3%).

m.p. 140-142°C (uncorrected) Lit 150°C.¹²¹

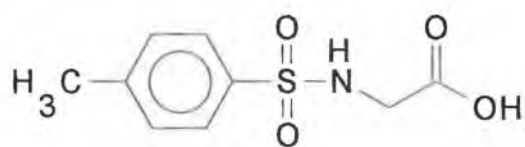

Spectroscopic analysis

i.r. ν_{\max} (KBr): 3300 (OH), 1725 (C=O), 1600, 1400, 1325, 1150 cm^{-1} .

^1H -n.m.r.(400MHz) δ (DMSO): 2.36 (3H, s, $\text{H}_3\text{CPhSO}_2^-$), 3.53 (2H, d, $J=6\text{Hz}$, $-\text{NHCH}_2\text{CO}_2\text{H}$), 7.35 (2H, d, $J=8.4\text{Hz}$, ArH 3&5), 7.66 (2H, d, $J=8.4\text{Hz}$, ArH 2&6), 7.96 (1H, t, $J=6.1\text{Hz}$, $-\text{NH}$).

^{13}C -n.m.r.(100MHz) δ (DMSO): 170.33 ($-\text{NHCH}_2\text{CO}_2\text{H}$), 142.69, 137.82, 129.58, 126.60 (aromatic carbons), 43.81 ($-\text{NHCH}_2\text{CO}_2\text{H}$), 21.03 ($\text{H}_3\text{CPhSO}_2^-$).

N-Toluene-*p*-sulphonyl-L-alanine (9b)

N-Toluene-*p*-sulphonyl-L-alanine was furnished by the method described for *N*-toluene-*p*-sulphonyl glycine. Toluene-*p*-sulphonyl chloride (2g, 0.01mol) in diethyl ether (25ml) was added to a solution of L-alanine (0.89g, 0.01mol) in 1M sodium hydroxide (20ml). Recrystallization from ethanol/water yielded *N*-toluene-*p*-sulphonyl-L-alanine as white needles (649mg, 26.7%).

m.p. 130-132°C (uncorrected) Lit 139°C.¹²¹

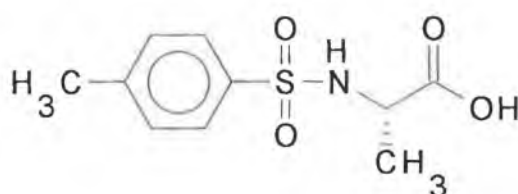

Spectroscopic analysis

i.r. ν_{\max} (KBr): 3300 (OH), 1725 (C=O), 1400, 1350, 1225, 1150 cm^{-1} .

^1H -n.m.r.(400MHz) δ (DMSO): 1.11 (3H, d, $J=7.4\text{Hz}$, -NHCH(CH₃)CO₂H), 2.35 (3H, s, H₃CPhSO₂-), 3.71 (1H, m, -NHCH(CH₃)CO₂H), 7.34 (2H, d, $J=8.4\text{Hz}$, ArH 3&5), 7.66 (2H, d, $J=8.4\text{Hz}$, ArH 2&6), 8.06 (1H, d, $J=8.4\text{Hz}$, -NH).

^{13}C -n.m.r.(100MHz) δ (DMSO): 173.37 (-NHCH(CH₃)CO₂H), 142.63, 138.51, 129.56, 126.57 (aromatic carbons), 51.18 (-NHCH(CH₃)CO₂H), 21.05 (H₃CPhSO₂-), 18.50 (-NHCH(CH₃)CO₂H).

N-Toluene-*p*-sulphonyl-L-valine (9c)

N-Toluene-*p*-sulphonyl-L-valine was synthesized using the method described for *N*-toluene-*p*-sulphonyl glycine. Toluene-*p*-sulphonyl chloride (2g, 0.01mol) in diethyl ether (25ml) was added to a solution of L-valine (1.17g, 0.01mol) in 1M sodium hydroxide (20ml). Recrystallization from ethanol/water furnished *N*-toluene-*p*-sulphonyl-L-valine as a white crystalline solid (998mg, 36.8%).

m.p. 100-102°C (uncorrected). Lit 110°C.¹²¹

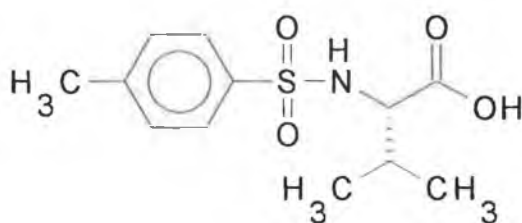

Spectroscopic analysis

i.r. ν_{\max} (KBr): 3293 (OH), 2930, 1708 (C=O), 1475, 1425, 1350, 1150, 1100 cm^{-1} .

¹H-n.m.r.(400MHz) δ (DMSO): 0.75-0.80 (6H, d, $J=6\text{Hz}$, -NHCH((CH(CH₃))₂)CO₂H), 1.87-1.92 (1H, m, -NHCH(CH(CH₃))₂)CO₂H), 2.35 (3H, s, H₃CPhSO₂-), 3.44-3.48 (1H, dd, $J_A=9\text{Hz}$, $J_B=6\text{Hz}$ -HNCH(CH(CH₃))₂)CO₂H), 7.32 (2H, d, $J=8.4\text{Hz}$, ArH 3&5), 7.63 (2H, d, $J=8.4\text{Hz}$, ArH 2&6), 7.89 (1H, d, $J=9\text{Hz}$, -NH).

¹³C-n.m.r.(100MHz) δ (DMSO): 172.18 (-NHCH(CH(CH₃))₂)CO₂H), 142.33, 138.34, 129.28, 126.55 (aromatic carbons), 61.17 (-NHCH(CH(CH₃))₂)CO₂H), 30.38 (-NHCH(CH(CH₃))₂)CO₂H), 20.95 (H₃CPhSO₂-), 19.00, 17.85 (-NHCH(CH(CH₃))₂)CO₂H).

N-Toluene-*p*-sulphonyl-L-leucine (9d)

The synthesis of *N*-toluene-*p*-sulphonyl-L-leucine was achieved using the procedure described for *N*-toluene-*p*-sulphonyl glycine. Toluene-*p*-sulphonyl chloride (2g, 0.01mol) in diethyl ether (25ml) was added to a solution of L-leucine (1.31g, 0.01mol) in 1M sodium hydroxide (20ml). Recrystallization from ethanol/water yielded *N*-toluene-*p*-sulphonyl-L-leucine as white crystals (680mg, 23.8%).

m.p. 116-118°C (uncorrected). Lit. 124°C.¹²¹

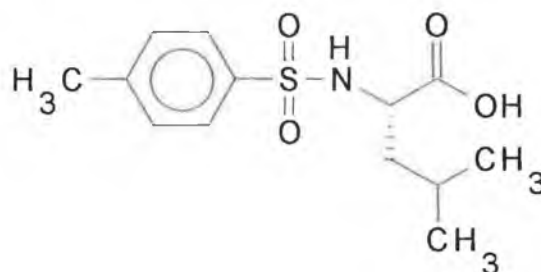

Spectroscopic analysis

i.r. ν_{\max} (KBr): 3300, 1725, 1350, 1150 cm^{-1} .

^1H -n.m.r.(400MHz) δ (DMSO): 0.65-0.79 (6H, d, $J=6\text{Hz}$, $-\text{NHCH}(\text{CH}_2\text{CH}(\text{CH}_3)_2)\text{CO}_2\text{H}$), 1.29-1.41 (2H, m, $-\text{NHCH}(\text{CH}_2\text{CH}(\text{CH}_3)_2)\text{CO}_2\text{H}$), 1.49-1.59 (1H, m, $-\text{NHCH}(\text{CH}_2\text{CH}(\text{CH}_3)_2)\text{CO}_2\text{H}$), 3.58-3.64 (1H, m, $-\text{NHCH}(\text{CH}_2\text{CH}(\text{CH}_3)_2)\text{CO}_2\text{H}$), 7.33 (2H, d, $J=8.5\text{Hz}$, ArH 3&5), 7.63 (2H, d, $J=8.5\text{Hz}$, ArH 2&6), 8.05 (1H, d, $J=8.8\text{Hz}$, $-\text{NH}$).

^{13}C -n.m.r.(100MHz) δ (DMSO): 173.33 ($-\text{NHCH}(\text{CH}_2\text{CH}(\text{CH}_3)_2)\text{CO}_2\text{H}$), 142.49, 138.31, 129.41, 126.57 (aromatic carbons), 53.94 ($-\text{NHCH}(\text{CH}_2\text{CH}(\text{CH}_3)_2)\text{CO}_2\text{H}$), 40.95 ($-\text{NHCH}(\text{CH}_2\text{CH}(\text{CH}_3)_2)\text{CO}_2\text{H}$), 23.89 ($-\text{NHCH}(\text{CH}_2\text{CH}(\text{CH}_3)_2)\text{CO}_2\text{H}$), 22.64 ($\text{H}_3\text{CPhSO}_2-$), 21.03, 21.01 ($-\text{NHCH}(\text{CH}_2\text{CH}(\text{CH}_3)_2)\text{CO}_2\text{H}$).

N-Toluene-*p*-sulphonyl-L-isoleucine (9e)

N-Toluene-*p*-sulphonyl-L-isoleucine was by the method described for *N*-toluene-*p*-sulphonyl glycine. Toluene-*p*-sulphonyl chloride (2g, 0.01mol) in diethyl ether (25ml) was added to a solution of L-isoleucine (1.31g, 0.01mol) in 1M sodium hydroxide (20ml). Recrystallization from ethanol/water gave *N*-toluene-*p*-sulphonyl-L-isoleucine (676mg, 26.7%), as white needles.

m.p. 130-132°C (uncorrected) Lit 141°C.¹²¹

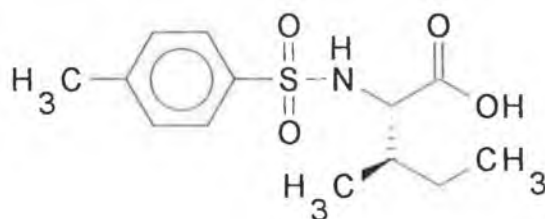

Spectroscopic analysis

i.r. ν_{\max} (KBr): 3400 (OH), 1700 (C=O), 1325, 1150, 1075 cm^{-1} .

^1H -n.m.r.(400MHz) δ (DMSO): 0.71-0.78 (6H, m, -NHCH(CH(CH₃)CH₂CH₃)CO₂H, and -NH(CH(CH(CH₃)CH₂CH₃)) 1.01-1.12 (1H, m, -NHCH(CH(CH₃)CH₂CH₃), 1.27-1.38 (1H, m, -NHCH(CH(CH₃)CH₂CH₃), 1.59-1.66 (1H, m, -NHCH(CH(CH₃)CH₂CH₃)CO₂H), 2.35 (3H, s, H₃CPhSO₂-), 3.48-3.51 (1H, m, -NHCH(CH(CH₃)CH₂CH₃)CO₂H), 7.33 (2H, d, J=8.36Hz, ArH 3&5), 7.63 (2H, d, J=8.36Hz, ArH 2&6), 7.95 (1H, d, J=9.32 Hz, -NH).

^{13}C -n.m.r.(100MHz) δ (DMSO): 172.21 (-NHCH(CH(CH₃)CH₂CH₃)CO₂H), 142.42, 138.30, 129.35, 126.60 (aromatic carbons), 60.00 (-NHCH(CH(CH₃)CH₂CH₃)CO₂H), 36.93 (-NHCH(CH(CH₃)CH₂CH₃)CO₂H), 24.39 (-NHCH(CH(CH₃)CH₂CH₃)CO₂H), 21.01 (H₃CPhSO₂-), 15.41, 10.94 (-NHCH(CH(CH₃)CH₂CH₃)CO₂H and -NHCH(CH(CH₃)CH₂CH₃)CO₂H).

Note: The signals at 15.41 and 10.94 may be interchangeable.

N-Toluene-*p*-sulphonyl-L-isoleucine methyl ester (9f)

The synthesis of *N*-toluene-*p*-sulphonyl-L-isoleucine methyl ester was achieved by the procedure described for *N*-*trans*-cinnamoyl glycine methyl ester. Thionyl chloride (6.7g, 0.005mol), was added to methanol (20ml), at 0°C. *N*-Toluene-*p*-sulphonyl-L-isoleucine (1.43g, 0.005mol.), was added portionwise, and the temperature was slowly raised to 40°C. Recrystallization from ethyl acetate/petroleum ether furnished *N*-toluene-*p*-sulphonyl-L-isoleucine methyl ester as white needles (584mg, 39%).

m.p.76-78°C (uncorrected).

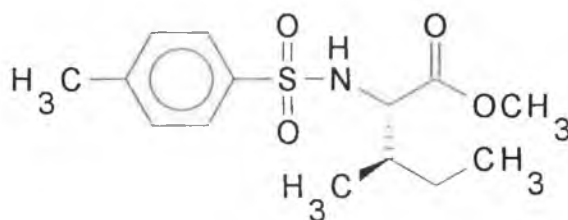

Spectroscopic analysis

i.r. ν_{max} (KBr): 3281 (NH), 2975, 1744 (C=O), 1602, 1438, 1353, 1324, 1253, 1203 cm^{-1} .

^1H -n.m.r.(400MHz) δ (DMSO): 0.70-0.74 (6H, m, $-\text{NHCH}(\text{CH}(\underline{\text{CH}}_3)\text{CH}_2\text{CH}_3)\text{CO}_2\text{CH}_3$ and $-\text{NHCH}(\text{CH}(\text{CH}_3)\text{CH}_2\underline{\text{CH}}_3)\text{CO}_2\text{CH}_3$) 1.02-1.14 (1H, m, $-\text{NHCH}(\text{CH}(\text{CH}_3)\underline{\text{CH}}_2\text{CH}_3)\text{CO}_2\text{CH}_3$), 1.31-1.41 (1H, m, $-\text{NHCH}(\text{CH}(\text{CH}_3)\underline{\text{CH}}_2\text{CH}_3)\text{CO}_2\text{CH}_3$), 1.58-1.67 (1H, m, $-\text{NHCH}(\text{CH}(\text{CH}_3)\underline{\text{CH}}_2\text{CH}_3)\text{CO}_2\text{CH}_3$), 2.36 (3H, s, $\text{H}_3\text{CPhSO}_2^-$), 3.3 (3H, s, $-\text{NHCH}(\text{CH}(\text{CH}_3)\text{CH}_2\underline{\text{CH}}_3)\text{CO}_2\text{CH}_3$), 3.53 (1H, m, $-\text{NHCH}(\text{CH}(\text{CH}_3)\text{CH}_2\underline{\text{CH}}_3)\text{CO}_2\text{CH}_3$), 7.35 (2H, d, $J=7.8\text{Hz}$, ArH 3&5), 7.59-7.61 (2H, d, $J=7.8\text{Hz}$, ArH 2&6), 8.21 (1H, s, $-\text{NH}$).

^{13}C -n.m.r.(100MHz) δ (DMSO): 171.21 ($-\text{NHCH}(\text{CH}(\text{CH}_3)\text{CH}_2\underline{\text{CH}}_3)\text{CO}_2\text{CH}_3$), 142.63, 137.86, 129.37, 126.57 (aromatic carbons), 62.73 ($-\text{NHCH}(\text{CH}(\text{CH}_3)\text{CH}_2\underline{\text{CH}}_3)\text{CO}_2\text{CH}_3$), 59.96 ($-\text{NHCH}(\text{CH}(\text{CH}_3)\text{CH}_2\underline{\text{CH}}_3)\text{CO}_2\text{CH}_3$), 36.63 ($-\text{NHCH}(\underline{\text{CH}}(\text{CH}_3)\text{CH}_2\text{CH}_3)\text{CO}_2\text{CH}_3$), 24.46 ($-\text{NHCH}(\text{CH}(\text{CH}_3)\underline{\text{CH}}_2\text{CH}_3)\text{CO}_2\text{CH}_3$), 20.98 ($\text{H}_3\text{CPhSO}_2^-$), 15.11, 10.52 ($-\text{NHCH}(\text{CH}(\underline{\text{CH}}_3)\text{CH}_2\text{CH}_3)\text{CO}_2\text{CH}_3$) and $-\text{NHCH}(\text{CH}(\text{CH}_3)\text{CH}_2\underline{\text{CH}}_3)\text{CO}_2\text{CH}_3$).

Note: The signals at 15.11 and 10.52 may be interchangeable.

***N*-Toluene-*p*-sulphonyl-*L*-isoleucine ethyl ester (9g)**

N-Toluene-*p*-sulphonyl-*L*-isoleucine ethyl ester was afforded by the procedure for the synthesis of *N-trans*-cinnamoyl glycine ethyl ester. Thionyl chloride (6.7g, 0.005mol) was added to ethanol (20ml) at -4°C . *N*-Toluene-*p*-sulphonyl-*L*-isoleucine (1.43g, 0.005mol) was added portionwise and the temperature was slowly raised to 40°C . Recrystallization from ethyl acetate/petroleum ether yielded *N*-toluene-*p*-sulphonyl-*L*-isoleucine ethyl ester as white needles (658mg, 42%).

m.p. $48-50^\circ\text{C}$ (uncorrected).

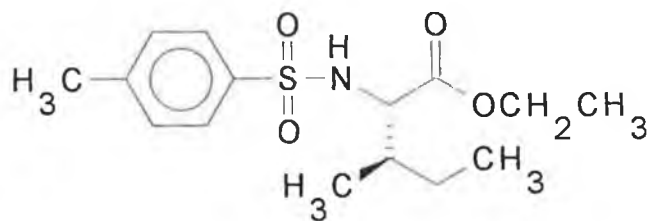

Spectroscopic analysis

i.r. ν_{\max} (KBr): 3267 (NH), 2975, 1730 (C=O), 1452, 1338, 1203 cm^{-1} .

^1H -n.m.r.(400MHz) δ (DMSO): 0.71-0.75 (6H, -NHCH(CH(CH₃)CH₂CH₃)CO₂CH₂CH₃) and -NHCH(CH(CH₃)CH₂CH₃)CO₂CH₂CH₃), 0.95-0.99 (3H, t, J=7.1Hz, -NHCH(CH(CH₃)CH₂CH₃)CO₂CH₂CH₃), 1.03-1.14 (1H, m, -NHCH(CH(CH₃)CH₂CH₃)CO₂CH₂CH₃), 1.32-1.42 (1H, m, -NHCH(CH(CH₃)CH₂CH₃)CO₂CH₂CH₃), 1.59-1.66 (1H, m, -NHCH(CH(CH₃)CH₂CH₃)CO₂CH₂CH₃), 2.35 (3H, s, H₃CPhSO₂-), 3.49-3.53 (1H, m, -NHCH(CH(CH₃)CH₂CH₃)CO₂CH₂CH₃), 3.69-3.78 (2H, m, -NHCH(CH(CH₃)CH₂CH₃)CO₂CH₂CH₃), 7.34 (2H, d, J=8.4Hz, ArH 3&5), 7.6 (2H, d, J=8.4Hz, ArH 2&6), 8.19 (1H, d, J=9.4Hz, -NH).

^{13}C -n.m.r.(100MHz) δ (DMSO): 170.70 (-NHCH(CH(CH₃)CH₂CH₃)CO₂CH₂CH₃), 142.60, 138.20, 129.36, 126.59 (aromatic carbons), 60.31 (-NHCH(CH(CH₃)CH₂CH₃)CO₂CH₂CH₃), 59.96 (-NHCH(CH(CH₃)CH₂CH₃)CO₂CH₂CH₃), 36.76 (-NHCH(CH(CH₃)CH₂CH₃)CO₂CH₂CH₃), 24.48 (-NHCH(CH(CH₃)CH₂CH₃)CO₂CH₂CH₃), 21.04 ((H₃C)PhSO₂-) 15.12, 13.76, 10.58 (-NHCH(CH(CH₃)CH₂CH₃)CO₂CH₂CH₃, -NHCH(CH(CH₃)CH₂CH₃)CO₂CH₂CH₃ and

-NHCH(CH(CH₃)CH₂CH₃)CO₂CH₂CH₃).

Note: The signals at 15.12, 13.76 and 10.58 may be interchangeable.

N-Toluene-*p*-sulphonyl-*D*-leucine (9h)

The synthesis of *N*-toluene-*p*-sulphonyl-*D*-leucine was achieved by the method described for *N*-toluene-*p*-sulphonyl glycine. Toluene-*p*-sulphonyl chloride (2g, 0.01mol) in diethyl ether (25ml) was added to a solution of *D*-leucine (1.31g, 0.01mol) in 1M sodium hydroxide (20ml). Recrystallization from ethanol/water furnished *N*-toluene-*p*-sulphonyl-*D*-leucine as white needles (725mg, 25.4%).

m.p. 118-122°C (uncorrected). Lit. 124°C.¹²¹

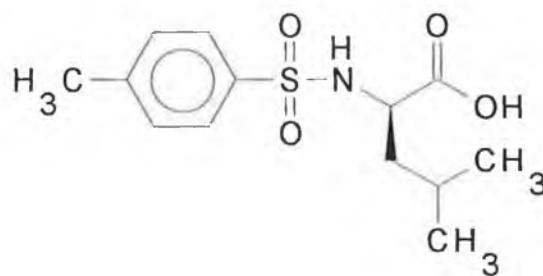

Spectroscopic analysis

i.r. ν_{\max} (KBr): 3300 (OH), 1725 (C=O), 1350, 1150cm⁻¹.

¹H-n.m.r.(400MHz) δ (DMSO): 0.66-0.80 (6H, d, J=6.4Hz, -NHCH(CH₂CH(CH₃)₂)CO₂H), 1.33-1.38 (2H, m, -NHCH(CH₂CH(CH₃)₂)CO₂H), 1.53-1.56 (1H, m, -NHCH(CH₂CH(CH₃)₂)CO₂H), 2.35 (3H, s, H₃CPhSO₂-), 3.61 (1H, m, -NHCH(CH₂CH(CH₃)₂)CO₂H), 7.34 (2H, d, J=7.9Hz, ArH 3&5), 7.63 (2H, d, J=7.9Hz, ArH 2&6), 8.07 (1H, d, J=8.84Hz, -NH), 12.58 (1H, s, -NHCH(CH₂CH(CH₃)₂)CO₂H).

^{13}C -n.m.r.(100MHz) δ (DMSO): 173.32 (-NHCH(CH₂CH(CH₃)₂)CO₂H), 142.48, 138.30, 129.41, 126.56 (aromatic carbons), 53.91 (-NHCH(CH₂CH(CH₃)₂)CO₂H), 40.93 (-NHCH(CH₂CH(CH₃)₂)CO₂H), 23.88 (-NHCH(CH₂CH(CH₃)₂)CO₂H), 22.64 ((H₃C)PhSO₂-), 21.01 (-NHCH(CH(CH₂CH(CH₃)₂)CO₂H).

N-3-Nitrophthaloyl-L-alanine (10a)

L-alanine (1g, 0.01mol) and 3-nitrophthalic anhydride (2.6g, 0.01mol) were heated in an oil bath at 145-150°C for 20min. The reaction mixture was poured into a small mortar and allowed to solidify. Recrystallisation of the solid from ethanol/water yielded *N*-3-nitrophthaloyl-L-alanine¹⁴⁶ as very fine pale yellow needles (877mg, 33.2%).
m.p. 148-150°C (uncorrected).

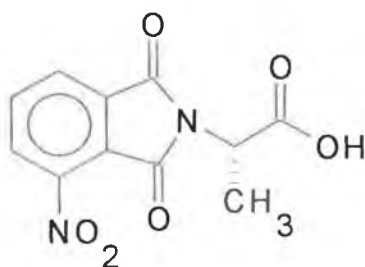

Spectroscopic analysis

i.r. ν_{max} (KBr): 1725 (carboxylic acid C=O), 1550, 1375 cm^{-1} .

^1H -n.m.r.(400MHz) δ (DMSO): 1.53 (3H, d, $J=7.3\text{Hz}$, -NCH(CH₃)CO₂H), 4.89 (1H, q, $J=7.3\text{Hz}$, -NCH(CH₃)CO₂H) 8.08 (1H, t, $J=7\text{Hz}$, ArH 5), 8.2 (1H, d, $J=7\text{Hz}$, ArH 6), 8.31 (1H, d, $J=7\text{Hz}$, ArH 4), 13.22 (1H, s, -NCH(CH₃)CO₂H).

^{13}C -n.m.r.(100MHz) δ (DMSO): 170.70 (-NCH(CH₃)CO₂H), 165.19, 162.56 (phthaloyl carbonyls), 144.41, 136.66, 133.12, 128.74, 127.18, 122.62 (aromatic carbons), 47.50 (-NCH(CH₃)CO₂H), 14.56 (-NCH(CH₃)CO₂H).

N-3-Nitrophthaloyl-L-leucine (10b)

L-leucine (1g, 0.008mol) and 3-nitrophthalic anhydride (2.6g, 0.01mol) were heated in an oil bath at 145-150°C for 20min. The reaction mixture was poured into a small mortar and allowed to solidify. Purification by column chromatography on silica gel [chloroform (to which a small amount of acetic acid was added)] furnished *N*-3-nitrophthaloyl-L-leucine¹⁴⁶ as a yellow oil (951mg, 38.8%).

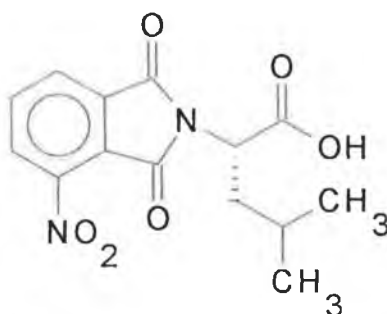

Spectroscopic analysis

i.r. ν_{max} (CHCl₃) 1725 (carboxylic acid C=O), 1550, 1400, 1350cm⁻¹.

^1H -n.m.r.(400MHz) δ (DMSO): 0.86 (6H, d, J=6Hz, -NCH(CH₂CH(CH₃)₂)CO₂H), 1.47-1.54 (1H, m, -NCH(CH₂CH(CH₃)₂)CO₂H), 1.79-1.87 (1H, m, -NCH(CH₂CH(CH₃)₂)CO₂H), 2.08-2.15 (1H, m, -NCH(CH₂CH(CH₃)₂)CO₂H), 4.77-4.81 (1H, m, -NCH(CH₂CH(CH₃)₂)CO₂H), 8.09 (1H, t, J=7.9Hz, ArH 5), 8.21 (1H, d, J=7.9Hz, ArH 6), 8.32 (1H, d, J=7.9Hz, ArH 4).

^{13}C -n.m.r.(100MHz) δ (DMSO): 170.49 (-NCH(CH₂CH(CH₃)₂)CO₂H), 165.56, 162.86 (phthaloyl carbonyls), 144.52, 136.77, 132.90, 128.98, 127.37, 122.52 (aromatic carbons), 50.70 (-NCH(CH₂CH(CH₃)₂)CO₂H), 36.72 (-NCH(CH₂CH(CH₃)₂)CO₂H), 24.36, (-NCH(CH₂CH(CH₃)₂)CO₂H), 23.06, 20.87 (-NCH(CH₂CH(CH₃)₂)CO₂H).

***N*-3-Nitrophthaloyl-L-leucine methyl ester (10c)**

Thionyl chloride (0.6g, 0.005mol) was added to methanol (20ml) at 0°C. *N*-3-nitrophthaloyl-L-leucine (1.5g, 0.005mol) in methanol (5ml) was added dropwise and the temperature was slowly raised to 40°C. The reaction mixture was stirred for 4hr at 40°C and the excess methanol removed *in vacuo*. The resulting yellow oil was dissolved in ethyl acetate, washed with 10% sodium hydrogen carbonate and water. The organic layer was dried with magnesium sulphate filtered and the solvent removed *in vacuo*. Purification by column chromatography [chloroform] yielded *N*-3-nitrophthaloyl-L-leucine methyl ester as a yellow oil (677mg, 42.3%).

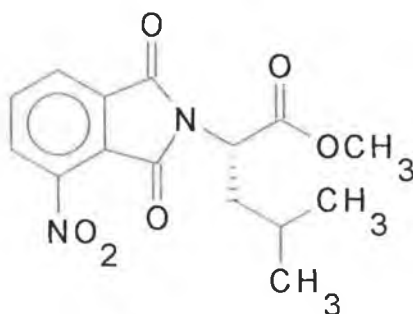

Spectroscopic analysis

i.r. ν_{max} (CHCl₃): 1787, 1723 (ester C=O), 1538, 1466, 1388cm⁻¹.

$^1\text{H-n.m.r.}$ (400MHz) δ (CDCl_3): 0.89 (6H, d, $J=6.9\text{Hz}$, $-\text{NCH}(\text{CH}_2\text{CH}(\text{CH}_3)_2)\text{CO}_2\text{CH}_3$), 1.34-1.47 (1H, m, $-\text{NCH}(\text{CH}_2\text{CH}(\text{CH}_3)_2)\text{CO}_2\text{CH}_3$) 1.89-1.96 (1H, m, $-\text{NCH}(\text{CH}_2\text{CH}(\text{CH}_3)_2)\text{CO}_2\text{CH}_3$), 2.23-2.30 (1H, m, $-\text{NCH}(\text{CH}_2\text{CH}(\text{CH}_3)_2)\text{CO}_2\text{CH}_3$), 3.69 (3H, s, $-\text{NCH}(\text{CH}_2\text{CH}(\text{CH}_3)_2)\text{CO}_2\text{CH}_3$), 4.92 (1H, dd, $J_A=11.8\text{Hz}$, $J_B=4.44\text{Hz}$, $-\text{NCH}(\text{CH}_2\text{CH}(\text{CH}_3)_2)\text{CO}_2\text{CH}_3$), 7.93-8.10 (3H, m, ArH).

$^{13}\text{C-n.m.r.}$ (100MHz) δ (CDCl_3): 169.53, 165.20, 162.24 ($-\text{NCH}(\text{CH}_2\text{CH}(\text{CH}_3)_2)\text{CO}_2\text{CH}_3$ and phthaloyl carbonyls), 145.08, 135.59, 133.67, 128.84, 127.30, 123.38 (aromatic carbons), 52.86 ($-\text{NCH}(\text{CH}_2\text{CH}(\text{CH}_3)_2)\text{CO}_2\text{CH}_3$), 51.18 ($-\text{NCH}(\text{CH}_2\text{CH}(\text{CH}_3)_2)\text{CO}_2\text{CH}_3$), 36.90 ($-\text{NCH}(\text{CH}_2\text{CH}(\text{CH}_3)_2)\text{CO}_2\text{CH}_3$) 23.01, ($-\text{NCH}(\text{CH}_2\text{CH}(\text{CH}_3)_2)\text{CO}_2\text{CH}_3$) 20.80, 15.18 ($-\text{NCH}(\text{CH}_2\text{CH}(\text{CH}_3)_2)\text{CO}_2\text{CH}_3$).

***N*-3-Nitrophthaloyl-L-leucine ethyl ester (10d)**

N-3-Nitrophthaloyl-L-leucine ethyl ester was afforded by the procedure described for compound *N*-3-nitrophthaloyl-L-leucine methyl ester. Thionyl chloride (0.6g, 0.005mol) was added to ethanol (20ml) at 0°C . *N*-3-Nitrophthaloyl-L-leucine (1.5g, 0.005mol) in ethanol (5ml) was added dropwise and the temperature was slowly raised to 40°C . Purification by column chromatography on silica gel [chloroform] yielded *N*-3-nitrophthaloyl-L-leucine ethyl ester as a yellow oil (622mg, 37.2%).

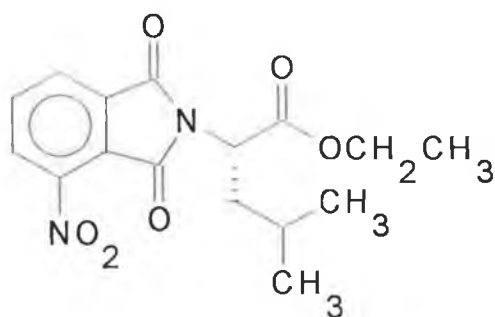

Spectroscopic analysis

i.r. ν_{\max} (CHCl₃): 1773, 1723 (ester C=O), 1545, 1452, 1367cm⁻¹.

¹H-n.m.r.(400MHz) δ (CDCl₃): 0.88 (6H, d, J=6.9Hz, -NCH(CH₂CH(CH₃)₂)CO₂CH₂CH₃),
1.19 (3H, t, J=6.9Hz, -NCH(CH₂CH(CH₃)₂)CO₂CH₂CH₃), 1.41-1.46 (1H, m,
-NCH(CH₂CH(CH₃)₂)CO₂CH₂CH₃), 1.87-1.95 (1H, m,
-NCH(CH₂CH(CH₃)₂)CO₂CH₂CH₃), 2.22-2.29 (1H, m,
-NCH(CH₂CH(CH₃)₂)CO₂CH₂CH₃), 4.11-4.17 (2H, m,
-NCH(CH₂CH(CH₃)₂)CO₂CH₂CH₃), 4.89 (1H, m, -NCH(CH₂CH(CH₃)₂)CO₂CH₂CH₃),
7.92-8.10 (3H, m, ArH).

¹³C-n.m.r.(100MHz) δ (CDCl₃): 169.01, 165.23, 162.28 (-NCH(CH₂CH(CH₃)₂)CO₂CH₂CH₃
and phthaloyl carbonyls), 145.04, 135.59, 133.67, 128.78, 127.24, 123.34 (aromatic
carbons), 61.98 (-NCH(CH₂CH(CH₃)₂)CO₂CH₂CH₃), 51.36
(-NCH(CH₂CH(CH₃)₂)CO₂CH₂CH₃), 36.88 (-NCH(CH₂CH(CH₃)₂)CO₂CH₂CH₃), 24.97
(-NCH(CH₂CH(CH₃)₂)CO₂CH₂CH₃), 23.00, 20.84 (-NCH(CH₂CH(CH₃)₂)CO₂CH₂CH₃),
13.96 (-NCH(CH₂CH(CH₃)₂)CO₂CH₂CH₃).

N-3-Nitrophthaloyl-L-isoleucine (10e)

L-Isoleucine (1g, 0.008mol) and phthalic anhydride (2.6g, 0.01mol) were heated in an oil bath at 145-150°C for 20min. The reaction mixture was poured into a small mortar and allowed to solidify. Purification by column chromatography on silica gel [chloroform (to which a small amount of acetic acid was added)] furnished *N*-3-nitrophthaloyl-L-isoleucine¹⁴⁶ as a yellow oil (666mg, 27.2%).

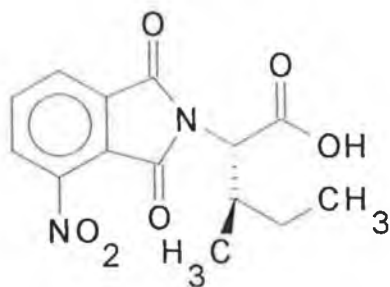

Spectroscopic analysis

i.r. ν_{\max} (CHCl₃): 1725 (carboxylic acid C=O), 1550, 1400, 1350cm⁻¹.

¹H-n.m.r.(400MHz) δ (DMSO): 0.78 (3H, t, J=7.4Hz, -NCH(CH(CH₃)CH₂CH₃)CO₂H), 1.03 (3H, d, J=6.4Hz, -NCH(CH(CH₃)CH₂CH₃)CO₂H), 1.19-1.28 (1H, m, -NCH(CH(CH₃)CH₂CH₃)CO₂H), 1.45-1.52 (1H, m, -NCH(CH(CH₃)CH₂CH₃)CO₂H), 2.30-2.36 (1H, m, -NCH(CH(CH₃)CH₂CH₃)CO₂H), 4.53 (1H, d, J=7.9Hz, -NCH(CH(CH₃)CH₂CH₃)CO₂H), 8.08 (1H, t, J=8Hz, ArH 5), 8.19 (1H, d, J=8Hz, ArH 6), 8.31 (1H, d, J=8Hz, ArH 4).

¹³C-n.m.r.(100MHz) δ (DMSO): 169.49, 165.59, 162.96 (-NCH(CH(CH₃)CH₂CH₃)CO₂H and phthaloyl carbonyls), 144.52, 136.80, 132.80, 128.98, 127.30, 122.38 (aromatic carbons), 57.00 (-NCH(CH(CH₃)CH₂CH₃)CO₂H), 34.09 (-NCH(CH(CH₃)CH₂CH₃)CO₂H), 25.25 (-NCH(CH(CH₃)CH₂CH₃)CO₂H), 16.64, 10.98 (-NHCH(CH(CH₃)CH₂CH₃)CO₂H and -NHCH(CH(CH₃)CH₂CH₃)CO₂H).

Note: The signals at 169.49, 165.59 and 162.96 may be interchangeable. The signals at 16.64 and 10.98 may also be interchangeable.

N-3-Nitrophthaloyl-L-isoleucine methyl ester (10f)

N-3-Nitrophthaloyl-L-isoleucine methyl ester was synthesized by the procedure outlined for compound (10c). Thionyl chloride (0.6g, 0.005mol) was added to methanol (20ml) at 0°C. *N*-3-Nitrophthaloyl-L-isoleucine (1.5g, 0.005mol) in methanol (5ml) was added dropwise, and the temperature was slowly raised to 40°C. Purification by column chromatography [chloroform] yielded the title compound as a yellow oil (636mg, 39.7%).

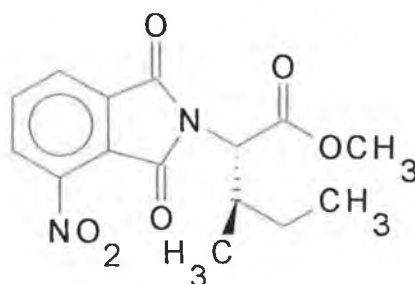

Spectroscopic analysis

i.r. ν_{\max} (CHCl₃): 1787, 1729 (ester C=O), 1542, 1470, 1376cm⁻¹.

¹H-n.m.r.(400MHz) δ (CDCl₃): 0.84 (3H, t, J=7.4Hz, -NCH(CH(CH₃)CH₂CH₃)CO₂CH₃), 1.08 (3H, d, J=6.9Hz, -NCH(CH(CH₃)CH₂CH₃)CO₂CH₃), 1.42-1.51 (1H, m, -NCH(CH(CH₃)CH₂CH₃)CO₂CH₃), 1.42-1.51 (1H, m, -NCH(CH(CH₃)CH₂CH₃), 2.44-2.53 (1H, m, -NCH(CH(CH₃)CH₂CH₃)CO₂CH₃) 3.54 (3H, s, -NCH(CH(CH₃)CH₂CH₃)CO₂CH₃), 4.64 (1H, d, J=8.4Hz, -NCH(CH(CH₃)CH₂CH₃)CO₂CH₃), 7.9-8.12 (3H, m, ArH).

¹³C-n.m.r.(100MHz) δ (CDCl₃): 168.73, 165.28, 162.34 (-NCH(CH(CH₃)CH₂CH₃)CO₂CH₃ and phthaloyl carbonyls), 145.12, 135.50, 133.62, 129.90, 127.50, 123.29 (aromatic carbons), 57.54 (-NCH(CH(CH₃)CH₂CH₃)CO₂CH₃), 52.57

(-NCH(CH(CH₃)CH₂CH₃)CO₂CH₃), 34.44 (-NCH(CH(CH₃)CH₂CH₃)CO₂CH₃), 25.76 (-NCH(CH(CH₃)CH₂CH₃)CO₂CH₃), 16.74, 10.94 (-NCH(CH(CH₃)CH₂CH₃)CO₂CH₃ and -NCH(CH(CH₃)CH₂CH₃)CO₂CH₃).

Note: The signals at 168.73, 165.28 and 162.34 may be interchangeable. The signals at 16.74 and 10.94 may also be interchangeable.

N-3-Nitrophthaloyl-L-isoleucine ethyl ester (10g)

The synthesis of *N*-3-nitrophthaloyl-L-isoleucine ethyl ester was afforded by the method described for *N*-3-nitrophthaloyl-L-leucine ethyl ester. Thionyl chloride (0.6g, 0.005mol) was added to ethanol (20ml) at 0°C. *N*-3-Nitrophthaloyl-L-isoleucine (1.5g, 0.005mol) in ethanol (5ml), was added dropwise and the temperature was slowly raised to 40°C. Purification by column chromatography [chloroform] furnished *N*-3-nitrophthaloyl-L-isoleucine ethyl ester as a yellow oil (448mg, 26.8%).

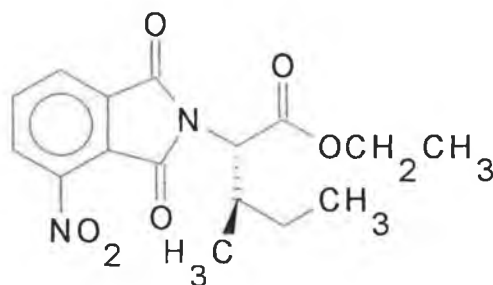

Spectroscopic analysis

i.r. ν_{\max} (CHCl₃): 1780, 1736 (ester (C=O)), 1542, 1376, 1253cm⁻¹.

^1H -n.m.r.(400MHz) $\delta(\text{CDCl}_3)$: 0.85 (3H, t, $J=7.4\text{Hz}$,
-NCH(CH(CH $\underline{\text{C}}\text{H}_3$)CH $\underline{\text{C}}\text{H}_2\text{CH}_3$)CO $\underline{\text{C}}\text{O}_2\text{CH}_2\text{CH}_3$), 1.08 (3H, d, $J=6.9\text{Hz}$,
-NCH(CH(CH $\underline{\text{C}}\text{H}_3$)CH $\underline{\text{C}}\text{H}_2\text{CH}_3$)CO $\underline{\text{C}}\text{O}_2\text{CH}_2\text{CH}_3$), 1.19 (3H, t, $J=7.1\text{Hz}$,
-NCH(CH(CH $\underline{\text{C}}\text{H}_3$)CH $\underline{\text{C}}\text{H}_2\text{CH}_3$)CO $\underline{\text{C}}\text{O}_2\text{CH}_2\text{CH}_3$), 1.43-1.53 (1H, m,
-NCH(CH(CH $\underline{\text{C}}\text{H}_3$)CH $\underline{\text{C}}\text{H}_2\text{CH}_3$)CO $\underline{\text{C}}\text{O}_2\text{CH}_2\text{CH}_3$), 2.45-2.53 (1H, m,
-NCH(CH(CH $\underline{\text{C}}\text{H}_3$)CH $\underline{\text{C}}\text{H}_2\text{CH}_3$)CO $\underline{\text{C}}\text{O}_2\text{CH}_2\text{CH}_3$), 4.16 (2H, q, $J=7.1\text{Hz}$,
-NCH(CH(CH $\underline{\text{C}}\text{H}_3$)CH $\underline{\text{C}}\text{H}_2\text{CH}_3$)CO $\underline{\text{C}}\text{O}_2\text{CH}_2\text{CH}_3$), 4.64 (1H, d, $J=7.9\text{Hz}$,
-NCH(CH(CH $\underline{\text{C}}\text{H}_3$)CH $\underline{\text{C}}\text{H}_2\text{CH}_3$)CO $\underline{\text{C}}\text{O}_2\text{CH}_2\text{CH}_3$), 7.93-8.10 (3H, m, ArH).

Note: The second -NHCH(CH(CH $\underline{\text{C}}\text{H}_3$)CH $\underline{\text{C}}\text{H}_2\text{CH}_3$)CO $\underline{\text{C}}\text{O}_2\text{CH}_2\text{CH}_3$ signal is obscured by the
-NCH(CH(CH $\underline{\text{C}}\text{H}_3$)CH $\underline{\text{C}}\text{H}_2\text{CH}_3$)CO $\underline{\text{C}}\text{O}_2\text{CH}_2\text{CH}_3$ signal.

^{13}C -n.m.r.(100MHz) $\delta(\text{CDCl}_3)$: 168.24, 165.31, 162.39
(-NCH(CH(CH $\underline{\text{C}}\text{H}_3$)CH $\underline{\text{C}}\text{H}_2\text{CH}_3$)CO $\underline{\text{C}}\text{O}_2\text{CH}_2\text{CH}_3$ and phthaloyl carbonyls), 145.12, 135.54, 133.66,
128.80, 127.28, 123.30 (aromatic carbons), 58.29
(-NHCH(CH(CH $\underline{\text{C}}\text{H}_3$)CH $\underline{\text{C}}\text{H}_2\text{CH}_3$)CO $\underline{\text{C}}\text{O}_2\text{CH}_2\text{CH}_3$), 57.79
(-NHCH(CH(CH $\underline{\text{C}}\text{H}_3$)CH $\underline{\text{C}}\text{H}_2\text{CH}_3$)CO $\underline{\text{C}}\text{O}_2\text{CH}_2\text{CH}_3$), 34.5 (-NHCH(CH(CH $\underline{\text{C}}\text{H}_3$)CH $\underline{\text{C}}\text{H}_2\text{CH}_3$)CO $\underline{\text{C}}\text{O}_2\text{CH}_2\text{CH}_3$),
25.88 (-NHCH(CH(CH $\underline{\text{C}}\text{H}_3$)CH $\underline{\text{C}}\text{H}_2\text{CH}_3$)CO $\underline{\text{C}}\text{O}_2\text{CH}_2\text{CH}_3$), 15.27, 14.02, 10.98
(-NHCH(CH(CH $\underline{\text{C}}\text{H}_3$)CH $\underline{\text{C}}\text{H}_2\text{CH}_3$)CO $\underline{\text{C}}\text{O}_2\text{CH}_2\text{CH}_3$, -NHCH(CH(CH $\underline{\text{C}}\text{H}_3$)CH $\underline{\text{C}}\text{H}_2\text{CH}_3$)CO $\underline{\text{C}}\text{O}_2\text{CH}_2\text{CH}_3$ and
-NHCH(CH(CH $\underline{\text{C}}\text{H}_3$)CH $\underline{\text{C}}\text{H}_2\text{CH}_3$)CO $\underline{\text{C}}\text{O}_2\text{CH}_2\text{CH}_3$).

Note: The signals at 168.24, 165.31 and 162.39 may be interchangeable. The signals at
15.27, 14.02 and 10.98 may also be interchangeable.

N-Phenylureido-L-alanine (11a)

Phenyl isocyanate (0.67g, 0.005mol) was added to a solution of L-alanine (0.5g, 0.005mol) in 1M sodium hydroxide (5ml). The reaction mixture was stirred for 3hr at room temperature and acidified with 10% hydrochloric acid. The precipitate was filtered, washed

with cold water and recrystallized from ethanol/water to yield *N*-phenylureido-L-alanine as fine white needles (330mg, 32%).

m.p. 164-166°C (uncorrected). Lit. 174°C.¹²¹

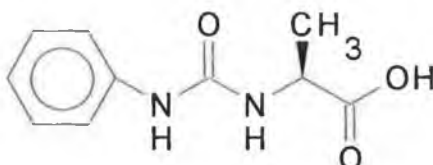

Spectroscopic analysis

i.r. ν_{\max} (KBr): 3400 (OH), 3225, 1700 (carboxylic acid C=O), 1625 (urea C=O), 1600, 1575, 1550, 1450, 1300 cm^{-1} .

^1H -n.m.r.(400MHz) δ (DMSO): 1.29 (3H, d, $J=7.4\text{Hz}$, $-\text{NCH}(\underline{\text{C}}\text{H}_3)\text{CO}_2\text{H}$), 4.12-4.19 (1H, m, $-\text{NHCH}(\underline{\text{C}}\text{H}_3)\text{CO}_2\text{H}$), 6.44 (1H, d, $J=7.4\text{Hz}$, $-\text{NHCH}(\underline{\text{C}}\text{H}_3)\text{CO}_2\text{H}$), 6.86-6.90 (1H, m, ArH 4), 7.18-7.22 (2H, m, ArH 3&5), 7.34-7.37 (2H, m, ArH 2&6), 8.6 (1H, s, PhNHCO-).

^{13}C -n.m.r.(100MHz) δ (DMSO): 174.93 ($-\text{NHCH}(\underline{\text{C}}\text{H}_3)\underline{\text{C}}\text{O}_2\text{H}$), 154.62 (PhNHCO-), 140.23, 128.73, 121.24, 117.57 (aromatic carbons), 47.97 ($-\text{NHCH}(\underline{\text{C}}\text{H}_3)\text{CO}_2\text{H}$), 18.28 ($-\text{NHCH}(\underline{\text{C}}\text{H}_3)\text{CO}_2\text{H}$).

N-Phenylureido-L-leucine (11b)

N-Phenylureido-L-leucine was furnished by the method described for *N*-phenylureido-L-alanine. Phenyl isocyanate (0.67g, 0.005mol) was added to a solution of L-leucine (0.5g, 0.004mol) in 1M sodium hydroxide (5ml). Recrystallization from ethanol/water yielded *N*-Phenylureido-L-leucine as fine white needles (280mg, 28%).

m.p. 108-110°C (uncorrected). Lit. 115°C.¹²¹

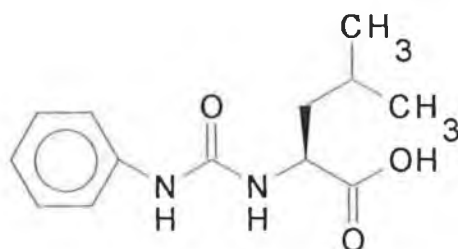

Spectroscopic analysis

i.r. ν_{\max} (KBr): 3400 (OH), 3350, 1725 (carboxylic acid C=O), 1650 (urea C=O), 1600, 1500, 1475, 1200, 1150 cm^{-1} .

^1H -n.m.r.(400MHz), δ (DMSO): 0.87-0.91(6H, d, $J=6.9\text{Hz}$, $-\text{NHCH}(\text{CH}_2\text{CH}(\text{CH}_3)_2)\text{CO}_2\text{H}$), 1.44-1.56 (2H, m, $-\text{NHCH}(\text{CH}_2\text{CH}(\text{CH}_3)\text{CO}_2\text{H})$), 1.62-1.72 (1H, m, $-\text{NHCH}(\text{CH}_2\text{CH}(\text{CH}_3)_2)\text{CO}_2\text{H}$), 4.13-4.19 (1H, m, $-\text{NHCH}(\text{CH}_2\text{CH}(\text{CH}_3)_2)\text{CO}_2\text{H}$), 6.37-6.38 (1H, d, $J=8.4\text{Hz}$, $-\text{NHCH}(\text{CH}_2\text{CH}(\text{CH}_3)_2)\text{CO}_2\text{H}$), 6.86-6.90 (1H, m, ArH 4), 7.18-7.22 (2H, m, ArH 3&5), 7.34-7.39 (2H, m, ArH 2&6), 8.54 (1H, s, PhNHCO-).

^{13}C -n.m.r.(100) δ (DMSO): 174.93 ($-\text{NHCH}(\text{CH}_2\text{CH}(\text{CH}_3)_2)\text{CO}_2\text{H}$), 154.84 (PhNHCO-), 140.19, 128.72, 121.21, 117.50 (aromatic carbons), 50.65 ($-\text{NHCH}(\text{CH}_2\text{CH}(\text{CH}_3)_2)\text{CO}_2\text{H}$), 40.92 ($-\text{NHCH}(\text{CH}_2\text{CH}(\text{CH}_3)_2)\text{CO}_2\text{H}$), 24.40 ($-\text{NHCH}(\text{CH}_2\text{CH}(\text{CH}_3)_2)\text{CO}_2\text{H}$), 22.85, 21.60 ($-\text{NHCH}(\text{CH}_2\text{CH}(\text{CH}_3)_2)\text{CO}_2\text{H}$)

N-Phenylureido-L-isoleucine (11c)

N-Phenylureido-L-isoleucine was afforded by the procedure described for compound *N*-phenylureido-L-alanine. Phenyl isocyanate (0.67g, 0.005mol) was added to a solution of L-isoleucine (0.5g, 0.004mol) in 1M sodium hydroxide (5ml). Recrystallisation from ethanol/water furnished *N*-phenylureido-L-isoleucine as fine white needles (210mg, 21%).
m.p 110-112°C (uncorrected). Lit. 120°C.¹²¹

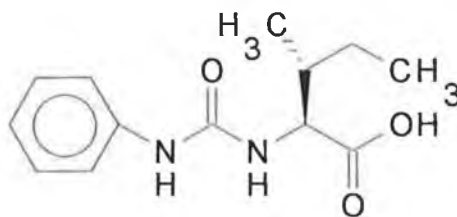

Spectroscopic analysis

i.r. ν_{\max} (KBr): 3400 (OH), 1700 (carboxylic acid C=O), 1675 (urea C=O), 1600, 1575, 1200 cm^{-1} .

¹H-n.m.r.(400MHz) δ (DMSO): 0.85-0.89 (6H, m, -NHCH(CH(CH₃)CH₂CH₃)CO₂H and -NHCH(CH(CH₃)CH₂CH₃)CO₂H), 1.09-1.20 (1H, m, -NHCH(CH(CH₃)CH₂CH₃)CO₂H), 1.35-1.45 (1H, m, -NHCH(CH(CH₃)CH₂CH₃)CO₂H), 1.76-1.82 (1H, m, -NHCH(CH(CH₃)CH₂CH₃)CO₂H), 4.10-4.14 (1H, dd, $J_A=8.7\text{Hz}$, $J_B=4.4\text{Hz}$, -NHCH(CH(CH₃)CH₂CH₃)CO₂H), 6.43 (1H, d, $J=8.7\text{Hz}$, -NHCH(CH(CH₃)CH₂CH₃)CO₂H), 6.87 (1H, t, $J=7.38\text{Hz}$, ArH 4), 7.20 (2H, t, $J=7.38\text{Hz}$, ArH 3&5), 7.34-7.37 (2H, m, ArH 2&6), 8.66 (1H, s, PhNHCO-).

^{13}C -n.m.r.(100MHz) δ (DMSO): 175.00 (-NHCH(CH(CH₃)CH₂CH₃)CO₂H), 154.93 (PhNHCO-), 140.31, 128.72, 121.10, 117.38 (aromatic carbons), 56.58 (-NHCH(CH(CH₃)CH₂CH₃)CO₂H), 37.10 (-NHCH(CH(CH₃)CH₂CH₃)CO₂H), 24.65 (-NHCH(CH(CH₃)CH₂CH₃)CO₂H), 15.77, 11.58 (-NHCH(CH(CH₃)CH₂CH₃)CO₂H and -NHCH(CH(CH₃)CH₂CH₃)CO₂H)

Note: The signals at 15.77 and 11.58 may be interchangeable.

N-Chloroacetyl glycine (12a)

Chloroacetyl chloride (2.26g, 0.02mol) was added to a stirred suspension of glycine (0.75g, 0.01mol) in dry ethyl acetate (50ml) and gently heated under reflux for 4hr under anhydrous conditions. The unreacted glycine was filtered off, and the solvent and excess chloroacetyl chloride were removed from the filtrate. *in vacuo*. The resulting oil was washed with diethyl ether (3x20ml) to give *N*-chloroacetyl glycine as an off-white solid. m.p. 94-96°C (uncorrected) Lit 100°C.¹³⁵

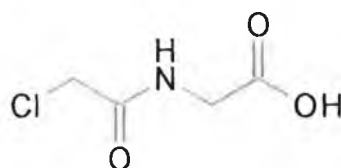

Spectroscopic analysis

i.r. ν_{max} (KBr): 3300 (OH), 1725 (carboxylic acid C=O), 1650 (amide C=O), 1550, 1450, 1350 cm^{-1} .

^1H -n.m.r.(400MHz) δ (DMSO): 3.78 (2H, d, J=5.8Hz, -NHCH₂CO₂H), 4.12 (2H, s, ClCH₂CO-), 8.54 (1H, t, J=5.7Hz, -NH).

^{13}C -n.m.r.(100MHz) δ (DMSO): 170.96 (-NHCH $\underline{\text{C}}\text{O}_2\text{H}$), 166.46 (ClCH $\underline{\text{C}}\text{O}$ -), 42.40 (-NHCH $\underline{\text{C}}\text{O}_2\text{H}$), 40.01 (ClCH $\underline{\text{C}}\text{O}$ -).

Preparation of N-chloroacetyl-L-leucine (12b)

Chloroacetyl chloride (2.26g, 0.02mol) was added to a stirred suspension of L-leucine (1.31g, 0.01mol) in dry ethyl acetate (50ml) and gently refluxed for 1hr under anhydrous conditions. The unreacted L-leucine was filtered off and the solvent and excess chloroacetyl chloride were removed from the filtrate *in vacuo*. The resulting oil was crystallised with chloroform/*n*-hexane to yield N-chloroacetyl-L-leucine as fine white crystals (1.21g, 58.4%). m.p. 130-132°C (uncorrected) Lit 136°C.¹³⁵

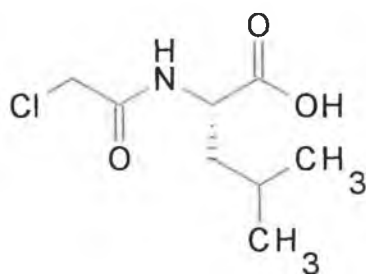

Spectroscopic analysis

i.r. ν_{max} (KBr): 3300 (OH), 1700 (carboxylic acid C=O), 1650 (amide C=O), 1550, 1225 cm^{-1} .

^1H -n.m.r.(400MHz) δ (DMSO): 0.82-0.88 (6H, d, $J=6.4\text{Hz}$, -NHCH(CH $\underline{\text{C}}\text{H}_2\text{CH}(\underline{\text{C}}\text{H}_3)_2\text{CO}_2\text{H}$), 1.46-1.64 (3H, m, -NHCH(CH $\underline{\text{C}}\text{H}_2\text{CH}(\underline{\text{C}}\text{H}_3)_2\text{CO}_2\text{H}$, and -NHCH(CH $\underline{\text{C}}\text{H}_2\text{CH}(\underline{\text{C}}\text{H}_3)_2\text{CO}_2\text{H}$), 4.08 (2H, s, ClCH $\underline{\text{C}}\text{O}$ -), 4.18-4.24 (1H, m, -NHCH(CH $\underline{\text{C}}\text{H}_2\text{CH}(\underline{\text{C}}\text{H}_3)_2\text{CO}_2\text{H}$), 8.48 (1H, d, $J=7.9\text{Hz}$, -NH).

^{13}C -n.m.r.(100MHz) δ (DMSO): 173.67 (-NHCH(CH₂CH(CH₃)₂)CO₂H) 165.99 (ClCH₂CO-), 50.92 (ClCH₂CO-), 42.40 (-NHCH(CH₂CH(CH₃)₂)CO₂H), 40.01 (-NHCH(CH₂CH(CH₃)₂)CO₂H), 24.33 (-NHCH(CH₂CH(CH₃)₂)CO₂H), 22.86, 21.30 (-NHCH(CH₂CH(CH₃)₂)CO₂H).

N-Chloroacetyl-L-leucine methyl ester (12c)

Thionyl chloride (0.6g, 0.005mol) was added to methanol (20ml) at 0°C. *N*-Chloroacetyl-L-leucine (1g, 0.005mol) was added in portions and the temperature was slowly raised to 40°C. The reaction mixture was stirred for 4hr at 40°C and the excess solvent removed *in vacuo*. The resulting yellow oil was dissolved in ethyl acetate and washed with water (3x20ml). The organic layer was dried with magnesium sulphate, and the solvent removed *in vacuo* to give *N*-chloroacetyl-L-leucine methyl ester as a colourless oil (358mg, 32.3%).

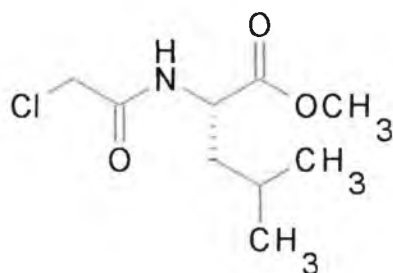

Spectroscopic analysis

i.r. ν_{max} (CHCl₃): 3302 (NH), 2961, 1751 (ester C=O), 1673 (amide C=O), 1545, 1438, 1374, 1210cm⁻¹.

^1H -n.m.r.(400MHz) δ (CDCl_3): 0.87 (6H, d, $J=5.9\text{Hz}$, $-\text{NHCH}(\text{CH}_2\text{CH}(\text{CH}_3)_2)\text{CO}_2\text{CH}_3$), 1.51-1.64 (3H, m, $-\text{NHCH}(\text{CH}_2\text{CH}(\text{CH}_3)_2)\text{CO}_2\text{CH}_3$ and $-\text{NHCH}(\text{CH}_2\text{CH}(\text{CH}_3)_2)\text{CO}_2\text{CH}_3$), 3.68 (3H, s, $-\text{NHCH}(\text{CH}_2\text{CH}(\text{CH}_3)\text{CO}_2\text{CH}_3)$), 4.01 (2H, s, $\text{ClCH}_2\text{CO}-$), 4.56 (1H, m, $-\text{NHCH}(\text{CH}(\text{CH}_2\text{CH}(\text{CH}_3)_2)\text{CO}_2\text{CH}_3)$), 6.95 (1H, d, $J=8.4\text{Hz}$, $-\text{NH}$).

^{13}C -n.m.r.(100MHz) δ (CDCl_3): 172.66 ($-\text{NHCH}(\text{CH}_2\text{CH}(\text{CH}_3)_2)\text{CO}_2\text{CH}_3$), 165.82 ($\text{ClCH}_2\text{CO}-$), 52.33 ($-\text{NHCH}(\text{CH}_2\text{CH}(\text{CH}_3)\text{CO}_2\text{CH}_3)$), 50.88 ($\text{ClCH}_2\text{CO}-$), 42.28 ($-\text{NHCH}(\text{CH}_2\text{CH}(\text{CH}_3)_2)\text{CO}_2\text{CH}_3$), 41.10 ($-\text{NHCH}(\text{CH}_2\text{CH}(\text{CH}_3)_2)\text{CO}_2\text{CH}_3$), 24.69 ($-\text{NHCH}(\text{CH}_2\text{CH}(\text{CH}_3)_2)\text{CO}_2\text{CH}_3$), 22.65, 21.71 ($-\text{NHCH}(\text{CH}_2\text{CH}(\text{CH}_3)_2)\text{CO}_2\text{CH}_3$).

***N*-Chloroacetyl-L-leucine ethyl ester (12d)**

Thionyl chloride (0.6g, 0.005mol) was added to ethanol (20ml) at 0°C . *N*-Chloroacetyl-L-leucine (1g, 0.005mol) was added in portions and the temperature was slowly raised to 40°C . The reaction mixture was stirred for 4hr at 40°C and the excess ethanol removed *in vacuo*. The resulting yellow oil was dissolved in ethyl acetate and washed with water (3x20ml). The organic layer was dried with magnesium sulphate, and the solvent removed *in vacuo* to give *N*-chloroacetyl-L-leucine ethyl ester as a colourless oil (332mg, 28.2%).

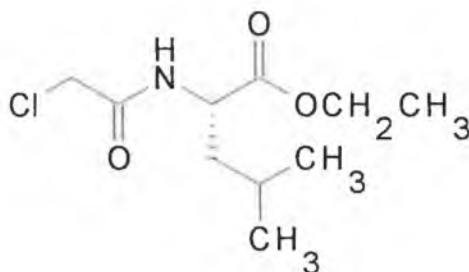

Spectroscopic analysis

i.r. ν_{\max} (CHCl₃): 3300 (NH), 2950, 1750 (ester C=O), 1650 (amide C=O), 1550, 1200cm⁻¹.

¹H-n.m.r.(400MHz) δ (CDCl₃): 0.84 (6H, d, J=5.44Hz, -NHCH(CH₂CH(CH₃)₂)CO₂CH₂CH₃), 1.18 (3H, t, J=7.1Hz -NHCH(CH₂CH(CH₃)₂)CO₂CH₂CH₃), 1.47-1.59 (3H, m, -NHCH(CH₂CH(CH₃)₂)CO₂CH₂CH₃ and -NHCH(CH₂CH(CH₃)CO₂CH₂CH₃), 3.97 (2H, s, ClCH₂CO-), 4.09 (2H, q, J=7.1Hz, -NHCH(CH₂CH(CH₃)₂)CO₂CH₂CH₃), 4.50 (1H, m, -NHCH(CH₂CH(CH₃)₂)CO₂CH₂CH₃), 7.00 (1H, d, J=7.88Hz, -NH).

¹³C-n.m.r.(100MHz) δ (CDCl₃): 172.12 (-NHCH(CH₂CH(CH₃)₂)CO₂CH₂CH₃), 165.73 (-ClCH₂CO-), 61.28 (-NHCH(CH₂CH(CH₃)₂)CO₂CH₂CH₃), 50.86 (ClCH₂CO-), 42.20 (-NHCH(CH₂CH(CH₃)₂)CO₂CH₂CH₃), 41.05 (-NHCH(CH₂CH(CH₃)₂)CO₂CH₂CH₃), 24.59 (-NHCH(CH₂CH(CH₃)₂)CO₂CH₂CH₃), 22.54, 21.64 (-NHCH(CH₂CH(CH₃)₂)CO₂CH₂CH₃), 13.88 (-NHCH(CH₂CH(CH₃)₂)CO₂CH₂CH₃).

N-Chloroacetyl-D-leucine (12e)

Chloroacetyl chloride (2.26g, 0.02mol) was added to a stirred suspension of D-leucine (1.31g, 0.01mol), in dry ethyl acetate (50ml), and gently refluxed for 1hr under anhydrous conditions. The unreacted D-leucine was filtered off, and the solvent and excess chloroacetyl chloride were removed from the filtrate. *in vacuo*. Recrystallisation of the resulting oil with chloroform/*n*-hexane, furnished *N*-chloroacetyl-D-leucine as fine white crystals (1.1g, 52.5%). m.p. 128-132°C (uncorrected). Lit. 136°C.¹³⁵

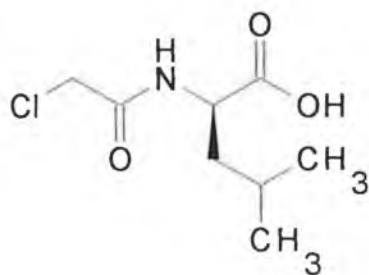

Spectroscopic analysis

i.r. ν_{\max} (KBr): 3324 (OH), 1721 (carboxylic acid C=O), 1640 (amide C=O), 1558, 1239 cm^{-1} .

^1H -n.m.r.(400MHz) δ (CDCl_3): 0.98 (6H, d, $J=4.92\text{Hz}$, $-\text{NHCH}(\text{CH}_2\text{CH}(\text{CH}_3)_2)\text{CO}_2\text{H}$), 1.62-1.79 (3H, m, $-\text{NHCH}(\text{CH}_2\text{CH}(\text{CH}_3)_2)\text{CO}_2\text{H}$ and $-\text{NHCH}(\text{CH}_2\text{CH}(\text{CH}_3)_2)\text{CO}_2\text{H}$), 4.11 (2H, s, $\text{ClCH}_2\text{CO}-$) 4.61-4.67 (1H, m, $-\text{NHCH}(\text{CH}_2\text{CH}(\text{CH}_3)_2)\text{CO}_2\text{H}$), 6.95 (1H, d, $J=8.4\text{Hz}$, $-\text{NH}$).

^{13}C -n.m.r.(100MHz) δ (DMSO): 176.53 ($-\text{NHCH}(\text{CH}_2\text{CH}(\text{CH}_3)_2)\text{CO}_2\text{H}$), 166.36 ($\text{ClCH}_2\text{CO}-$), 51.00 ($\text{ClCH}_2\text{CO}-$), 42.38 ($-\text{NHCH}(\text{CH}_2\text{CH}(\text{CH}_3)_2)\text{CO}_2\text{H}$), 40.97 ($-\text{NHCH}(\text{CH}_2\text{CH}(\text{CH}_3)_2)\text{CO}_2\text{H}$), 24.88, 22.78 ($-\text{NHCH}(\text{CH}_2\text{CH}(\text{CH}_3)_2)\text{CO}_2\text{H}$), 21.79 ($-\text{NHCH}(\text{CH}_2\text{CH}(\text{CH}_3)_2)\text{CO}_2\text{H}$).

N-(2-trimethylammonium-acetyl)-L-leucine chloride (13)

N-Chloroacetyl L-leucine (2g, 0.01mol) was added to a solution of trimethylamine (25%, 4ml). The reaction mixture was stirred for 2hr at 45°C and the water and unreacted trimethylamine removed *in vacuo*. The resulting oil was triturated with chloroform and the

precipitate filtered to give the title compound as a white crystalline solid (760mg,24.6%).

m.p. 212-216°C. Lit. 219°C.¹⁴⁷

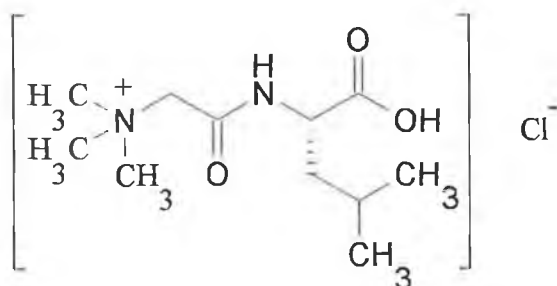

Spectroscopic analysis

i.r. ν_{\max} (KBr): 3450 (OH), 2950, 1727 (carboxylic acid C=O), 1678 (amide C=O), 1552, 1488, 1274, 1237, 1210 cm^{-1} .

^1H -n.m.r.(400MHz) δ (DMSO) : 0.91-0.96 (6H, d, $J=5.9\text{Hz}$, $-\text{NHCH}(\text{CH}_2\text{CH}(\text{CH}_3)_2\text{CO}_2\text{H})$), 1.69-1.74 (3H, m, $-\text{NHCH}(\text{CH}_2\text{CH}(\text{CH}_3)_2\text{CO}_2\text{H})$ and $-\text{NHCH}(\text{CH}_2\text{CH}(\text{CH}_3)_2\text{CO}_2\text{H})$), 3.33 (9H, s, $(\text{H}_3\text{C})_3\text{NCH}_2\text{CO}-$), 4.18 (2H, s, $(\text{H}_3\text{C})_3\text{NCH}_2\text{CO}-$), 4.43 (1H, m, $-\text{NHCH}(\text{CH}_2\text{CH}(\text{CH}_3)_2\text{CO}_2\text{H})$), 5.02 (1H, d, $J=8\text{Hz}$, $-\text{NH}$).

^{13}C -n.m.r.(100MHz) δ (DMSO): 173.24 ($-\text{NHCH}(\text{CH}_2\text{CH}(\text{CH}_3)_2\text{CO}_2\text{H})$), 163.49 ($(\text{H}_3\text{C})\text{NHCH}_2\text{CO}-$), 63.79 ($(\text{H}_3\text{C})\text{NHCH}_2\text{CO}-$), 53.24 ($(\text{H}_3\text{C})\text{NHCH}_2\text{CO}-$), 50.76 ($-\text{NHCH}(\text{CH}_2\text{CH}(\text{CH}_3)_2\text{CO}_2\text{H})$), 40.05 ($-\text{NHCH}(\text{CH}_2\text{CH}(\text{CH}_3)_2\text{CO}_2\text{H})$), 24.35 ($-\text{NHCH}(\text{CH}_2\text{CH}(\text{CH}_3)_2\text{CO}_2\text{H})$), 22.85, 21.16 ($-\text{NHCH}(\text{CH}_2\text{CH}(\text{CH}_3)_2\text{CO}_2\text{H})$).

CHAPTER FOUR

BIDENTATE LIGAND INHIBITORS

Introduction

Our initial studies into amino acid derivatives as potential inhibitors of the malarial aminopeptidase led us to believe that inhibitors with a similar structure to the *N*-cinnamoyl derivatives would make the best starting point for designing novel inhibitors of the malarial aminopeptidase. However because the attempted epoxidation of the vinylic group was unsuccessful due to the low electron density around the $-C=C-$ bond, we were unable to incorporate functionalities into the backbone of the molecules which could chelate the active site metal resulting in a potent inhibitor. It was then decided to prepare some simple aromatic carboxylic acids with functional groups α to the carboxyl which could complex with the active site metal. This would then be coupled to an amine and the resulting molecule could form a bidentate ligand which could chelate the active site metal via the amide carbonyl and the functional group α to it (fig. 4.1) in a similar manner to the model proposed for bestatin by Nishino and Powers.¹¹⁷ It was hoped that these molecules would be potent inhibitors of the malarial aminopeptidase.

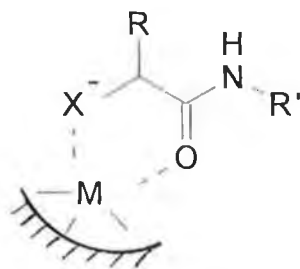

Fig. 4.1 Proposed binding of bidentate ligand inhibitors to active site metal.

All of the aromatic carboxylic acids were coupled to the same five amines, namely glycine, *L*-alanine, *L*-leucine, *L*-phenylalanine and phenethylamine (fig.4.2). This yielded a battery of results which were directly comparable and furnished information on the substrate specificity of the malarial aminopeptidase. It is known that the malarial aminopeptidase has a preference for amino acids with hydrophobic alkyl side chains such

as L-alanine and L-leucine.²⁰ These could be compared to glycine which has no side chain and L-phenylalanine which has a hydrophobic aryl side chain. Phenethylamine was chosen because of its similarity to the side chain of L-phenylalanine. A comparison of activity of inhibitors bearing these two amines would provide information on the importance of a carboxylic acid group in binding to the active site of the enzyme.

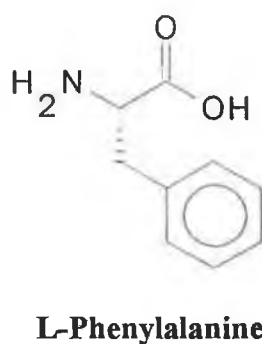
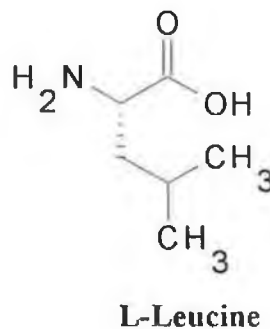
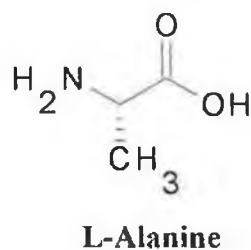
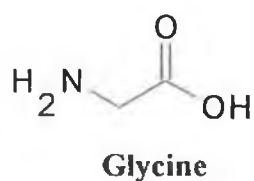
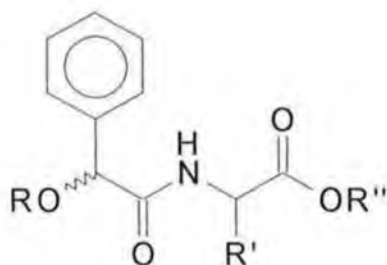

Fig. 4.2

4.1 N-2-Hydroxy-2-phenylacetyl derivatives



16a $R=COCH_3$, $R'=H$, $R''=CH_3$

16b $R=COCH_3$, $R'=(S)\text{-}CH_3$, $R''=CH_3$

16c $R=COCH_3$, $R'=(S)\text{-}CH_2CH(CH_3)_2$, $R''=CH_3$

16d $R=COCH_3$, $R'=(S)\text{-}CH_2Ph$, $R''=CH_3$

17a $R=H$, $R'=H$, $R''=H$

17b $R=H$, $R'=(S)\text{-}CH_2CH(CH_3)_2$, $R''=H$

17c $R=H$, $R'=(S)\text{-}CH_2Ph$, $R''=H$

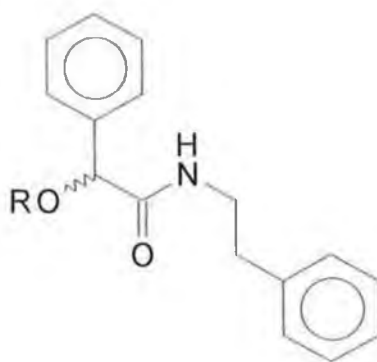

16e $R=COCH_3$

17d $R=H$

It was decided to prepare the *N*-2-hydroxy-2-phenylacetyl derivatives (**17**) because the starting material, mandelic acid (**14**) was cheap and freely available. It was hoped that the molecule would act as a bidentate ligand, which would chelate the active site metal *via* the hydroxyl and amide carbonyl (fig. 4.3). The phenyl group could interact favourably with the hydrophobic pocket S_1 . The binding site terminology of Berger and Schechter¹⁴⁸ is used in which the carboxyl side of the scissile bond is termed the P_1 residue and its corresponding subsite is called S_1 .

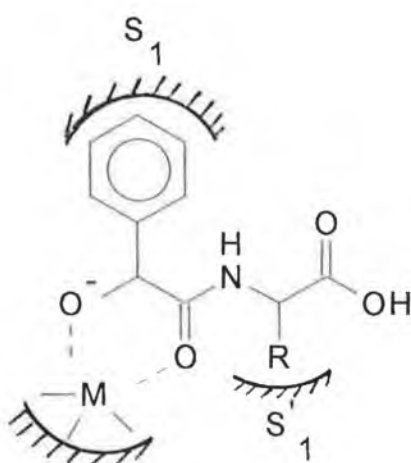
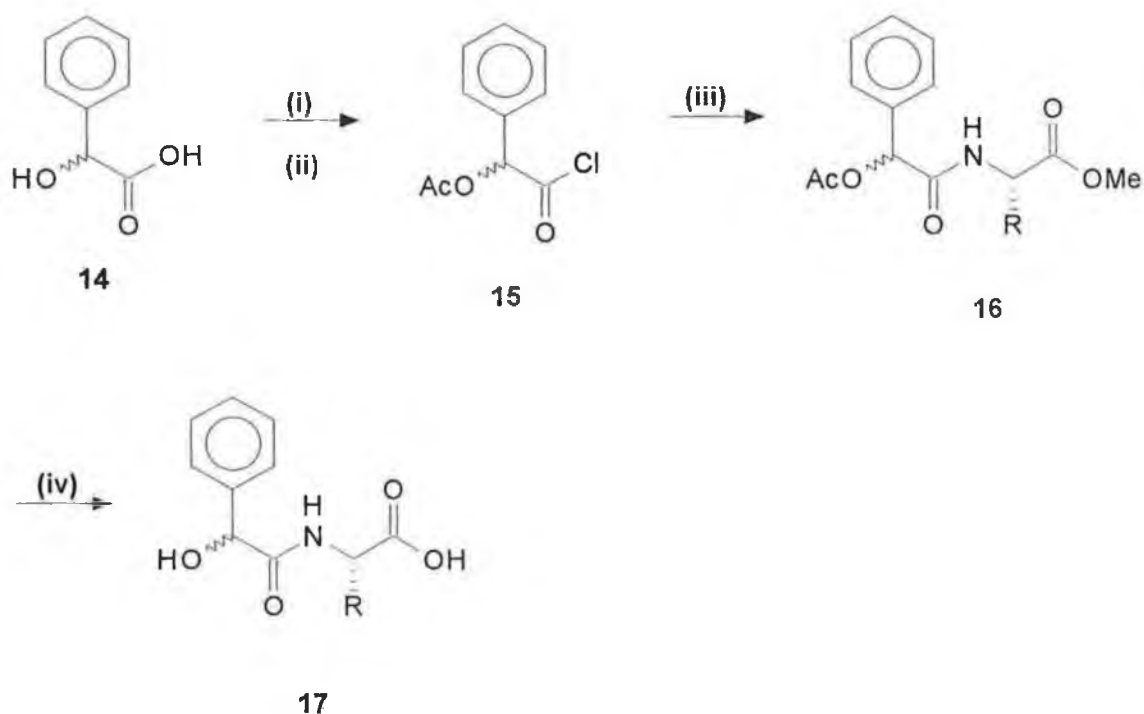

Fig. 4.3 Proposed binding of *N*-2-hydroxy-2-phenylacetyl amino acid to active site metal.

The hydroxy group of the mandelic acid was protected as the acetate by treatment with acetyl chloride.¹⁴⁹ This was then coupled with the amino acid methyl ester hydrochloride to yield the 2-acetoxy-2-phenylacetyl amino acid ester (**16**). Subsequent removal of the acetate and methyl ester protecting groups by base catalysed hydrolysis yielded the *N*-2-hydroxy-2-phenylacetyl derivatives (**17**) (scheme II). Because formation of the acetyl mandelyl chloride (**15**) strongly activated the 2-acetoxy-2-phenylacetic acid and would cause racemization of the chiral centre, it was decided to use *D/L*-mandelic acid (**14**) as the starting product rather than an enantiomerically pure form of the acid. This gave us a mixture of diastereomers in the final product (except for glycine and phenethylamine) which we could separate if the racemate showed high inhibitory activity. It was suspected that the 2(*S*)-hydroxy derivative would be the stronger inhibitor by analogy with bestatin.¹¹⁶

It should be noted, that because of their large number of hydrophilic substituents it may be difficult for these inhibitors to traverse the cell membrane. Hence we also tested the precursors of these molecules (**16**) in which the hydroxy group was protected as the acetate and the carboxylic acid functionality was protected as the methyl ester. These derivatives should be better able to interact more favourably with the lipophilic membranes thus allowing improved transport into the cell. Once inside the cell hydrolysis of these esters should yield the active forms of the inhibitors.

Scheme II



(i) AcCl

(ii) SOCl₂

(iii) Amino acid methyl ester hydrochloride, Et₃N, DCM

(iv) 1M NaOH, MeOH

The i.r. spectra of the *N*-2-acetoxy-2-phenylacetyl derivatives (**16a-e**) show an NH stretch in the high frequency region at 3350cm^{-1} . Peaks at 1740cm^{-1} and 1660cm^{-1} correspond to ester and amide carbonyls respectively. Absorptions in the aromatic region are also noted. The ^1H -n.m.r. spectra has a complex multiplet from δ 7.24-7.40 which integrates as 10 protons due to the aromatic protons. A multiplet in the range δ 6.5-6.7 which integrates as two protons is due to the amide protons. Two singlets due to the two diastereomeric protons on the carbon attached to the acetoxy group which integrate as one proton each occur at δ 6.08 and δ 6.11. Two singlets are observed in the range δ 3.72-3.74 which together integrate as six protons corresponding to the methyl ester protons of the two diastereomers. Two singlets are also observed at δ 2.17 and δ 2.19 which integrate as three protons each are due to the diastereomeric acetate protons. The ^{13}C -n.m.r. spectra have three characteristic carbonyl signals at δ 173, 169.9 and 169.1 corresponding to the ester, acetate and amide carbonyl carbons. The signal due to the α -carbon of the 2-acetoxy-2-phenylacetyl moiety occurs at δ 75. Signals at δ 52 and δ 21 are due to the ester and acetate methyl carbons respectively.

Hydrolysis of the *N*-2-acetoxy-2-phenylacetyl derivatives with 1M NaOH^{124,125} yielded the *N*-2-hydroxy-2-phenylacetyl derivatives (**17a-d**). The L-alanine derivative could not be isolated in this manner even by using milder hydrolysis conditions.

The i.r. spectra of the *N*-2-hydroxy-2-phenylacetyl derivatives (**17a-d**) have a sharp NH stretching peak at 3350cm^{-1} and a broad OH stretching absorption at 3200cm^{-1} . A peak due to the ester carbonyl stretching is observed at 1720cm^{-1} and one due to the amide carbonyl at 1630cm^{-1} . Aromatic absorptions are also noted. The ^1H -n.m.r. spectra has a signal at δ 8.0 which integrates as two due to the amide protons. A complex multiplet from δ 7.24-7.44 which integrates as five protons is due to the aromatic hydrogens. A signal at δ 6.3 which consists of two broad doublets and which together integrate as one proton is due to the diastereomeric hydroxyl protons. Two singlets in the region δ 4.8-5.0 which again together integrate as two protons correspond to the α -protons of the hydroxy acid moiety. The ^{13}C -n.m.r. spectra has two carbonyl signals at δ 173 and δ 171 corresponding to the acid and amide carbonyl carbons. The signal due to the α -carbon of the 2-hydroxy-2-phenylacetyl moiety occurs at δ 73.

The molecular ion in the electron impact mass spectra appears very weak due to the instability of the α -hydroxy acid functionality which loses water under these conditions to give a signal at $[M-H_2O]^+$. The fragment at m/z 107 and at m/z 77 are due to the α -hydroxy acid moiety. Immonium ions characteristic of the amino acid present are also observed. The fragmentation patterns of the *N*-2-hydroxy-2-phenylacetyl derivatives are described in greater detail in Figs. 4.4-4.6.

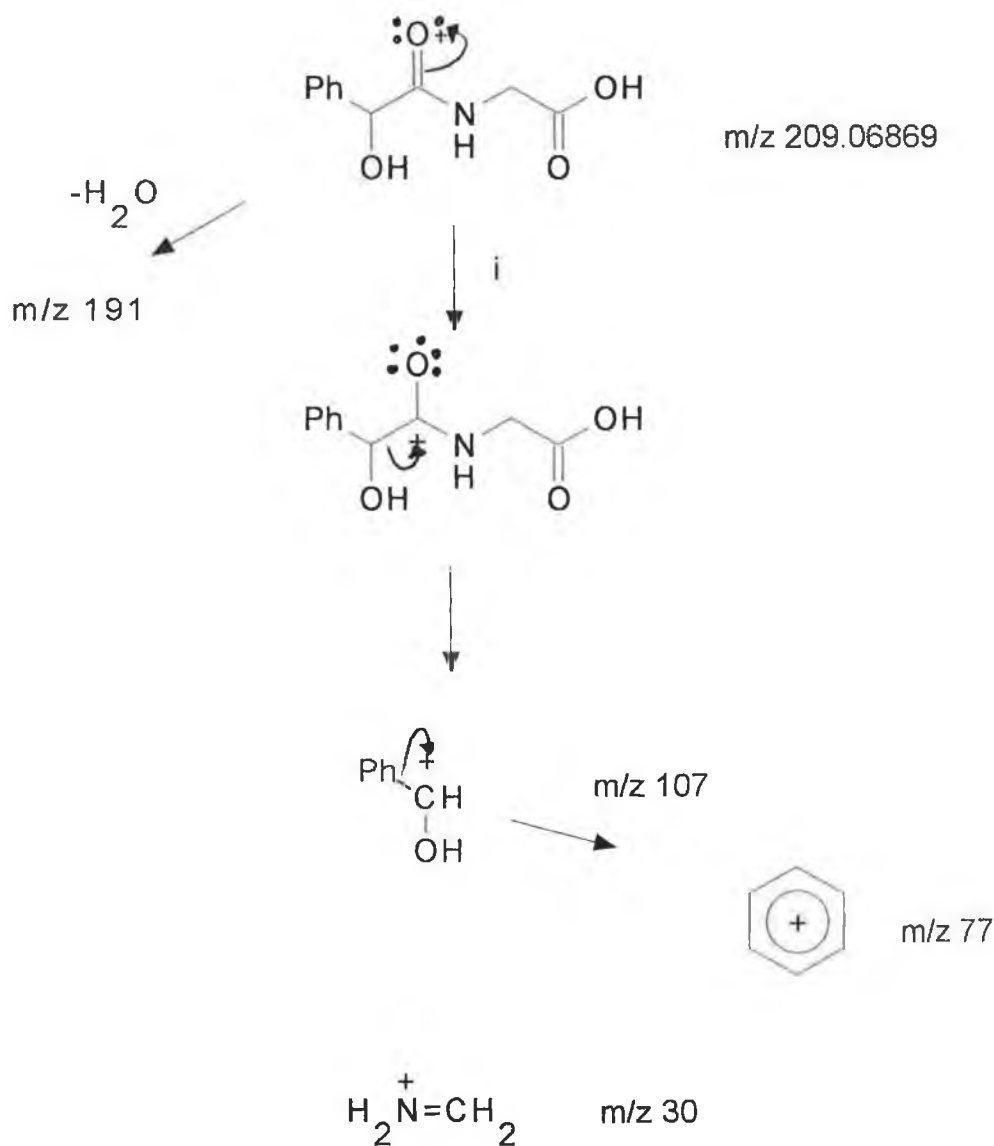

Fig. 4.4 EI fragmentation of *N*-2-hydroxy-2-phenylacetyl glycine (17a).

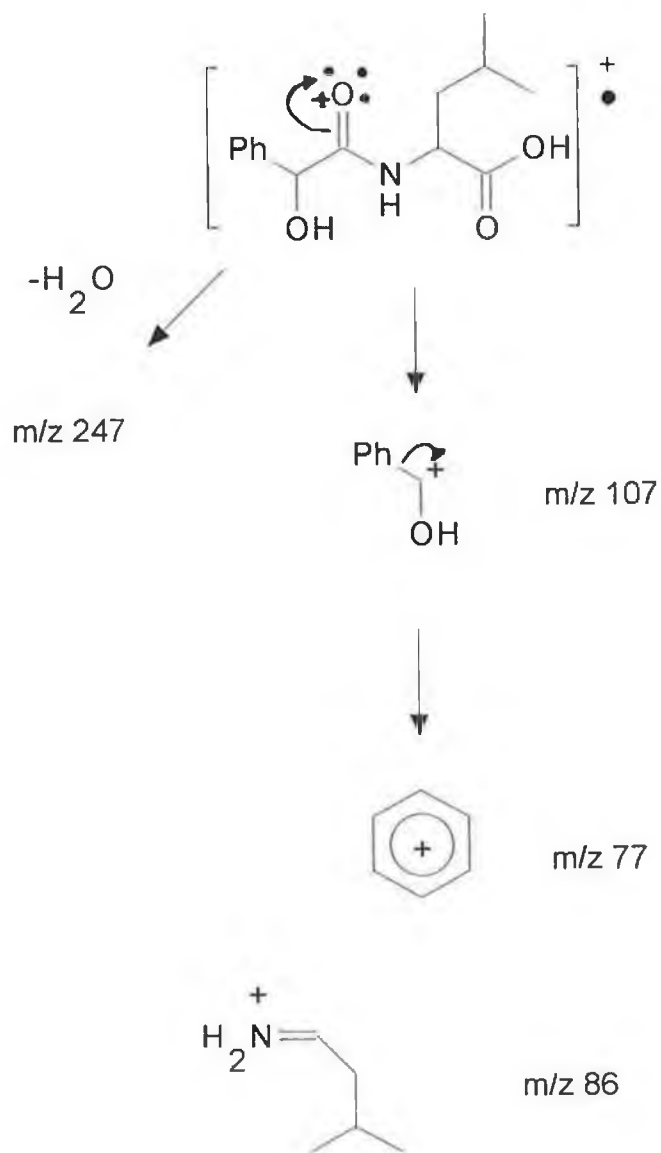

Fig. 4.5 EI fragmentation of *N*-2-hydroxy-2-phenylacetyl-L-leucine (17b).

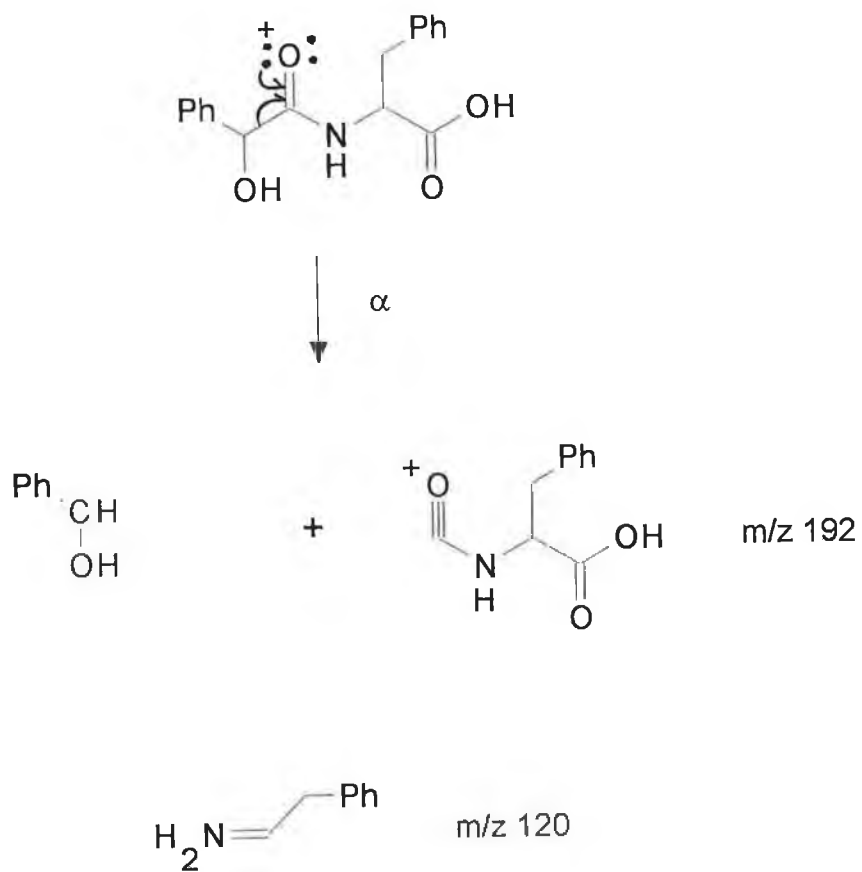
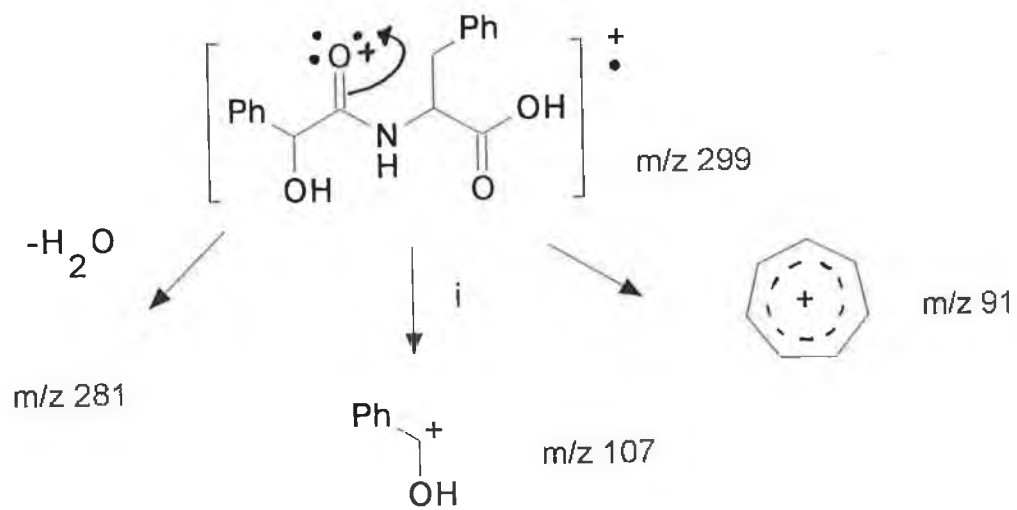

Fig. 4.6 EI fragmentation of *N*-2-hydroxy-2-phenylacetyl-L-phenylalanine (17c).

A crystal of *N*-((*R*)-2-hydroxy-2-phenylacetyl)-*L*-leucine was isolated from the diastereomeric mixture and examined by x-ray crystallography (fig. 4.7). Extensive hydrogen bonding is present in the crystal structure consisting of an intramolecular N-H \cdots O and intermolecular O-H \cdots O=C hydrogen bonds, as well as C-H \cdots O and sp^3 C-H \cdots π (arene) interactions.

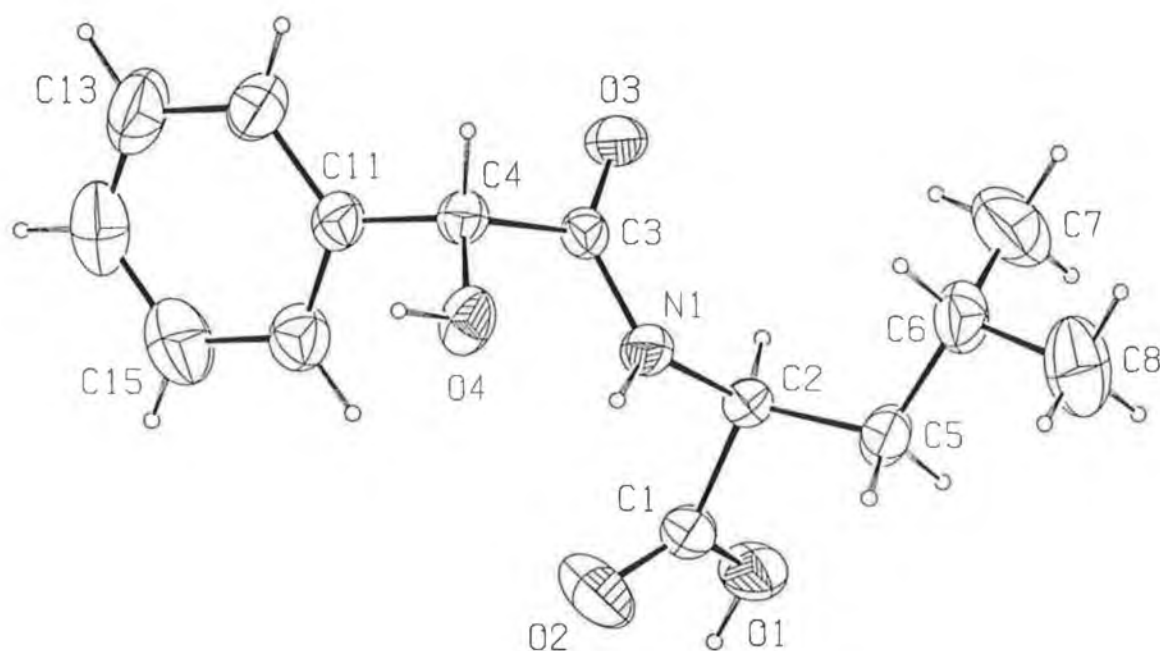
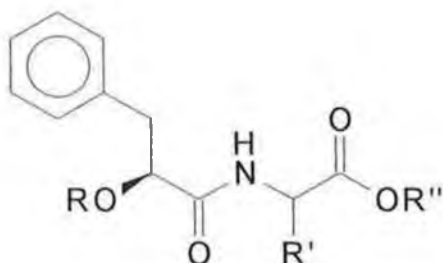

Fig. 4.7 Crystal structure of *N*-((*R*)-2-hydroxy-2-phenylacetyl)-*L*-leucine (17b).

4.2 N-2-Hydroxy-3-phenylpropionyl derivatives



20a R=COCH₃, R'=H, R''=CH₃

20b R=COCH₃, R'=(*S*)-CH₃, R''=CH₃

20c R=COCH₃, R'=(*S*)-CH₂CH(CH₃)₂, R''=CH₃

20d R=COCH₃, R'=(*S*)-CH₂Ph, R''=CH₃

21a R=H, R'=H, R''=H

21b R=H, R'=(*S*)-CH₃, R''=CH₃

21c R=H, R'=(*S*)-CH₂CH(CH₃)₂, R''=H

21d R=H, R'=(*S*)-CH₂Ph, R''=H

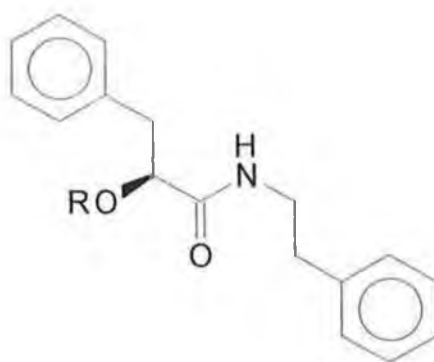

20e R=COCH₃

21e R=H

N-2-Hydroxy-3-phenylpropionyl derivatives were prepared to observe the effect of increasing the length of the carbon chain. It was hoped that the increased length of the aromatic side chain would allow the aromatic ring to interact more favourably with the hydrophobic pocket S_1 in the active site (fig. 4.8).

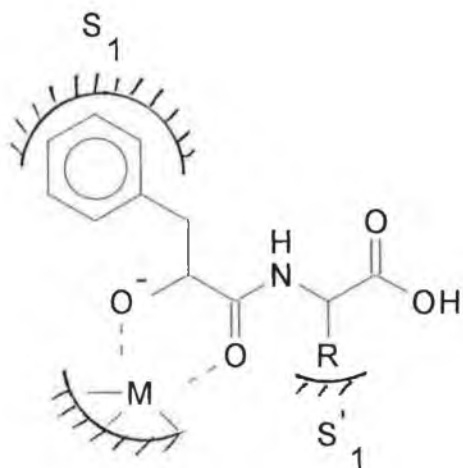
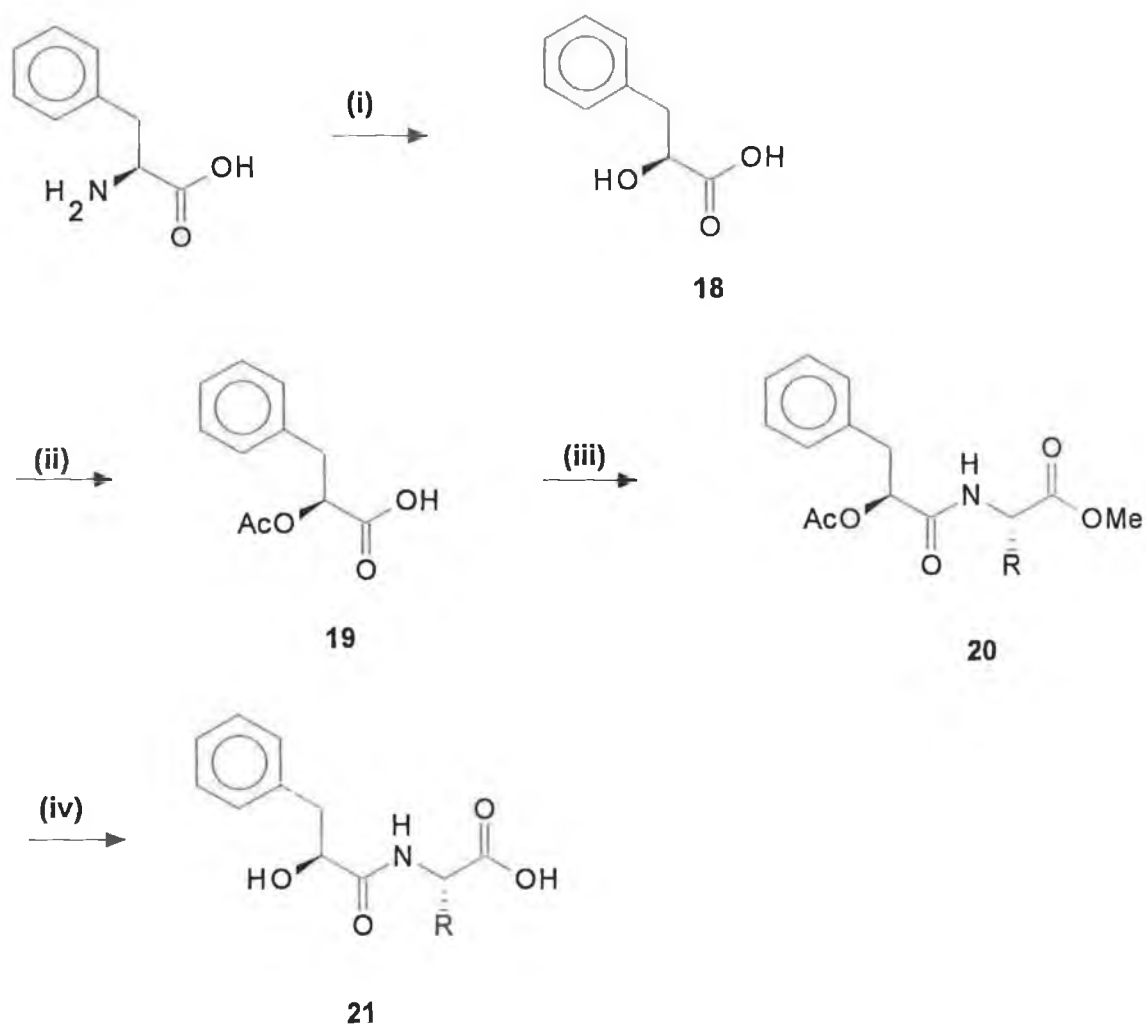

Fig. 4.8 Proposed binding of *N*-2-hydroxy-3-phenylpropionyl amino acid to active site metal.

The starting material L-phenyllactic acid (**18**) was prepared in an enantiomerically pure form via a diazotization of L-phenylalanine in acidic conditions.¹⁵⁰ L-phenyllactic acid is an inhibitor of the protease pepsin¹⁵¹ as well as yeast phenylalanine lyase.¹⁵² Attempts to prepare phenyllactic acid by forming the cyanohydrin of phenylacetaldehyde and subsequent acidic hydrolysis in a similar manner to that used for the synthesis of mandelic acid¹²¹ failed. This may be because some aldehydes do not form the bisulphite addition product readily.¹⁵³

By analogy to bestatin (fig. 2.14a) where the 2-(*S*)-hydroxy is essential for activity, L-phenyllactic acid (**18**) was chosen as the starting material in order to furnish a 2-(*S*)-hydroxy group in the final product. The hydroxyl group was protected as the acetate, and the resulting 2-acetoxy-3-phenylpropionic acid (**19**) was coupled to the amino acid methyl ester with DCCD^{123,124,132,133} to yield the *N*-2-acetoxy-3-phenylpropionyl amino acid ester derivative (**20**). Removal of the ester and acetate protecting groups by careful base hydrolysis^{124,125} yielded the *N*-2-hydroxy-3-phenylpropionyl amino acid derivatives (**21**) (Scheme III).

Scheme III



(i) NaNO_2 , 1M H_2SO_4

(ii) AcCl

(iii) Amino acid methyl ester hydrochloride, DCCD, Et_3N , DCM

(iv) 1M NaOH , MeOH

The i.r. spectra of the *N*-2-acetoxy-3-phenylpropionyl derivatives (**20a-e**) show characteristic NH peaks at 3300cm^{-1} . Peaks at 1750cm^{-1} and 1670cm^{-1} are due to the ester and amide functionalities respectively. Aromatic absorptions are also noted. The ^1H -n.m.r. spectra have a complex multiplet at δ 7.1-7.3 which integrates as five protons corresponding to the aromatic protons. The signal at δ 6.6 which integrates as one proton is due to the amide proton. A multiplet in the range δ 5.39-5.43 which integrates as one proton is due to the α -proton of the hydroxy acid moiety. The signal due to the benzylic methylene protons appears at δ 4.0 as two doublets which integrate as one proton each. Singlets at δ 2.1 and δ 3.1 which both integrate as three protons are due to the acetate and methyl ester protons respectively. The ^{13}C -n.m.r. spectra have three carbonyl signals in the region δ 169-173 corresponding to the ester, acetate and amide carbonyls. Four peaks are observed in the region δ 126-136 due to four non-equivalent aromatic carbons.

The i.r. spectra of the *N*-2-hydroxy-3-phenylpropionyl derivatives (**21a-e**) have a characteristic broad OH stretching peak at 3400cm^{-1} and an NH stretching peak at 3350cm^{-1} . Absorptions at 1730cm^{-1} and 1650cm^{-1} are due to the carboxylic acid and amide carbonyl stretches respectively. The ^1H -n.m.r. spectra has a signal at δ 8.0 which integrates as one proton due to the amide proton. A complex multiplet which integrates as five protons in the region δ 7.1-7.3 corresponds to the aromatic protons. A signal at δ 4.1 which integrates as one proton is due to the α -proton of the 2-hydroxy-3-phenylpropionyl moiety. Two pairs of doublets at δ 2.6 and δ 3.0 which integrate as one proton each are due to the benzylic protons. The unusual splitting is due to the adjacent chiral centre. The ^{13}C -n.m.r. spectra have two carbonyl signals at δ 171 and δ 173 due to the amide and carboxylic acid carbonyls. Four signals in the region δ 126-139 are due to the four non-equivalent aromatic carbons.

The electron impact mass spectra of the *N*-2-hydroxy-2-phenylpropionyl derivatives are similar to those of the *N*-2-hydroxy-2-phenylacetyl derivatives. The molecular ion again appears very weak due to the instability of the α -hydroxy acid functionality. The fragment at m/z 121 and at m/z 131 are due to the α -hydroxy acid moiety. Unlike the mass spectra of the *N*-2-hydroxy-2-phenylacetyl derivatives, a tropyllium ion is observed at m/z 91. This rearrangement is facilitated by the presence

of the methylene group of the 2-hydroxy-2-phenylpropionic acid moiety. Immonium ions characteristic of the amino acid present are also observed. The fragmentation patterns of the *N*-2-hydroxy-2-phenylpropionyl derivatives are described in greater detail in Figs. 4.9-4.11.

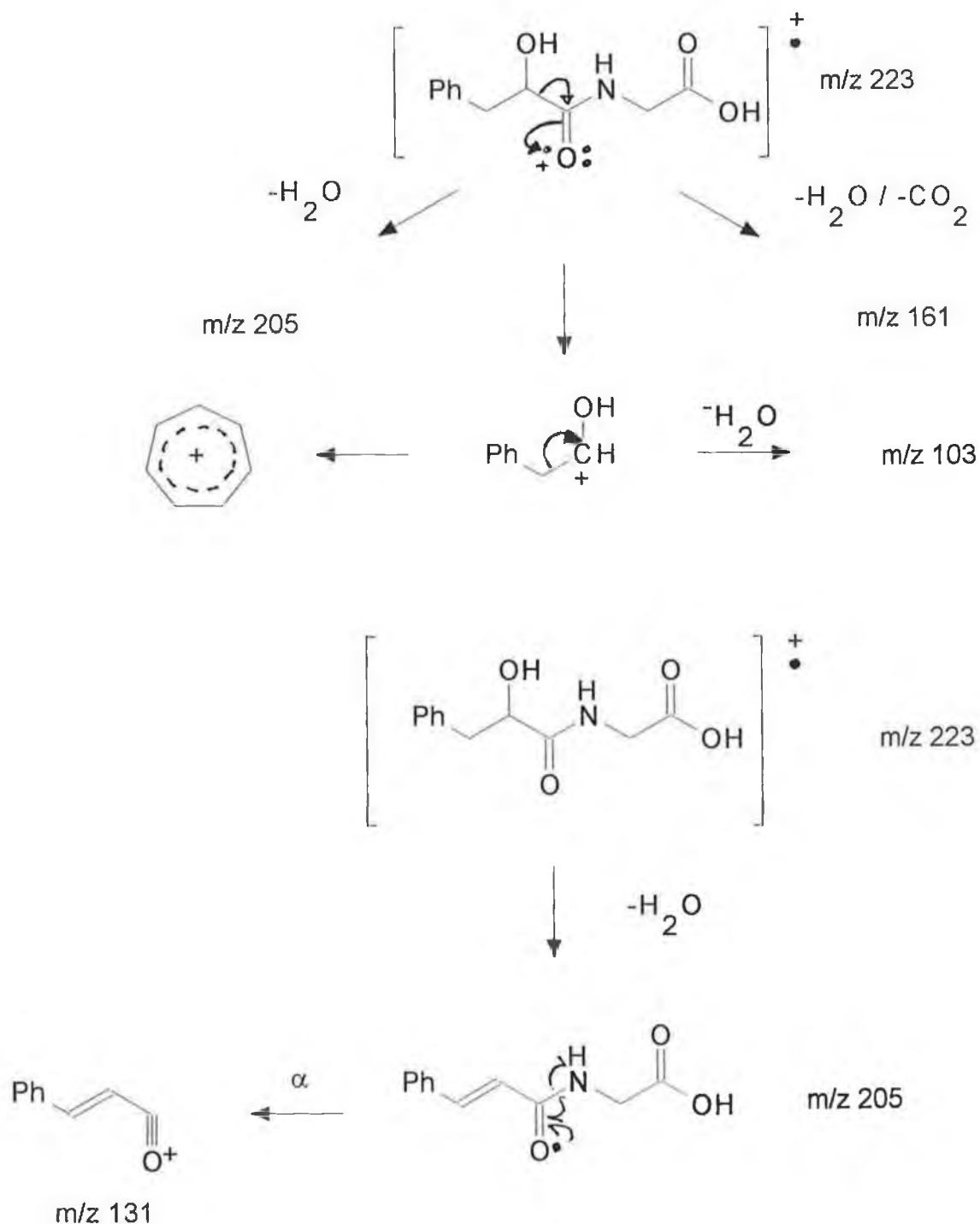

Fig. 4.9 EI fragmentation of *N*-2-hydroxy-3-phenylpropionyl glycine (21a).

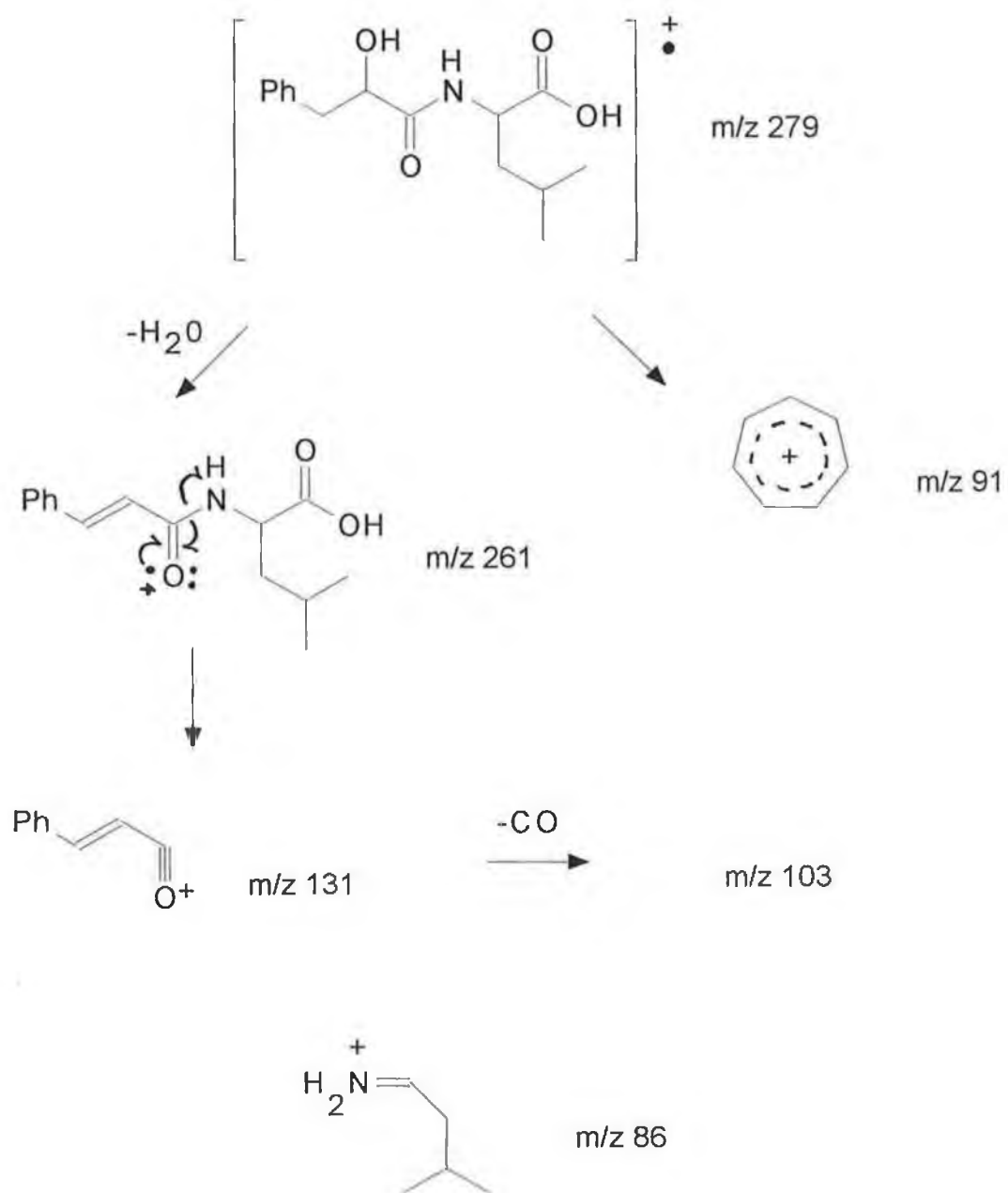

Fig. 4.10 EI fragmentation of *N*-2-hydroxy-3-phenylpropionyl-L-leucine (21c).

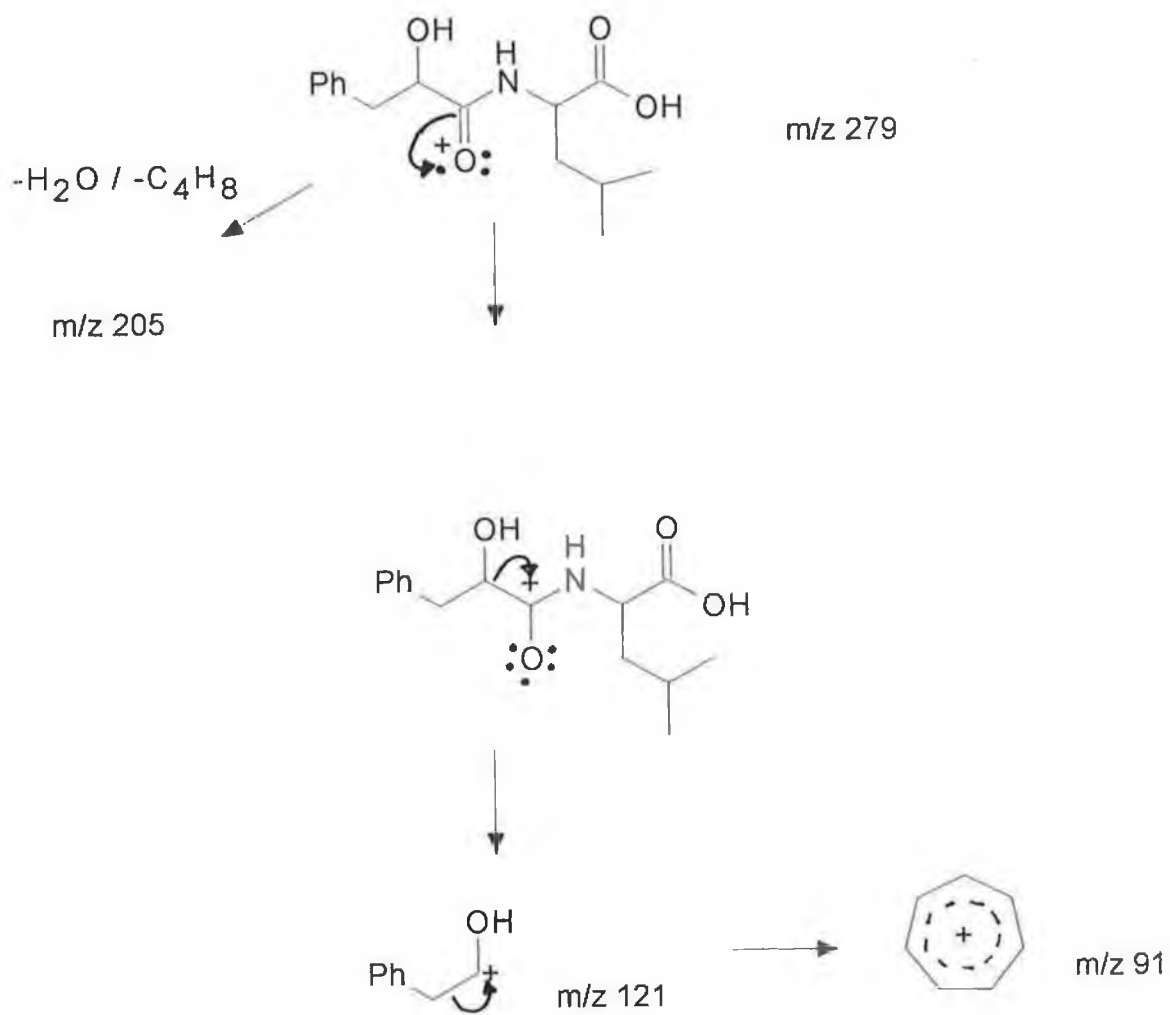

Fig 4.10 (Continued from previous page).

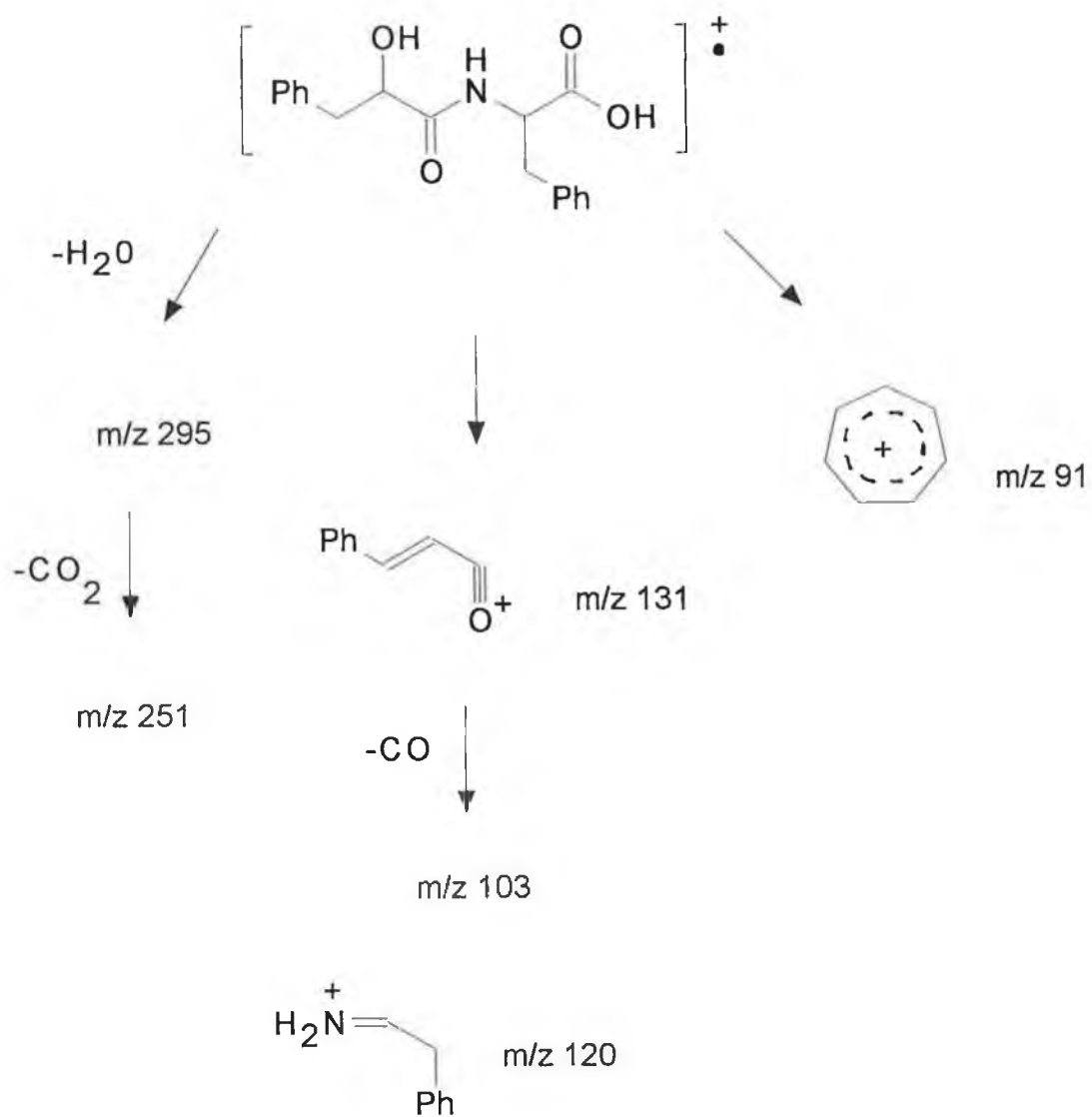
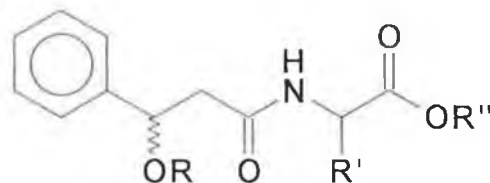

Fig. 4.11 EI fragmentation of *N*-2-hydroxy-3-phenylpropionyl-L-phenylalanine (21d).

4.3 N-3-Hydroxy-3-phenylpropionyl derivatives



25a R=COCH₃, R'=H, R''=CH₃

25b R=COCH₃, R'=(S)-CH₃, R''=CH₃

25c R=COCH₃, R'=(S)-CH₂Ph, R''=CH₃

26a R=H, R'=H, R''=H

26b R=H, R''=(S)-CH₂Ph, R''=H

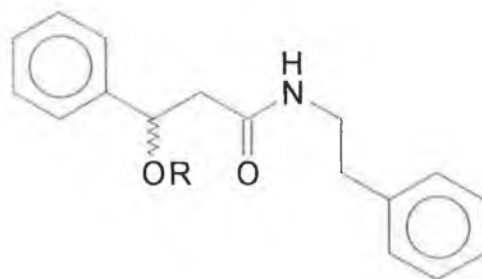

25d R=COCH₃

26c R=H

It was decided to prepare the *N*-3-hydroxy-3-phenylpropionyl derivatives (**26a-c**) in order to observe the effect of placing a methylene spacer between the carbonyl and hydroxy groups of the *N*-2-hydroxy-2-phenylacetyl derivatives. In these derivatives the hydroxy group is β to the amide carbonyl unlike the previously described inhibitors in which the hydroxy group is α to the carbonyl. This type of derivative may yield more information about the binding of the inhibitors to the active site. Another interesting

feature of these derivatives is that intramolecular hydrogen bonding between the hydroxy and carbonyl groups may occur (fig. 4.12). This type of interaction reduces intermolecular interactions and may allow this type of inhibitor improved transport across cell membranes.

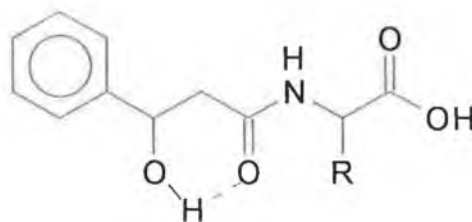

**Fig. 4.12 Possible intramolecular hydrogen bonding in
N-3-hydroxy-3-phenylpropionyl amino acid.**

The starting material 3-hydroxy-3-phenylpropionic acid (**23**) was prepared by a *Reformatsky* reaction by treating benzaldehyde with zinc and ethyl bromoacetate to yield a racemic mixture of ethyl-3-hydroxy-3-phenylpropanoate (**22**).¹²¹ Alkaline hydrolysis of the ester yielded the β -hydroxy acid. The hydroxy group was protected as the acetate by treatment with acetyl chloride to yield the 3-acetoxy-3-phenylpropionic acid (**24**) which was coupled with DCCD to the amino acid methyl ester to yield the *N*-3-acetoxy-3-phenylpropionyl derivatives (**25**). Subsequent base catalyzed hydrolysis yielded the *N*-3-hydroxy-3-phenylpropionyl derivatives (**26**) as diastereomeric mixtures, which were not separated for reasons described previously for the *N*-2-hydroxy-2-phenylacetyl derivatives. We were unable to prepare the *N*-3-acetoxy-3-phenylpropionyl-L-leucine methyl ester and were unable to isolate *N*-3-hydroxy-3-phenylpropionyl-L-alanine after hydrolysis of *N*-3-acetoxy-3-phenylpropionyl-L-alanine methyl ester.

Scheme IV

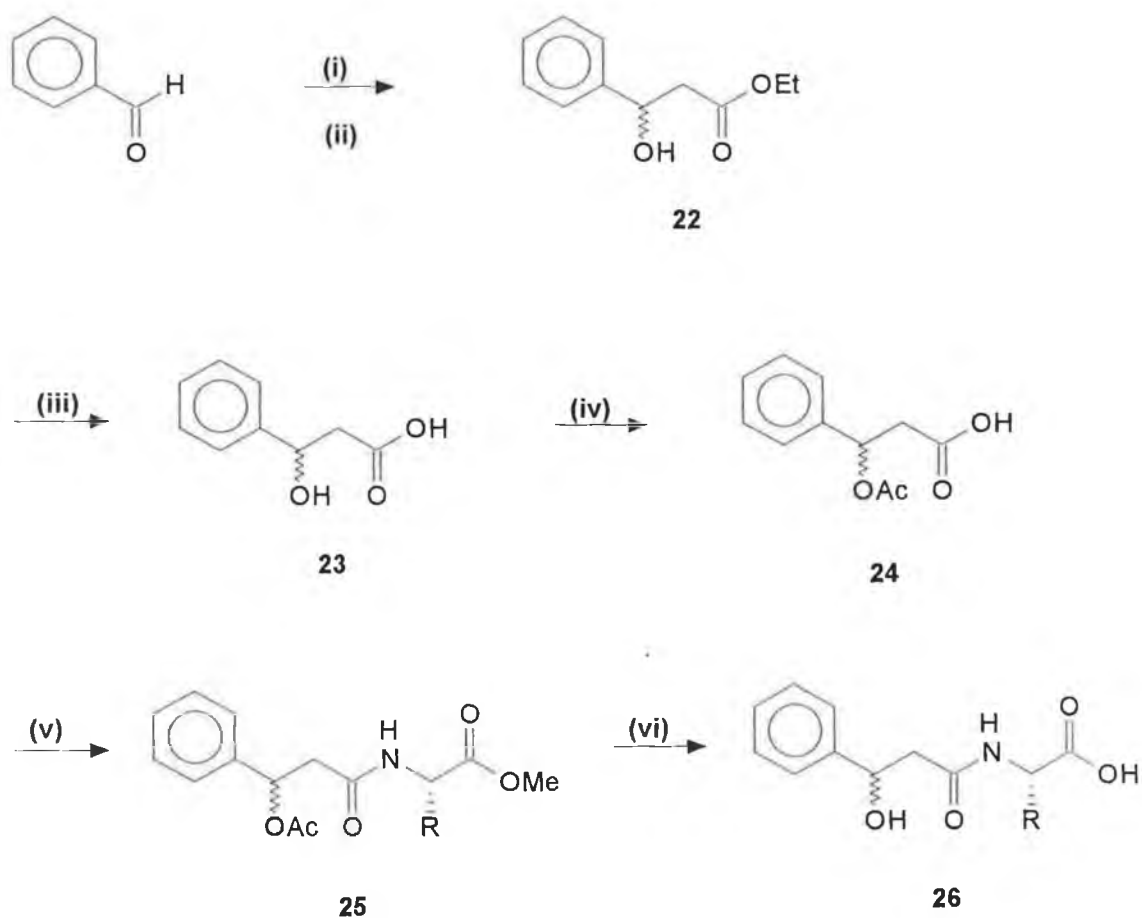

(i) Zn, BrCH₂CO₂Et, Et₂O, Toluene

(ii) H₂SO₄

(iii) 1M NaOH, MeOH

(iv) AcCl

(v) Amino acid methyl ester hydrochloride, DCCD, Et₃N, DCM

(vi) 1M NaOH, MeOH

The i.r. spectra of the 3-acetoxy-3-phenylpropionyl derivatives have a characteristic NH peaks at 3300cm⁻¹ and carbonyl peak at 1740cm⁻¹ due to the ester or acetate carbonyl. A peak observed at 1650cm⁻¹ is due to the amide carbonyl. Aromatic absorptions are also noted. The ¹H-n.m.r. spectra have a complex multiplet stretching from δ 7.25 to δ 7.35 which integrates as ten protons due to the aromatic protons. Two

signals in the region δ 6.0-6.2 which integrate as two protons each and may actually obscure each other are due to the amide protons and the β -protons of the 3-acetoxy-3-phenylpropionyl moiety. The β -protons of the 3-acetoxy-3-phenylpropionyl moiety appear as two doublets. This is due to the fact of being split by two protons which are non-equivalent because they are adjacent to a chiral centre. Singlets at δ 3.7 and δ 2.0 which both integrate as six protons correspond to the methyl ester and acetate protons respectively. Two pairs of doublets at δ 2.65 and δ 2.85 which integrate as two protons each are due to the methylene protons of the 3-acetoxy-3-phenylpropionyl moiety. The ^{13}C -n.m.r spectra have three carbonyl signals at δ 168, δ 170 and δ 172 corresponding to the methyl ester acetate and amide carbonyl carbons. Four signals due to the four non-equivalent aromatic carbons are seen in the region δ 126-140. The signals due to the methylene and β -carbons of the 3-acetoxy-3-phenylpropionyl moiety occur at δ 41 and δ 72 respectively.

The i.r. spectra of the 3-hydroxy-3-phenylpropionyl derivatives exhibit an OH peak at 3300cm^{-1} . Two carbonyl peaks are observed at 1720cm^{-1} and 1650cm^{-1} due to the acid and amide carbonyls respectively. Aromatic absorptions are also noted. The ^1H -n.m.r. spectra of the 3-hydroxy-3-phenylpropionyl derivatives are similar to the spectra of the 3-acetoxy-3-phenylpropionyl derivatives. A signal at δ 8.2 which integrates as two protons is due to the amide protons. A complex multiplet which is observed in the region δ 7.2-7.4 and which integrates as ten protons corresponds to the aromatic protons. A pair of doublets in the range δ 4.9-5.1 which integrate as two protons are due to the β -protons of the 3-hydroxy-3-phenylpropionyl-moiety. A pair of doublets which is observed in the region δ 3.65-3.85 and which integrate as four protons correspond to the methylene protons of the 3-hydroxy-3-phenylpropionyl moiety. The ^{13}C -n.m.r. spectra have two carbonyl signals at δ 171 and 170 which correspond to the carboxylic acid and amide carbonyl carbons. Four signals due to the four non-equivalent aromatic carbons are observed in the region δ 125-145. Signals at δ 70 and δ 45 are due to the methylene and α carbons of the 3-hydroxy-3-phenylpropionyl moiety respectively.

4.4 N-2-Thio-2-phenylacetyl derivatives

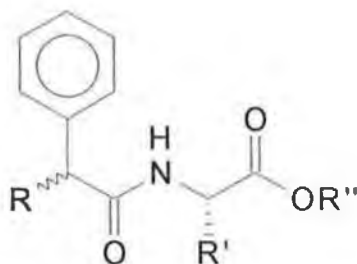

27a $\text{R}=\text{OH}$, $\text{R}'=\text{CH}_2\text{CH}(\text{CH}_3)_2$, $\text{R}''=\text{CH}_3$

27b $\text{R}=\text{OH}$, $\text{R}'=\text{CH}_2\text{Ph}$, $\text{R}''=\text{CH}_3$

28a $\text{R}=\text{OSO}_2\text{CH}_3$, $\text{R}'=\text{CH}_2\text{CH}(\text{CH}_3)_2$, $\text{R}''=\text{CH}_3$

28b $\text{R}=\text{OSO}_2\text{CH}_3$, $\text{R}'=\text{CH}_2\text{Ph}$, $\text{R}''=\text{CH}_3$

29a $\text{R}=\text{SCOCH}_3$, $\text{R}'=\text{CH}_2\text{CH}(\text{CH}_3)_2$, $\text{R}''=\text{CH}_3$

29b $\text{R}=\text{SCOCH}_3$, $\text{R}'=\text{CH}_2\text{Ph}$, $\text{R}''=\text{CH}_3$

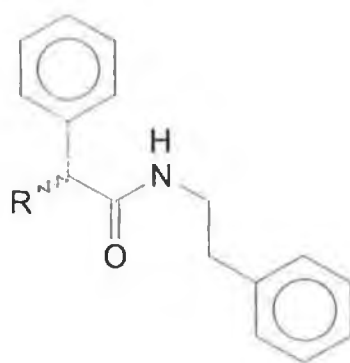

28c $\text{R}=\text{OSO}_2\text{CH}_3$

29c $\text{R}=\text{SCOCH}_3$

30 $\text{R}=\text{SH}$

The *N*-2-thio-2-phenylacetyl derivatives were prepared in order to observe the effect of replacing the hydroxy group of the *N*-2-hydroxy-2-phenylacetyl derivatives with a thiol functionality. It is known that sulphur has a high affinity for metals found at the active site of metalloproteases and it was hoped that a strong hydrogen bonding interaction between the sulphhydryl group and active site metal (fig. 4.13) would make these derivatives potent inhibitors. Many of the most potent aminopeptidase inhibitors contain a thiol group.

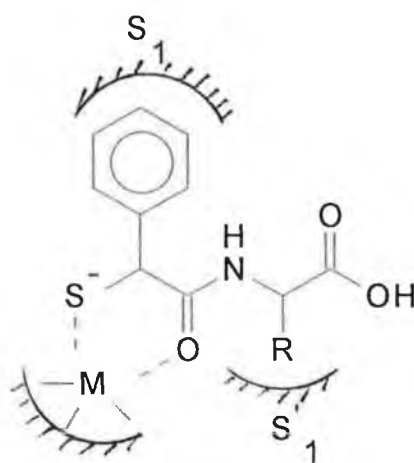
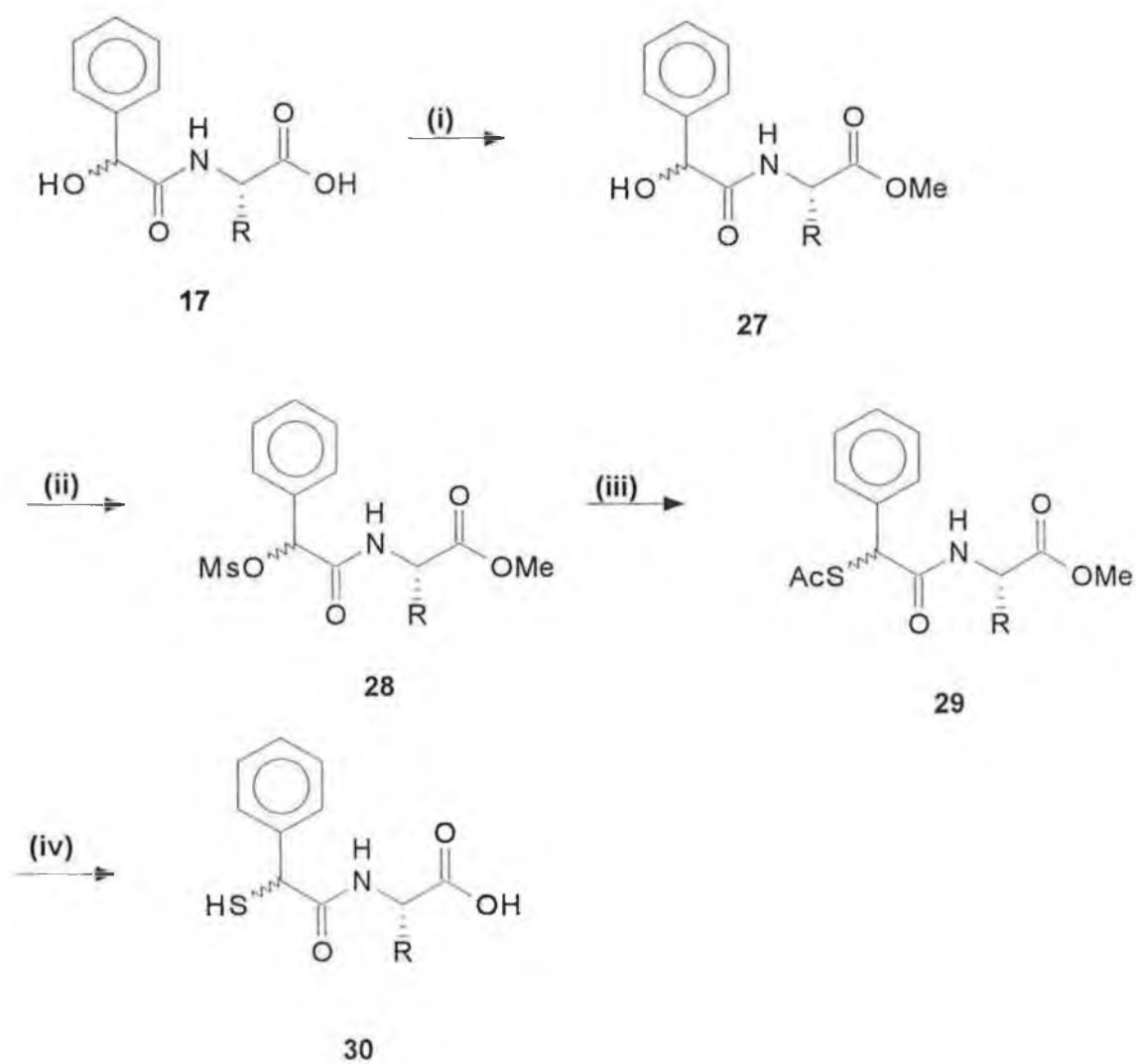

Fig. 4.13 Proposed binding of *N*-2-thio-2-phenylacetyl-amino acid to the active site metal.

The *N*-2-thio-2-phenylacetyl derivatives (**30**) were prepared from the corresponding *N*-2-hydroxy-2-phenylacetyl derivatives (**17**). It was chosen to prepare only the derivatives of L-leucine, L-phenylalanine and phenethylamine since these were the derivatives for which we had the starting material in greatest abundance. The carboxylic acid was first protected as the methyl ester by treatment with thionyl chloride and methanol. Treatment of the resulting protected *N*-2-hydroxy-2-phenylacetyl derivative (**27**) with methanesulphonyl chloride¹¹⁹ yielded the corresponding mesylates (**28**). Displacement of the mesylate with potassium thioacetate yielded the *N*-acethio-2-phenylacetyl (**29**) derivatives as a mixture of diastereomers. We were unable to isolate the thiol derivatives of L-leucine and L-phenylalanine, perhaps due to the high reactivity of the thiol, or hydrolysis conditions which were too severe. However we did prepare

the thiol derivative of phenethylamine (**30**). The acethio derivatives may be active *in vivo*, as enzymatic degradation of the thioester and acetate may furnish the active thiol metabolite, and so these compounds were also tested. They may also be better able to cross the cell membrane.

Scheme V



(i) SOCl_2 , MeOH

(ii) MsCl, Et_3N , DCM

(iii) Potassium thioacetate, DMF

(iv) 1M NaOH, MeOH

The i.r. spectra of the mesylates (**28a-c**) exhibit an NH stretching frequency peak at 3400cm^{-1} . Peaks observed at 1730 and 1660cm^{-1} are due to the ester and amide carbonyls respectively. Aromatic absorptions are also noted. The ^1H -n.m.r. spectra of the mesylates (**28a-c**) are similar to the spectra of *N*-2-acetoxy-2-phenylacetyl derivatives (**16**). The signal due to methanesulphonyl substituent protons is observed at δ 2.85 and δ 2.95 as two diastereomeric singlets which together integrate as six protons. The singlet at δ 5.9 which integrates as two protons corresponds to the α -protons of the *O*-methanesulphonyl-2-hydroxy-2-phenylacetyl moiety. A signal observed at δ 39 in the ^{13}C -n.m.r. spectra is due to the methanesulphonyl methyl carbon. The signal due to the α -carbon of the *O*-methanesulphonyl-2-hydroxy-2-phenylacetyl moiety occurs at δ 81. The ester and amide carbonyl carbons give signals at δ 173 and δ 167 respectively.

The i.r. spectra of the thioacetates (**29a-c**) exhibit an NH peak at 3309cm^{-1} . The peaks observed at 1740cm^{-1} and 1650cm^{-1} are due to the ester and amide carbonyls respectively. Aromatic absorptions are observed. The ^1H -n.m.r. spectra of the thioacetates (**29a-c**) are also similar to the *N*-2-acetoxy-2-phenylacetyl derivatives (**17**). The signal due to the thioacetate group protons are observed at in the range δ 2.33-2.35 as two diastereomeric singlets which together integrate as six protons. The two diastereomeric singlets in the region δ 5.18-5.20 which together integrate as two protons correspond to the α -proton of the 2-acethio-2-phenylacetyl moiety. A signal observed at δ 30 in the ^{13}C -n.m.r. is due to the thioacetate methyl carbon. The α -carbon of the 2-acethio-2-phenylacetyl moiety occurs at δ 52. A signal corresponding to the thioacetate carbonyl carbon is observed at δ 195.

The i.r. spectrum of *N*-2-thio-2-phenylacetyl-phenethylamide (**30**) exhibits an NH peak at 3293cm^{-1} . The peak observed at 1652cm^{-1} is due to the amide carbonyl. Aromatic absorptions are also observed. The ^1H -n.m.r. spectrum of *N*-2-thio-2-phenylacetyl-phenethylamide (**30**) is similar to *N*-2-hydroxy-2-phenylacetyl phenethylamide (**17d**). The two diastereomeric singlets observed at δ 4.74 correspond to the α -proton of the 2-thio-2-phenylacetyl moiety. The ^{13}C -n.m.r. has a signal at δ 168 due to the amide carbonyl. The signal due to the α -carbon of the 2-thio-2-phenylacetyl moiety occurs at δ 58.

4.5 Attempted synthesis of α -hydroxy- β -amino acid (AHBA) isosteres

Paradoxically most of the problems associated with peptide-based protease inhibitors as therapeutic agents are due to their very nature as peptides. The peptide bond is capable of forming hydrogen bonding interactions and is thus very hydrophilic. For this reason peptide-based inhibitors interact poorly with lipophilic cell membranes and their transportation across the cell membrane is reduced. In addition rapid enzymatic degradation of the peptide bond results in short lifetimes *in vivo*.

To overcome this problem it was decided to prepare some simple α -hydroxy- β -amino acid isosteres where the amide bond was replaced with a *trans* -C=C- bond. These compounds would mimic the AHBA moiety found in bestatin and amastatin (fig.4.14) and may be able to chelate the active-site metal via the amino and hydroxyl functionalities (fig. 4.15) in a similar manner to that described by Nishizawa *et al* for bestatin.¹¹⁶ They would not however have the problems associated with their peptidyl counterparts. Examples of such compounds occur in nature. Merucathin (fig. 4.16) is a β -amino-allylic alcohol found in the CNS-active khatamines of *Catha edulis*.¹⁵⁴ It has been synthesized by treating *N*-protected alanine with stryllithium followed by deprotection,¹⁵⁵ or *via* a *Schenk* reaction from the corresponding acylated allylic amine.¹⁵⁶

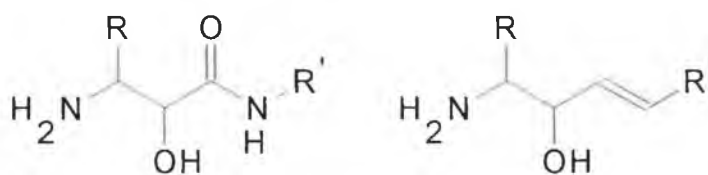

(a) $\text{R}=\text{CH}_2\text{CH}(\text{CH}_3)_2$ (Amastatin-type)

(b) $\text{R}=\text{CH}_2\text{Ph}$ (Bestatin-type)

Fig. 4.14 Comparison of AHBA and AHBA isosteres.

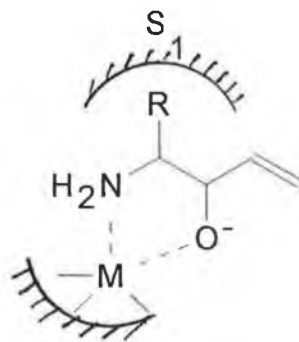

Fig. 4.15 Possible mode of binding of AHBA isostere to active site metal.

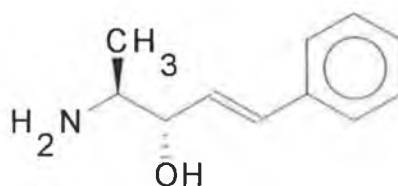

Fig. 4.16 Merucathin.

The *trans* -C=C- bond has similar spatial requirements to the amide bond and there is a surprisingly similar geometrical disposition of substituents attached to either of these functional groups (fig. 4.16).¹⁵⁷ X-ray crystallographic data show that amide bonds in peptides usually adopt a planar configuration with groups attached to the central bond in a *trans*-orientation. Upon comparing both structures it is observed that the distance a-b is 3.8 Å. The difference in direction of bond approach is only 5° but in flexible molecules such as peptides this becomes almost irrelevant to the overall geometry. Thus assuming the amide bond in bestatin was of secondary importance to the amino and hydroxyl groups in terms of tight binding to the active site of the aminopeptidase it should be possible to prepare simple AHBA analogues with improved abilities to traverse cell membranes and a longer lifetime *in vivo*.

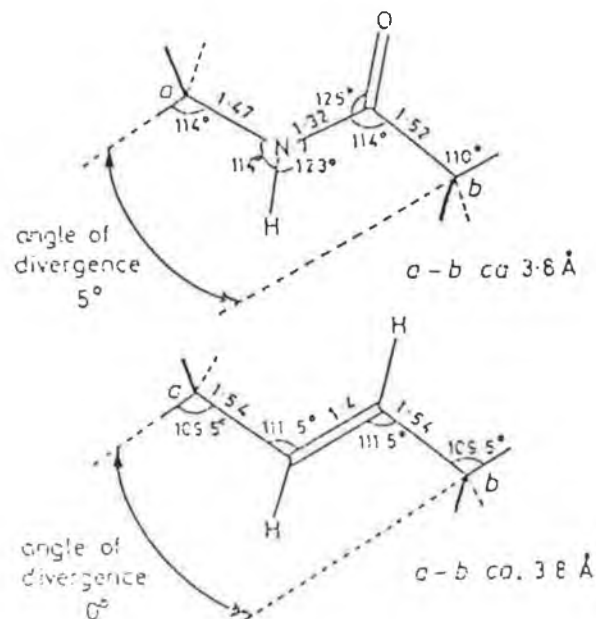
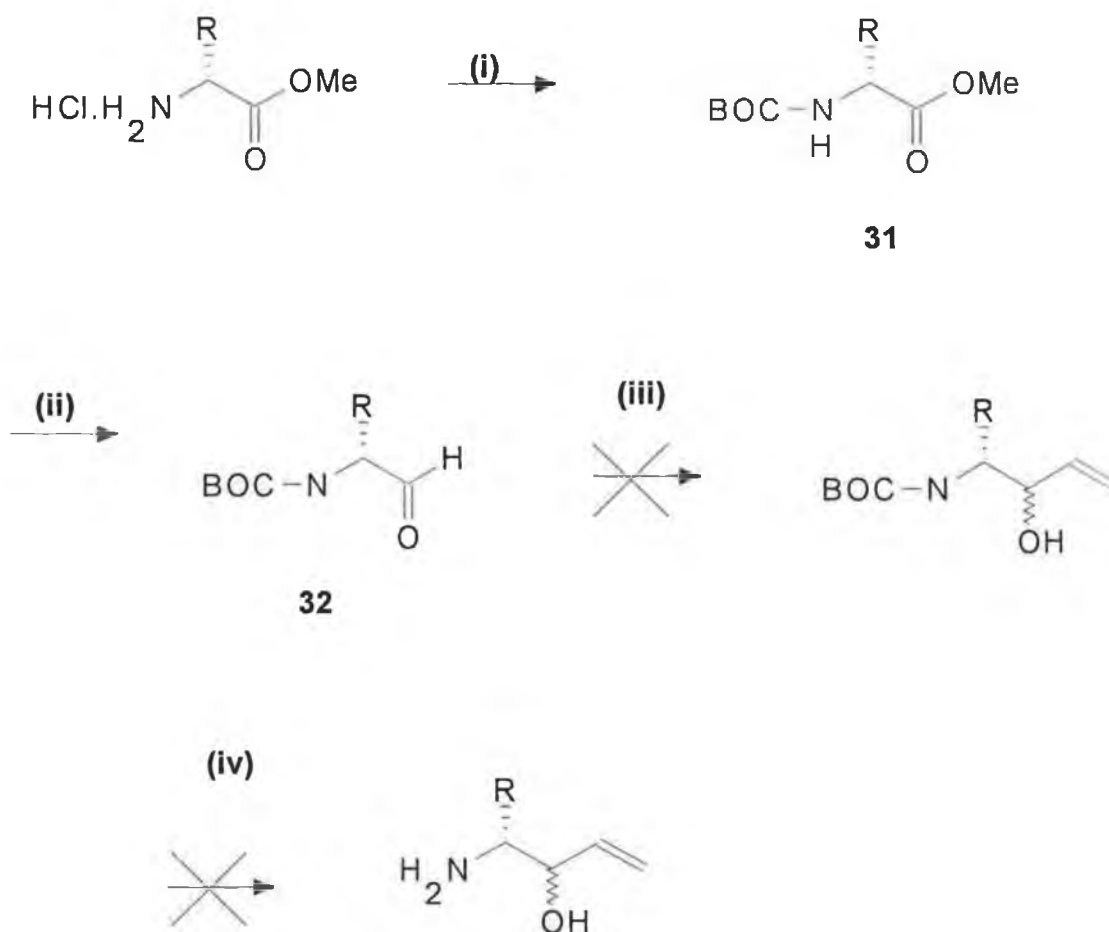

Fig. 4.17 Spatial arrangement of amide and *trans* -C=C- bonds.¹⁵⁷

The starting material for these compounds was the corresponding D-amino acid. This would give the correct 3(*R*) stereochemistry at the carbon attached to the amino group. It was decided to prepare the derivatives of D-phenylalanine and D-leucine to yield the bestatin-type and amastatin-type AHBA isosteres respectively. The carboxylic acid was converted to the methyl ester by treatment with thionyl chloride in methanol. The amino group was then protected as the *tert*-butyl carbamate using di-*tert*-butyl-dicarbonate. Reduction of the BOC amino acid methyl esters (**31a,b**) with diisobutylaluminium hydride yielded the corresponding BOC amino aldehydes (**32a,b**). It was then attempted to react the aldehyde with vinyl magnesium bromide to yield the BOC amino allylic alcohol as a mixture of diastereomers.¹⁵⁸ Removal of the BOC protecting group with trifluoroacetic acid^{123,124} would then yield the desired product. However we were unable to isolate the BOC amino allylic alcohols from the reaction mixture.

Scheme VI



(i) Di-*tert*-butyl-dicarbonate, Et_3N , DCM

(ii) DIBAL, Toluene

(iii) Vinyl magnesium bromide, THF

(iv) TFA

The i.r. spectra of the BOC amino acid esters (**31a,b**) have an NH stretching frequency peak at 3400cm^{-1} . An ester carbonyl peak is observed at 1750cm^{-1} . A singlet observed at δ 1.4 in the ^1H -n.m.r. spectra which integrates as nine protons is due to the *tert*-butyl protons. The *tert*-butyl methyl carbons give a signal at δ 28 in the ^{13}C -n.m.r.

The i.r. spectra of the BOC amino aldehydes exhibits a signal at 3400cm^{-1} due to the NH stretching frequency. The aldehydic carbonyl gives a singlet at 1690cm^{-1} . A signal observed at δ 1.44 in the ^1H -n.m.r. spectra is due to the *tert*-butyl protons. The aldehydic proton is observed at δ 9.6. The ^{13}C -n.m.r. spectra of the BOC-amino aldehydes again shows a characteristic signal at δ 28 corresponding to the *tert*-butyl methyl carbons. The signal due to the aldehydic carbonyl carbon occurs at δ 200.

4.6 Experimental

N-((*R/S*)-2-Acetoxy-2-phenylacetyl) glycine methyl ester (16a)

O-Acetylmandelic chloride (2.25ml, 0.01mol) in dichloromethane (50ml) was added dropwise to a solution of glycine methyl ester hydrochloride (1.26g, 0.01mol) and triethylamine (2.1ml, 0.015mol) in dichloromethane (50ml) at 0°C. After 30min the reaction temperature was increased to room temperature and the reaction allowed to proceed for 4hr. The solution was washed with 10% sodium hydrogen carbonate, 5% hydrochloric acid, water and dried. The solvent was removed *in vacuo*. Recrystallization from ethyl acetate/petroleum ether furnished the title compound as an off-white solid (2.18g, 82%). m.p. 124-126°C (uncorrected).

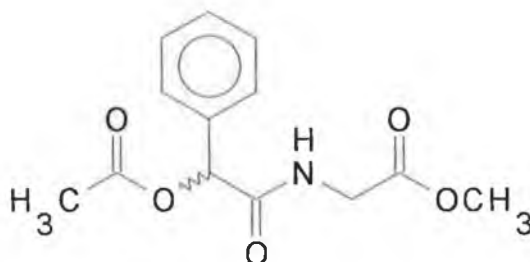

Spectroscopic analysis

i.r. ν_{\max} (KBr): 3312 (NH), 1747 (ester/acetate C=O), 1670 (amide C=O), 1538, 1455, 1436, 1374, 1226, 1155, 1046 cm^{-1} .

$^1\text{H-n.m.r.}$ (400MHz) δ (CDCl_3): 2.19 (6H, s, $\text{PhCH}(\text{OCOCH}_3)\text{CO-}$), 3.76 (6H, s, $-\text{NHCH}_2\text{CO}_2\text{CH}_3$), 4.07 (4H, m, $-\text{NHCH}_2\text{CO}_2\text{CH}_3$), 6.13 (2H, s, $\text{PhCH}(\text{COOCH}_3)\text{CO-}$), 6.79 (2H, s, $-\text{NH}$), 6.79-7.80 (10H, m, ArH).

$^{13}\text{C-n.m.r.}$ (100MHz) δ (CDCl_3): 172.69 ($-\text{NHCH}_2\text{CO}_2\text{CH}_3$), 169.98, 169.11, ($\text{PhCH}(\text{OCOCH}_3)\text{CO-}$ and $\text{PhCH}(\text{OCOCH}_3)\text{CO-}$), 135.18, 129.06, 128.73, 127.49 (aromatic carbons), 75.27 ($\text{PhCH}(\text{OCOCH}_3)\text{CO-}$), 52.44, ($-\text{NHCH}_2\text{CO}_2\text{CH}_3$), 40.95 ($-\text{NHCH}_2\text{CO}_2\text{CH}_3$), 20.93 ($\text{PhCH}(\text{OCOCH}_3)\text{CO-}$).

N-((*R/S*)-2-Hydroxy-2-phenylacetyl) glycine (17a)

1M NaOH (25ml) was added to a solution of *N*-((*R/S*)-2-acetoxy-2-phenylacetyl) glycine methyl ester (3.2g, 0.01mol) in methanol (20ml) and allowed to stir at room temperature for 1hr. The solution was then cooled to 0°C and acidified with 10% hydrochloric acid. The solvent was allowed to evaporate over a period of time. The resulting solid was extracted into acetone, filtered and the solvent removed *in vacuo*. Recrystallization from acetone/*n*-hexane yielded the title compound as a white crystalline solid (1.95g, 93%).

m.p. 122-124°C (uncorrected).

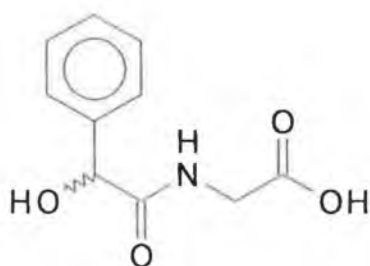

Spectroscopic analysis

i.r. ν_{\max} (KBr): 3237 (OH), 3053, 1724 (carboxylic acid C=O), 1647 (amide C=O), 1536, 1451, 1413, 1271, 1240, 1062 cm^{-1} .

^1H -n.m.r.(400MHz) δ (DMSO): 3.78 (4H, d, $J=4\text{Hz}$, $-\text{NHCH}_2\text{CO}_2\text{H}$), 4.96 (2H, s, $\text{PhCH}(\text{OH})\text{CO}-$), 7.24-7.44 (10H, m, ArH), 8.25 (2H, d, $J=4\text{Hz}$, $-\text{NH}$).

^{13}C -n.m.r.(100MHz) δ (DMSO): 172.60, 171.29 ($-\text{NHCH}_2\text{CO}_2\text{H}$ and $\text{PhCH}(\text{OH})\text{CO}-$), 141.29, 128.06, 127.57, 126.99 (aromatic carbons), 73.45 ($\text{PhCH}(\text{OH})\text{CO}-$), 40.56 ($-\text{NHCH}_2\text{CO}_2\text{H}$).

Mass spectrum m/z (%): 209 (1.5), 191 (0.7) $[M-H_2O]^+$, 107 (100), 77 (24), 30 (15) (immonium ion of Gly).

Calc. for $C_{10}H_{11}NO_4$ M^+ m/z : 209

N-((R/S)-2-Acetoxy-2-phenylacetyl)-L-alanine methyl ester (16b)

O-Acetylmandelic chloride (2.25ml, 0.01mol) in dichloromethane (50ml) was added dropwise to a solution of L-alanine methyl ester hydrochloride (1.4g, 0.01mol) and triethylamine (2.1ml, 0.015mol) in dichloromethane (50ml), at 0°C. After 30min, the reaction temperature was increased to room temperature, and the reaction allowed to proceed for 4hr. The solution was washed with 10% sodium hydrogen carbonate, 5% hydrochloric acid, water, and dried. The solvent was removed *in vacuo*, and purification of the resultant oil by recrystallization from ethyl acetate/petroleum ether furnished the title compound as a yellow solid (2.18g, 78%).

m.p. 54-56°C (uncorrected).

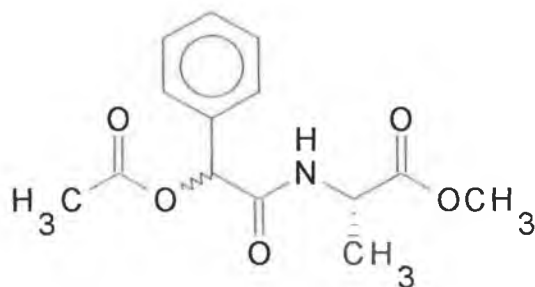

Spectroscopic analysis

i.r. ν_{max} (KBr): 3319 (NH), 1748 (ester/acetate C=O), 1662 (amide C=O), 1537, 1435, 1419, 1371, 1229, 1048 cm^{-1} .

1H -n.m.r.(400MHz) δ ($CDCl_3$): 1.41 (6H, d, $J=7.4Hz$, $-NHCH(\underline{CH_3})CO_2CH_3$), 2.17&2.19 (6H, 2 diastereomeric singlets, $PhCH(OCO\underline{CH_3})CO-$), 3.73 (6H, 2 diastereomeric singlets,

-NHCH(CH₃)CO₂CH₃), 4.55-4.63 (2H, m, -NHCH(CH₃)CO₂CH₃), 6.08&6.11 (2H, 2 diastereomeric singlets, PhCH(OCOCH₃)CO-), 6.91 (2H, m, -NH), 7.33-7.45 (10H, m, ArH).

¹³C-n.m.r.(100MHz)δ(CDCl₃): 172.70 (-NHCH(CH₃)CO₂CH₃), 169.02, 168.93, 167.70, 167.67 (PhCH(OCOCH₃)CO- and PhCH(OCOCH₃)CO-), 135.18, 135.00, 128.63, 128.46, 128.35, 127.33, 127.28, 127.12 (aromatic carbons), 74.94 (PhCH(OCOCH₃)CO-), 52.24, 52.14 (-NHCH(CH₃)CO₂CH₃), 47.63, 47.60 (-NHCH(CH₃)CO₂CH₃), 20.58, 20.54 (PhCH(OCOCH₃)CO-), 17.74, 17.66 (-NHCH(CH₃)CO₂CH₃).

Mass spectrum: [M+H]⁺ found 280.11833 C₁₄H₁₈NO₅ requires 280.0517

Attempted preparation of N-((R/S)-2-hydroxy-2-phenylacetyl)-L-alanine

1M NaOH (25ml) was added to a solution of N-((R/S)-2-acetoxy-2-phenylacetyl)-L-alanine methyl ester (2.8g, 0.01mol) in methanol (20ml) and allowed to stir at room temperature for 1hr. The solution was then cooled to 0°C and acidified with 10% hydrochloric acid. The solvent was allowed to evaporate over a period of time. The resulting yellow oil was extracted into acetone, filtered and the solvent removed *in vacuo*. Purification by flash chromatography [chloroform/methanol(9.5:0.5)] did not yield the desired product and the reaction was not investigated further.

N-((R/S)-2-Acetoxy-2-phenylacetyl)-L-leucine methyl ester (16c)

O-Acetylmandelic chloride (2.25ml, 0.01mol) in dichloromethane (50ml) was added dropwise to a solution of L-leucine methyl ester hydrochloride (1.8g, 0.01mol) and triethylamine (2.1ml, 0.015mol) in dichloromethane (50ml) at 0°C. After 30min the reaction temperature was increased to room temperature and the reaction allowed to proceed for 4hr. The solution was washed with 10% sodium hydrogen carbonate, 5% hydrochloric acid, water and dried. The solvent was removed *in vacuo* and purification of the resultant oil by

recrystallization from ethyl acetate/petroleum ether furnished the title compound as a white crystalline solid (2.31, 72%). m.p. 64-66°C (uncorrected).

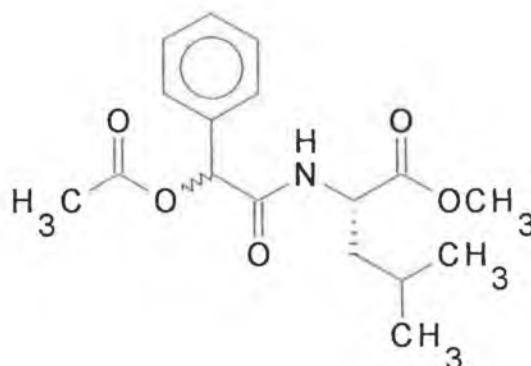

Spectroscopic analysis

i.r. ν_{\max} (KBr): 3329 (NH), 2961, 1753, 1733 (ester/acetate C=O), 1661 (amide C=O), 1539, 1372, 1233, 1155 cm^{-1} .

^1H -n.m.r.(400MHz) δ (CDCl_3): 0.87-0.90 (12H, dd, $J_A=9.36\text{Hz}$, $J_B=6.4\text{Hz}$, -NHCH($\text{CH}_2\text{CH}(\text{CH}_3)_2$) CO_2CH_3), 1.49-1.69 (6H, m, -NHCH($\text{CH}_2\text{CH}(\text{CH}_3)_2$) CO_2CH_3 and -NHCH($\text{CH}_2\text{CH}(\text{CH}_3)_2$) CO_2CH_3), 2.17&2.19 (6H, 2 diastereomeric singlets, PhCH(OCOCH $_3$)CO-), 3.70&3.71 (6H, 2 diastereomeric singlets, -NHCH($\text{CH}_2\text{CH}(\text{CH}_3)_2$) CO_2CH_3), 4.60-4.66 (2H, m -NHCH($\text{CH}_2\text{CH}(\text{CH}_3)_2$) CO_2CH_3), 6.06&6.09 (2H, 2 diastereomeric singlets, PhCH(OCOCH $_3$)CO-), 6.54 (2H, m, -NH), 7.30-7.50 (10H, m, ArH).

^{13}C -n.m.r.(100MHz) δ (CDCl_3): 173.03 (-NHCH($\text{CH}_2\text{CH}(\text{CH}_3)_2$) CO_2CH_3), 169.09, 168.02, 167.98 (PhCH(OCOCH $_3$)CO- and PhCH(OCOCH $_3$)CO-), 135.30, 135.24, 129.02, 128.97, 128.70, 127.60, 127.27 (aromatic carbons), 75.38, 75.33 (PhCH(OCOCH $_3$)CO-), 50.52, 50.49 (-NHCH($\text{CH}_2\text{CH}(\text{CH}_3)_2$) CO_2CH_3), 41.60, 41.48 (-NHCH($\text{CH}_2\text{CH}(\text{CH}_3)_2$) CO_2CH_3), 24.80, 24.76 (-NHCH($\text{CH}_2\text{CH}(\text{CH}_3)_2$) CO_2CH_3), 22.70, 22.65 (-NHCH($\text{CH}_2\text{CH}(\text{CH}_3)_2$) CO_2CH_3), 21.93, 21.82 (PhCH(OCOCH $_3$)CO-), 20.93 (-NHCH($\text{CH}_2\text{CH}(\text{CH}_3)_2$) CO_2CH_3).

N-((*R/S*)-2-Hydroxy-2-phenylacetyl)-*L*-leucine (17b)

1M NaOH (25ml) was added to a solution of *N*-((*R/S*)-2-acetoxy-2-phenylacetyl)-*L*-leucine methyl ester (3.2g, 0.01mol) in methanol (20ml) and allowed to stir at room temperature for 1hr. The solution was then cooled to 0°C and acidified with 10% hydrochloric acid. The methanol was removed *in vacuo* and the solution allowed to cool. The resultant white precipitate was filtered and recrystallized from acetone/*n*-hexane to yield the title compound as a white rhombs (2.3g, 87%).

m.p. 116-118°C (uncorrected).

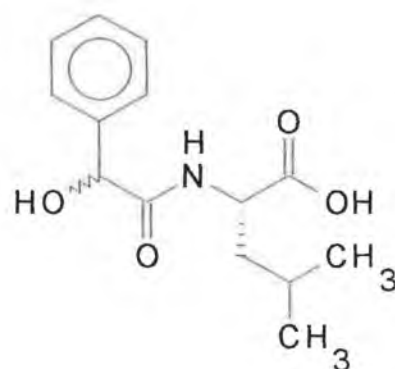

Spectroscopic analysis

i.r. ν_{\max} (KBr): 3459 (OH), 3389 (NH), 3296, 1725 (carboxylic acid C=O), 1639 (amide C=O), 1556, 1267, 1160 cm^{-1} .

$^1\text{H-n.m.r.}$ (400MHz) δ (DMSO): 0.75-0.85 (12H, m, $-\text{NHCH}(\text{CH}_2\text{CH}(\text{CH}_3)_2)\text{CO}_2\text{H}$), 1.46-1.66 (6H, m, $-\text{NHCH}(\text{CH}_2\text{CH}(\text{CH}_3)_2)\text{CO}_2\text{H}$ and $-\text{NHCH}(\text{CH}_2\text{CH}(\text{CH}_3)_2)\text{CO}_2\text{H}$), 4.22-4.28 (2H, m, $-\text{NHCH}(\text{CH}_2\text{CH}(\text{CH}_3)_2)\text{CO}_2\text{H}$), 4.93 (2H, s, $\text{PhCH}(\text{OH})\text{CO}-$), 6.25 (2H, s, $\text{PhCH}(\text{OH})\text{CO}-$), 7.22-7.40 (10H, m, ArH), 7.98-8.00 (2H, d, $J=8.88\text{Hz}$, $-\text{NH}$).

$^{13}\text{C-n.m.r.}$ (100MHz) δ (DMSO): 173.79, 171.94 ($-\text{NHCH}(\text{CH}_2\text{CH}(\text{CH}_3)_2)\text{CO}_2\text{H}$ and $\text{PhCH}(\text{OH})\text{CO}-$), 141.25, 127.89, 127.38, 126.62 (aromatic carbons), 73.28 ($\text{PhCH}(\text{OH})\text{CO}-$), 49.75 ($-\text{NHCH}(\text{CH}_2\text{CH}(\text{CH}_3)_2)\text{CO}_2\text{H}$), 24.32

(-NHCH(CH₂CH(CH₃)₂)CO₂H), 22.83, 21.36 (-NHCH(CH₂CH(CH₃)₂)CO₂H).

Note: The signals at 173.79 and 171.94 may be interchangeable.

Mass spectrum [M-H₂O]⁺⁺ found: 247.1322, C₁₄H₁₇NO₃ requires 247.1207

m/z (%): 247 (0.5) [M-H₂O]⁺⁺, 107 (100), 86 (22) (immonium ion of Leu), 77 (19).

N-((R/S)-2-Acetoxy-2-phenylacetyl)-L-phenylalanine methyl ester (16d)

O-Acetylmandelic chloride (2.25ml, 0.01mol) in dichloromethane (50ml) was added dropwise to a solution of L-phenylalanine methyl ester hydrochloride (2.16g, 0.01mol) and triethylamine (2.1ml, 0.015mol) in dichloromethane (50ml) at 0°C. After 30min the reaction temperature was increased to room temperature and the reaction allowed to proceed for 4hr. The solution was washed with 10% sodium hydrogen carbonate, 5% hydrochloric acid, water and dried. The solvent was removed *in vacuo* and purification of the resultant oil by recrystallization from ethyl acetate/petroleum ether furnished the title compound as a white crystalline solid (2.99g, 84%).

m.p. 88-90°C (uncorrected).

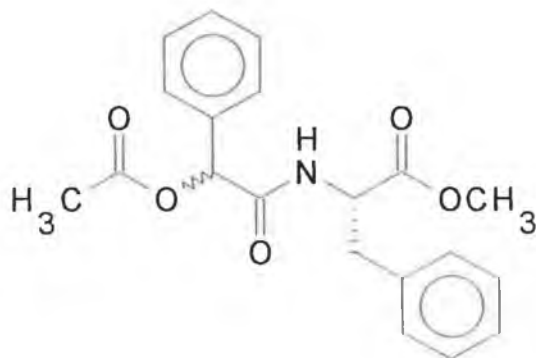

Spectroscopic analysis

i.r. ν_{\max} (KBr): 3367 (NH), 1740 (ester/acetate C=O), 1674 (amide C=O), 1533, 1371, 1220, 1186, 1179, 1123 cm^{-1} .

^1H -n.m.r.(400MHz) δ (CDCl_3): 2.15&2.16 (6H, 2 diastereomeric singlets, $\text{PhCH}(\text{OCOCH}_3)\text{CO-}$), 3.06-3.19 (4H, m, $-\text{NHCH}(\text{CH}_2\text{Ph})\text{CO}_2\text{CH}_3$), 3.74 (6H, s, $-\text{NHCH}(\text{CH}_2\text{Ph})\text{CO}_2\text{CH}_3$), 4.84-4.89 (2H, m, $-\text{NHCH}(\text{CH}_2\text{Ph})\text{CO}_2\text{CH}_3$), 6.04 (2H, s, $\text{PhCH}(\text{OCOCH}_3)\text{CO-}$), 6.65 (2H, d, $J=7.4\text{Hz}$, $-\text{NH}$), 6.96-7.36 (20H, m, ArH).

^{13}C -n.m.r.(100MHz) δ (CDCl_3): 171.56 ($-\text{NHCH}(\text{CH}_2\text{Ph})\text{CO}_2\text{CH}_3$), 169.01, 167.84 ($\text{PhCH}(\text{OCOCH}_3)\text{CO-}$ and $\text{PhCH}(\text{OCOCH}_3)\text{CO-}$), 135.36, 135.07, 129.32, 128.91, 128.67, 128.50, 127.10 (aromatic carbons), 75.39 ($\text{PhCH}(\text{OCOCH}_3)\text{CO-}$), 52.81, 52.43 ($-\text{NHCH}(\text{CH}_2\text{Ph})\text{CO}_2\text{CH}_3$), 37.51 ($-\text{NHCH}(\text{CH}_2\text{Ph})\text{CO}_2\text{CH}_3$), 20.86 ($\text{PhCH}(\text{OCOCH}_3)\text{CO-}$).

N-((*R/S*)-2-Hydroxy-2-phenylacetyl)-*L*-phenylalanine (17c)

1M NaOH (25ml) was added to a solution of *N*-((*R/S*)-2-acetoxy-2-phenylacetyl)-*L*-phenylalanine methyl ester (3.55g, 0.01mol) in methanol (20ml) and allowed to stir at room temperature for 1hr. The solution was then cooled to 0°C and acidified with 10% hydrochloric acid. The methanol was removed *in vacuo*, and the solution allowed to cool. The resultant white precipitate was filtered and recrystallized from acetone/*n*-hexane to yield the title compound as a white rhombs (2.8g, 94 %).

m.p. 174-176°C (uncorrected).

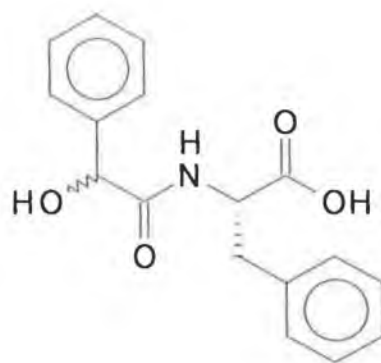

Spectroscopic analysis

i.r. ν_{\max} (KBr): 3357 (OH), 1748, 1722 (carboxylic acid C=O), 1623 (amide C=O), 1526, 1211, 1174, 1062 cm^{-1} .

^1H -n.m.r.(400MHz) δ (DMSO): 2.98-3.09 (4H, m, $-\text{NHCH}(\underline{\text{C}}\text{H}_2\text{Ph})\text{CO}_2\text{H}$), 4.47-4.52 (2H, m, $\text{NHCH}(\underline{\text{C}}\text{H}_2\text{Ph})\text{CO}_2\text{H}$), 4.88 (2H, 2 diastereomeric singlets, $\text{PhCH}(\underline{\text{O}}\text{H})\text{CO}-$), 6.32 (2H, 2 diastereomeric singlets, $\text{PhCH}(\underline{\text{O}}\text{H})\text{CO}-$), 7.07-7.26 (20H, m, ArH), 7.92 (2H, d, $J=8.4\text{Hz}$, $-\text{NH}$).

^{13}C -n.m.r.(100MHz) δ (DMSO): 172.69, 171.70 ($-\text{NHCH}(\underline{\text{C}}\text{H}_2\text{Ph})\underline{\text{C}}\text{O}_2\text{H}$ and $\text{PhCH}(\underline{\text{O}}\text{H})\underline{\text{C}}\text{O}-$), 140.97 137.18, 129.27, 128.21, 128.16, 127.87, 127.40, 126.82, 126.47 (aromatic carbons), 73.36 ($\text{PhCH}(\underline{\text{O}}\text{H})\text{CO}-$), 52.54 ($-\text{NHCH}(\underline{\text{C}}\text{H}_2\text{Ph})\text{CO}_2\text{H}$), 36.35 ($-\text{NHCH}(\underline{\text{C}}\text{H}_2\text{Ph})\text{CO}_2\text{H}$).

Mass spectrum: M^+ found: 299.115758 $\text{C}_{17}\text{H}_{17}\text{NO}_4$ requires 299.11561

m/z (%): 299 (1.6), 281 (5) $[\text{M}-\text{H}_2\text{O}]^+$, 192 (12), 120 (15) (immonium ion of Phe) 107 (100), 91 (76).

N-((R/S)-2-Acetoxy-2-phenylacetyl) phenethylamide (16e)

O-Acetylmandelic chloride (2.25ml, 0.01mol) in dichloromethane (50ml) was added dropwise to a solution of phenethylamine (1.26ml, 0.01mol) and triethylamine (2.1ml, 0.015mol) in dichloromethane (50ml) at 0°C. After 30min the reaction temperature was increased to room temperature and the reaction allowed to proceed for 4hr. The solution was washed with 10% sodium hydrogen carbonate, 5% hydrochloric acid, water and dried. The solvent was removed *in vacuo* and purification of the resultant oil by recrystallization from ethyl acetate/petroleum ether furnished the title compound as an off-white crystalline solid (2.6g, 87%).

m.p. 78-80°C (uncorrected).

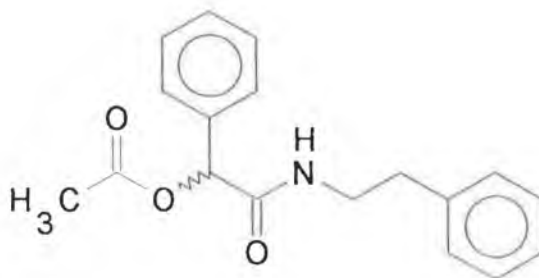

Spectroscopic analysis

i.r. ν_{\max} (KBr): 3334 (NH), 1736 (acetate C=O), 1652 (amide C=O), 1541, 1454, 1371, 1245, 1041 cm^{-1} .

$^1\text{H-n.m.r.}$ (400MHz) δ (CDCl_3): 2.08 (6H, s, $\text{PhCH}(\text{OCOCH}_3)\text{CO-}$), 2.73-2.84 (4H, m, $-\text{NHCH}_2\text{CH}_2\text{Ph}$), 3.43-3.61 (4H, m, $-\text{NHCH}_2\text{CH}_2\text{Ph}$), 6.02 (2H, s, $\text{PhCH}(\text{OCOCH}_3)\text{CO-}$), 6.21 (2H, t, $J=5.9\text{Hz}$, $-\text{NH}$), 7.09-7.37 (20H, m, ArH).

^{13}C -n.m.r.(100MHz) $\delta(\text{CDCl}_3)$: 169.06, 168.16, ($\text{PhCH}(\text{OCOCH}_3)\text{CO-}$ and $\text{PhCH}(\text{OCOCH}_3)\text{CO-}$), 138.47, 135.40, 128.85, 128.74, 128.64, 128.55, 127.24, 126.49 (aromatic carbons) 75.37 ($\text{PhCH}(\text{OCOCH}_3)\text{CO-}$), 40.33 ($-\text{NHCH}_2\text{CH}_2\text{Ph}$), 35.09 ($-\text{NHCH}_2\text{CH}_2\text{Ph}$), 20.84 ($\text{PhCH}(\text{OCOCH}_3)\text{CO-}$).

N-((*R/S*)-2-Hydroxy-2-phenylacetyl) phenethylamide (17d)

1M NaOH (25ml), was added to a solution of *N*-((*R/S*)-acetoxy-2-phenylacetyl) phenethylamide (2.97g, 0.01mol) in methanol (20ml) and allowed to stir at room temperature for 1hr. The solution was then cooled to 0°C and acidified with 10% hydrochloric acid. The methanol was removed *in vacuo*, and the solution allowed to cool. The resultant white precipitate was filtered and recrystallized from acetone/*n*-hexane to yield the title compound¹⁵⁹ as white rhombs (2.27g, 89%).
m.p. $94\text{-}96^\circ\text{C}$ (uncorrected).

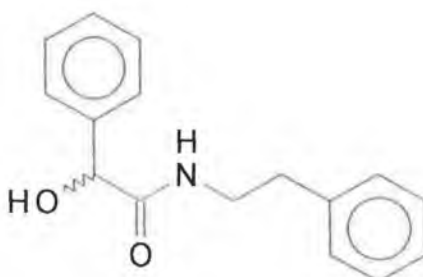

Spectroscopic analysis

i.r. $\nu_{\text{max}}(\text{KBr})$: 3355 (OH), 3164, 1644 (amide C=O), 1551, 1454, 1294, 1194, 1062cm^{-1} .

^1H -n.m.r.(400MHz) $\delta(\text{DMSO})$: 2.71 (4H, t, $J=7.4\text{Hz}$ $-\text{NHCH}_2\text{CH}_2\text{Ph}$), 3.27-3.34 (4H, m, $-\text{NHCH}_2\text{CH}_2\text{Ph}$), 4.88 (2H, d, $J=4.5\text{Hz}$, $\text{PhCH}(\text{OH})\text{CO-}$), 6.13 (2H, d, $J=4.5\text{Hz}$, $\text{PhCH}(\text{OH})\text{CO-}$), 7.14-7.37 (20H, m, ArH), 8.00 (2H, t, $J=5.9\text{Hz}$, $-\text{NH}$).

^{13}C -n.m.r.(100MHz) δ (DMSO): 172.23 (PhCH(OH)CO-), 139.43, 138.40, 128.66, 128.63, 128.52, 128.40, 126.67, 126.43 (aromatic carbons), 73.95 (PhCH(OH)CO-), 40.50 (-NHCH₂CH₂Ph), 35.43 (-NHCH₂CH₂Ph).

N-((S)-2-Acetoxy-3-phenylpropionyl) glycine methyl ester (20a)

Dicyclohexylcarbodiimide (2.1g, 0.01mol) was added to a solution of *O*-acetyl-L- α -phenyllactic acid (2.1g, 0.01mol), glycine methyl ester hydrochloride (1.26g, 0.01mol) and dry pyridine (1.6ml, 0.02mol) in dichloromethane (100ml) at 0°C. After 30min the reaction temperature was raised to room temperature and the reaction allowed to proceed for 6hr. The precipitate of dicyclohexylurea was then removed by filtration. The filtrate was washed with sodium hydrogen carbonate (10%), hydrochloric acid (5%), water and dried. The solvent was removed *in vacuo* and the resultant oil purified by flash chromatography on silica gel [petroleum ether 40-60/ethyl acetate (7:3)] to furnish the title compound as a colourless oil. (2.34g, 84%).

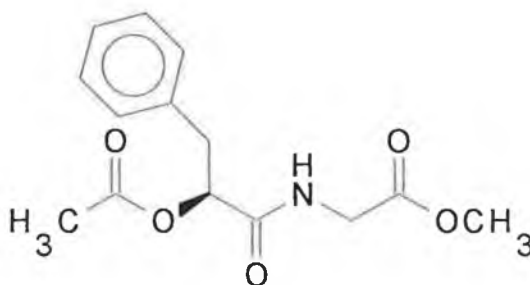

Spectroscopic analysis

i.r. ν_{\max} (CHCl₃): 3324 (NH), 1746 (ester/acetate C=O), 1671 (amide C=O), 1529, 1535, 1498, 1454, 1438, 1409, 1217, 1183, 1081, 1063cm⁻¹.

¹H-n.m.r.(400MHz) δ (CDCl₃): 2.06 (3H, s, PhCH₂CH(OCOCH₃)CO-), 3.11 (1H, dd, J_A=14.28Hz, J_B=7.5Hz, PhCH₂CH(OCOCH₃)CO-), 3.24 (1H, dd, J_A=14.28Hz, J_B=4.4Hz, PhCH₂CH(OCOCH₃)CO-) 3.73 (3H, s, -NHCH₂CO₂CH₃), 4.00 (2H, m, -NHCH₂CO₂CH₃), 5.41 (1H, dd, J_A=7.5Hz, J_B=4.4Hz, PhCH₂CH(OCOCH₃)CO-), 6.66 (1H, t, J=4.6Hz, -NH), 7.17-7.30 (5H, m, ArH).

^{13}C -n.m.r.(100MHz) δ (DMSO): 173.84, 171.22 (-NHCH₂CO₂H and PhCH₂CH(OH)CO-), 138.77, 129.50, 128.00, 126.03 (aromatic carbons), 72.18 (PhCH₂CH(OH)CO-), 40.48 (-NHCH₂CO₂H).

Note: The PhCH₂CH(OH)CO- signal is obscured by the DMSO signal.

Mass spectrum: [M-H₂O]⁺⁺ found: 205.073893 C₁₁H₁₁NO₃ requires 205.07377.

m/z (%): 205 (10) [M-H₂O]⁺⁺, 161 (55), 131 (93), 103 (42), 91 (100), 77 (24).

N-((*S*)-2-Acetoxy-3-phenylpropionyl)-L-alanine methyl ester (20b)

Dicyclohexylcarbodiimide (2.1g, 0.01mol) was added to a solution of *O*-acetyl-L- α -phenyllactic acid (2.1g, 0.01mol), L-alanine methyl ester hydrochloride (1.4g, 0.01mol) and dry pyridine (1.6ml, 0.02mol) in dichloromethane (100ml) at 0°C. After 30min the reaction temperature was increased to room temperature and the reaction allowed to proceed for 6hr. The precipitate of dicyclohexylurea was then removed by filtration. The filtrate was washed with sodium hydrogen carbonate (10%), hydrochloric acid (5%), water and dried. The solvent was removed *in vacuo* and the resultant oil purified by flash chromatography on silica gel [petroleum ether 40-60/ethyl acetate (7:3)] furnishing the title compound as white needles. (2.73g, 93%).

m.p. 78-80°C (uncorrected).

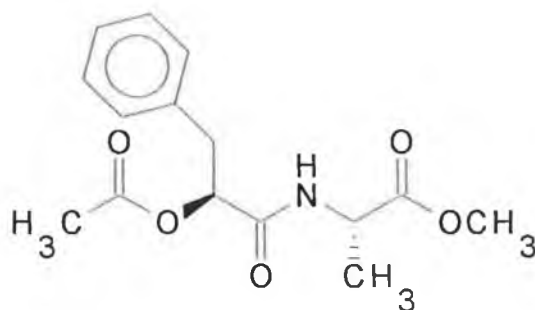

Spectroscopic analysis

i.r. ν_{\max} (KBr): 3297 (NH), 1746 (ester/acetate C=O), 1666 (amide C=O), 1565, 1369, 1271, 1241, 1215, 1196, 1056 cm^{-1} .

^1H -n.m.r.(400MHz) δ (CDCl_3): 1.27 (3H, d, $J=7.36\text{Hz}$, $-\text{NHCH}(\underline{\text{C}}\text{H}_3)\text{CO}_2\text{CH}_3$), 2.12 (3H, s, $\text{PhCH}_2\text{CH}(\text{OCOCH}_3)\text{CO}-$), 3.13-3.23 (2H, m, $\text{PhCH}_2\text{CH}(\text{OCOCH}_3)\text{CO}-$), 3.72 (3H, s, $-\text{NHCH}(\text{CH}_3)\text{CO}_2\text{CH}_3$), 4.51-4.58 (1H, m, $-\text{NHCH}(\text{CH}_3)\text{CO}_2\text{CH}_3$), 5.38-5.41 (1H, m, $\text{PhCH}_2\text{CH}(\text{OCOCH}_3)\text{CO}-$), 6.56 (1H, d, $J=7.36\text{Hz}$, $-\text{NH}$), 7.16-7.30 (5H, m, ArH).

^{13}C -n.m.r.(100MHz) δ (CDCl_3): 172.98 ($-\text{NHCH}(\text{CH}_3)\text{CO}_2\text{CH}_3$), 169.23, 168.27 ($\text{PhCH}_2\text{CH}(\text{OCOCH}_3)\text{CO}-$ and $\text{PhCH}_2\text{CH}(\text{OCOCH}_3)\text{CO}-$), 135.52, 129.56, 128.22, 126.86 (aromatic carbons), 73.88 ($\text{PhCH}_2\text{CH}(\text{OCOCH}_3)\text{CO}-$), 52.46 ($-\text{NHCH}(\text{CH}_3)\text{CO}_2\text{CH}_3$), 47.55 ($-\text{NHCH}(\text{CH}_3)\text{CO}_2\text{CH}_3$), 37.49 ($\text{PhCH}_2\text{CH}(\text{OCOCH}_3)\text{CO}-$), 20.81 ($\text{PhCH}(\text{OCOCH}_3)\text{CO}-$), 18.23 ($-\text{NHCH}(\text{CH}_3)\text{CO}_2\text{CH}_3$).

Note: The signals at 169.23 and 168.27 may be interchangeable.

N-((*S*)-2-Hydroxy-3-phenylpropionyl)-L-alanine (21b)

1M NaOH (25ml) was added to a solution of *N*-((*S*)-2-acetoxy-3-phenylpropionyl)-L-alanine methyl ester (2.93g, 0.01mol) in methanol (20ml) and stirred at room temperature for 1hr. The solution was then cooled to 0°C and acidified with 10% hydrochloric acid. The methanol was removed *in vacuo* and the solution allowed to cool. The resultant white precipitate was filtered and recrystallized from acetone/*n*-hexane to yield the title compound as a white crystalline solid (2.05g, 86 %).

m.p. 102-104°C (uncorrected). Lit. 111°C.¹⁶⁰

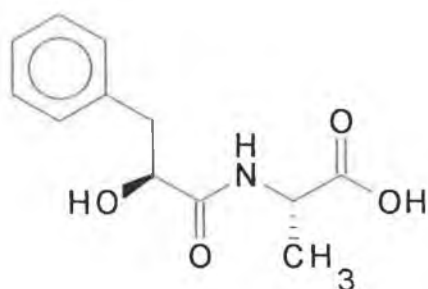

Spectroscopic analysis

i.r. ν_{\max} (KBr): 3383 (OH), 3354 (NH), 1719 (carboxylic acid C=O), 1615 (amide C=O), 1534, 1454, 1212, 1159, 1091 cm^{-1} .

^1H -n.m.r.(400MHz) δ (DMSO): 1.22 (3H, d, $J=7.36\text{Hz}$, $-\text{NHCH}(\text{CH}_3)\text{CO}_2\text{H}$), 2.71 (1H, dd, $J_{\text{A}}=13.28\text{Hz}$, $J_{\text{B}}=8\text{Hz}$, $\text{PhCH}_2\text{CH}(\text{OH})\text{CO}-$), 2.98 (1H, dd, $J_{\text{A}}=13.28\text{Hz}$, $J_{\text{B}}=3.4\text{Hz}$, $\text{PhCH}_2\text{CH}(\text{OH})\text{CO}-$), 4.10 (1H, dd, $J_{\text{A}}=8\text{Hz}$, $J_{\text{B}}=3.4\text{Hz}$, $\text{PhCH}_2\text{CH}(\text{OH})\text{CO}-$), 4.12-4.28 1H, m, $-\text{NHCH}(\text{CH}_3)\text{CO}_2\text{H}$), 5.67, (1H, s, $\text{PhCH}_2\text{CH}(\text{OH})\text{CO}-$), 7.17-7.27 (5H, m, ArH), 7.77 (1H, t, $J=8\text{Hz}$, $-\text{NH}$).

^{13}C -n.m.r.(100MHz) δ (DMSO): 173.97, 172.91 ($-\text{NHCH}(\text{CH}_3)\text{CO}_2\text{H}$ and $\text{PhCH}(\text{OH})\text{CO}-$), 138.43, 129.58, 128.04, 126.17 (aromatic carbons), 71.89 ($\text{PhCH}_2\text{CH}(\text{OH})\text{CO}-$), 47.09 ($-\text{NHCH}(\text{CH}_3)\text{CO}_2\text{H}$), 40.36 ($\text{PhCH}_2\text{CH}(\text{OH})\text{CO}-$), 17.57 ($-\text{NHCH}(\text{CH}_3)\text{CO}_2\text{H}$).

N-((*S*)-2-Acetoxy-3-phenylpropionyl)-*L*-leucine methyl ester (20c)

Dicyclohexylcarbodiimide (2.1g, 0.01mol) was added to a solution of *O*-acetyl-*L*- α -phenyllactic acid (2.1g, 0.01mol), *L*-leucine methyl ester hydrochloride (1.81g, 0.01mol), and dry pyridine (1.6ml, 0.02mol) in dichloromethane (100ml) at 0°C. After 30min the reaction temperature was raised to room temperature and the reaction continued for 6hr. The precipitate of dicyclohexylurea was then removed by filtration. The filtrate was washed with 10% sodium hydrogen carbonate, 5% hydrochloric acid, water and dried. The solvent

was removed *in vacuo* and the resultant oil purified by flash chromatography on silica gel [petroleum ether 40-60/ethyl acetate (7:3)] yielding the title compound as a white needles (2.8g, 85%).

m.p. 64-66°C (uncorrected).

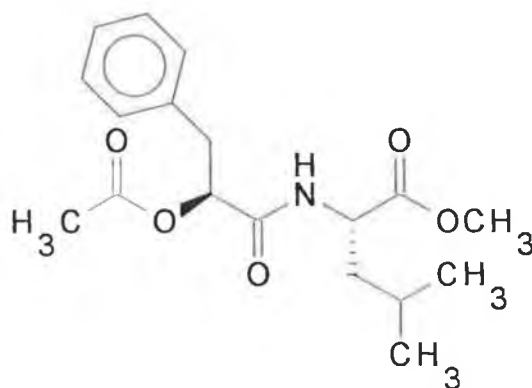

Spectroscopic analysis

i.r. ν_{\max} (KBr): 3267 (NH), 1752 (ester/acetate C=O), 1656 (amide C=O), 1555, 1371, 1239, 1157 cm^{-1} .

^1H -n.m.r.(400MHz) δ (CDCl_3): 0.87 (6H, dd, $J_A=9.36\text{Hz}$, $J_B=6.4\text{Hz}$, -NHCH($\text{CH}_2\text{CH}(\text{CH}_3)_2$)CO $_2$ CH $_3$), 1.32-1.57 (3H, m, -NHCH($\text{CH}_2\text{CH}(\text{CH}_3)_2$)CO $_2$ CH $_3$ and -NHCH($\text{CH}_2\text{CH}(\text{CH}_3)_2$)CO $_2$ CH $_3$), 2.13 (3H, s, PhCH $_2$ CH(OCOCH $_3$ -), 3.13-3.24 (2H, m, PhCH $_2$ CH(OCOCH $_3$ -)CO-), 3.41 (3H, s, -NHCH($\text{CH}_2\text{CH}(\text{CH}_3)_2$)CO $_2$ CH $_3$), 4.56-4.63 (1H, m, -NHCH($\text{CH}_2\text{CH}(\text{CH}_3)_2$)CO $_2$ CH $_3$), 5.39-4.43 (1H, dd, $J_A=5.92\text{Hz}$, $J_B=4.92\text{Hz}$, PhCH $_2$ CH(OCOCH $_3$)CO-), 6.32 (1H, d, $J=8.36\text{Hz}$, -NH), 7.16-7.29 (5H, m, ArH).

^{13}C -n.m.r.(100MHz) δ (CDCl_3): 173.07 (-NHCH($\text{CH}_2\text{CH}(\text{CH}_3)_2$)CO $_2$ CH $_3$), 169.27, 168.24 (PhCH $_2$ CH(OCOCH $_3$)CO- and PhCH $_2$ CH(OCOCH $_3$)CO-), 135.65, 129.64, 128.31, 126.90 (aromatic carbons), 74.14 (PhCH $_2$ CH(OCOCH $_3$)CO-), 52.33 (-NHCH($\text{CH}_2\text{CH}(\text{CH}_3)_2$)CO $_2$ CH $_3$), 50.22 (-NHCH($\text{CH}_2\text{CH}(\text{CH}_3)_2$)CO $_2$ CH $_3$), 41.59

(-NHCH(CH₂CH(CH₃)₃)CO₂CH₃), 37.40 (PhCH₂CH(OCOCH₃)CO-), 24.48,
(-NHCH(CH₂CH(CH₃)₂)CO₂CH₃), 22.69, 21.87 (-NHCH(CH₂CH(CH₃)₂)CO₂CH₃), 20.93
(PhCH₂CH(OCOCH₃)CO-).

Note: The signals at 169.27 and 168.24 may be interchangeable.

N-((*S*)-2-Hydroxy-3-phenylpropionyl)-L-leucine (21c)

1M NaOH (25ml) was added to a solution of *N*-((*S*)-2-acetoxy-3-phenylpropionyl)-L-leucine methyl ester (3.35g, 0.01mol) in methanol (20ml) and allowed to stir at room temperature for 1hr. The solution was cooled to 0°C and acidified with 10% hydrochloric acid. The methanol was removed *in vacuo* and the solution allowed to cool. The resultant white precipitate was filtered and recrystallized from acetone/*n*-hexane to yield the title compound as a white rhombs (2.35g, 84%).

m.p. 126-128°C (uncorrected).

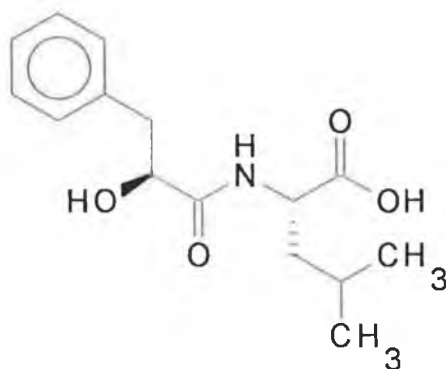

Spectroscopic analysis

i.r. ν_{\max} (KBr): 3390 (OH), 3065, 1732 (carboxylic acid C=O), 1651 (amide C=O), 1539, 1261, 1187, 1146cm⁻¹.

¹H-n.m.r.(400MHz) δ (DMSO): 0.81 (6H, dd, $J_A=10.8\text{Hz}$, $J_B=5.92\text{Hz}$,

-NHCH(CH₂CH(CH₃)₂)CO₂H), 1.35-1.57 (3H, m, -NHCH(CH₂CH(CH₃)₂)CO₂H and

-CH₂CH(CH₃)₂), 2.73 (1H, dd, J_A=13.76Hz, J_B=7.88Hz, PhCH₂CH(OH)CO-) & 2.96 (1H, dd, J_A=13.76Hz, J_B=3.44Hz, PhCH₂CH(OH)CO-), 4.12 (1H, m, PhCH₂CH(OH)CO-), 4.23-4.29 (1H, m, -NHCH(CH₂CH(CH₃)₂)-), 5.69 (1H, d, J=4.9Hz, PhCH₂CH(OH)CO-) 7.14-7.26 (5H, m, ArH), 7.65 (1H, d, J=8.36Hz, -NH), 12.64 (1H, s, -NHCH(CH₂CH(CH₃)₂)CO₂H).

¹³C-n.m.r.(100MHz)δ(DMSO): 173.92, 173.00 (PhCH₂CH(OH)CO- and -NHCH(CH₂CH(CH₃)₂)CO₂H), 138.27, 129.58, 127.85, 125.98 (aromatic carbons), 71.85 (PhCH₂CH(OH)CO-), 49.60 (-NHCH(CH₂CH(CH₃)₂)CO₂H), 24.08 (-NHCH(CH₂CH(CH₃)₂)CO₂H), 22.90, 21.38 (-NHCH(CH₂CH(CH₃)₂)CO₂H).

Note: The PhCH₂CH(OH)CO- and -NHCH(CH₂CH(CH₃)₂)CO₂H signals are obscured by the DMSO signal.

Mass spectrum: [M-H₂O]⁺ found 261.1264 C₁₅H₁₉NO₃ requires 261.13633.

m/z (%): 261 (3) [M-H₂O]⁺, 205 (84), 131 (93), 91 (29), 103 (41), 86 (60) (immonium ion of Leu).

N-((S)-2-Acetoxy-3-phenylpropionyl)-L-phenylalanine methyl ester (20d)

Dicyclohexylcarbodiimide (2.1g, 0.01mol) was added to a solution of *O*-acetyl-L-α-phenyllactic acid (2.1g, 0.01mol), L-phenylalanine methyl ester hydrochloride (2.16g, 0.01mol) and dry pyridine (1.6ml, 0.02mol) in dichloromethane (100ml) at 0°C. After 30min the reaction temperature was raised to room temperature and the reaction allowed to proceed for 6hr. The precipitate of dicyclohexylurea was removed by filtration. The filtrate was washed with 10% sodium hydrogen carbonate, 5% hydrochloric acid, water and dried. The solvent was removed *in vacuo* and the resultant oil purified by flash chromatography on silica gel [petroleum ether 40-60/ethyl acetate (7:3)] yielding the title compound as white needles. (3.21g, 87%).

m.p. 64-66°C (uncorrected)

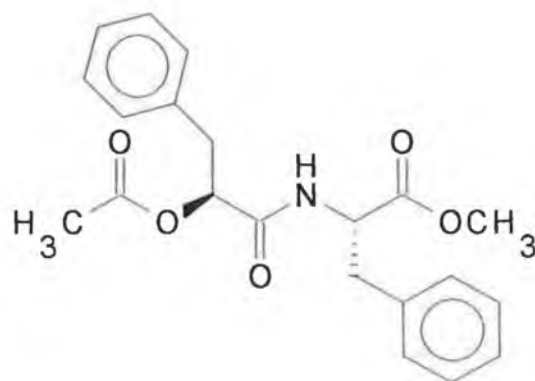

Spectroscopic analysis

i.r. ν_{\max} (KBr): 3313 (NH), 1730 (ester/acetate C=O), 1653 (amide C=O), 1540, 1445, 1353, 1250, 1223, 1206, 979.57 cm^{-1} .

^1H -n.m.r.(400MHz) δ (CDCl_3): 2.02 (3H, s, $\text{PhCH}_2\text{CH}(\text{OCOCH}_3)\text{CO-}$), 2.92 (1H, dd, $J_A=13.76\text{Hz}$, $J_B=5.92\text{Hz}$, $\text{PhCH}_2\text{CH}(\text{OCOCH}_3)\text{CO-}$), 3.04-3.21 (3H, m, $\text{PhCH}_2\text{CH}(\text{OCOCH}_3)\text{CO-}$ and $-\text{NHCH}(\text{CH}_2\text{Ph})\text{CO}_2\text{CH}_3$), 3.68 (3H, s, $-\text{NHCH}(\text{CH}_2\text{Ph})\text{CO}_2\text{CH}_3$), 4.83-4.88 (1H, m, $-\text{NHCH}(\text{CH}_2\text{Ph})\text{CO}_2\text{CH}_3$), 5.35-5.40 (1H, m, $\text{PhCH}_2\text{CH}(\text{OCOCH}_3)\text{CO-}$), 6.41 (1H, d, $J=7.88\text{Hz}$, $-\text{NH}$), 6.82-7.32 (10H, m, ArH).

^{13}C -n.m.r.(100MHz) δ (CDCl_3): 171.33 ($-\text{NHCH}(\text{CH}_2\text{Ph})\text{CO}_2\text{CH}_3$), 169.20, 168.30 ($\text{PhCH}_2\text{CH}(\text{OCOCH}_3)\text{CO-}$ and $\text{PhCH}_2\text{CH}(\text{OCOCH}_3)\text{CO-}$), 135.66, 135.26, 129.69, 129.23, 128.43, 128.35, 127.10, 127.02 (aromatic carbons), 73.96 ($\text{PhCH}_2\text{CH}(\text{OCOCH}_3)\text{CO-}$), 52.41 ($-\text{NHCH}(\text{CH}_2\text{Ph})\text{CO}_2\text{CH}_3$), 52.29 ($-\text{NHCH}(\text{CH}_2\text{Ph})\text{CO}_2\text{CH}_3$), 37.82, 37.39 ($-\text{NHCH}(\text{CH}_2\text{Ph})\text{CO}_2\text{CH}_3$ and $\text{PhCH}_2\text{CH}(\text{OCOCH}_3)\text{CO-}$), 20.74 ($\text{PhCH}_2\text{CH}(\text{OCOCH}_3)\text{CO-}$).

Note: The signals at 169.20 and 168.30 may be interchangeable. The signals at 37.82 and 37.39 may also be interchangeable.

N-((*S*)-2-Hydroxy-3-phenylpropionyl)-*L*-phenylalanine (21d)

1M NaOH (25ml) was added to a solution of *N*-((*S*)-2-acetoxy-2-phenylpropionyl)-*L*-phenylalanine methyl ester (3.69g, 0.01mol) in methanol (20ml) and allowed to stir at room temperature for 1hr. The solution was cooled to 0°C and acidified with 10% hydrochloric acid. The methanol was removed *in vacuo* and the solution allowed to cool. The resultant white precipitate was filtered and recrystallized from acetone/*n*-hexane furnishing the title compound as a white rhombs (3.14g, 92%).

m.p. 156-158°C (uncorrected).

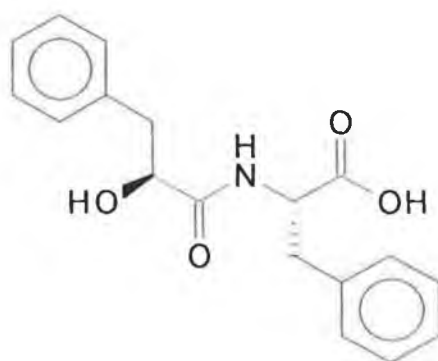

Spectroscopic analysis

i.r. ν_{\max} (KBr): 3376 (OH), 1737 (carboxylic acid C=O), 1711, 1609, 1533, 1496, 1230, 1223, 1199, 1130, 1086 cm^{-1} .

^1H -n.m.r.(400MHz) δ (DMSO): 2.59 (1H, dd, $J_{\text{A}}=13.8\text{Hz}$, $J_{\text{B}}=8.4\text{Hz}$, $\text{PhCH}_2\text{CH}(\text{OH})\text{CO}-$), 2.87 (1H, dd, $J_{\text{A}}=13.8\text{Hz}$, $J_{\text{B}}=2.96\text{Hz}$, $\text{PhCH}_2\text{CH}(\text{OH})\text{CO}-$), 2.98 (2H, d, $J=6.4\text{Hz}$, $-\text{NHCH}(\text{CH}_2\text{Ph})\text{CO}_2\text{H}$), 4.05 (1H, m, $\text{PhCH}_2\text{CH}(\text{OH})\text{CO}-$), 4.54-4.56 (1H, m, $-\text{NHCH}(\text{CH}_2\text{Ph})\text{CO}_2\text{H}$), 5.72 (1H, d, $J=5.4\text{Hz}$, $\text{PhCH}_2\text{CH}(\text{OH})\text{CO}-$), 7.03-7.27 (10H, m, ArH), 7.66 (1H, d, $J=8.4\text{Hz}$, $-\text{NH}$).

^{13}C -n.m.r.(100MHz) δ (DMSO): 172.90, 172.61 (-NHCH(CH₂Ph)CO₂H and PhCH₂CH(OH)CO-), 138.39, 137.01, 129.56, 129.27, 128.18, 127.95, 126.52, 126.07 (aromatic carbons), 71.94 (PhCH₂CH(OH)CO-), 52.35 (-NHCH(CH₂Ph)CO₂H), 40.34 (-NHCH(CH₂Ph)CO₂H), 36.75 (PhCH₂CH(OH)CO-).

Mass spectrum: [M-H₂O]⁺⁺ found: 295.120844 C₁₈H₁₇NO₃ requires 295.12069.

m/z (%): 295 (6) [M-H₂O]⁺⁺, 251 (3), 131 (40), 120 (27) (immonium ion of Phe), 103 (29), 91 (100).

N-((*S*)-2-acetoxy-3-phenylpropionyl) phenethylamide (20e)

Dicyclohexylcarbodiimide (2.1g, 0.01mol) was added to a solution of *O*-acetyl-*L*- α -phenyllactic acid (2.1g, 0.01mol), phenethylamine (1.26ml, 0.01mol) and dry pyridine (1.6ml, 0.02mol) in dichloromethane (100ml) at 0°C. After 30min the reaction temperature was increased to room temperature and the reaction allowed to proceed for 6hr. The precipitate of dicyclohexylurea was then removed by filtration. The filtrate was washed with 10% sodium hydrogen carbonate, 5% hydrochloric acid, water and dried. the solvent was removed *in vacuo* and the resultant oil purified by flash chromatography on silica gel [petroleum ether 40-60/ethyl acetate (7:3)] to yield the title compound as a colourless oil (2.83g, 92%).

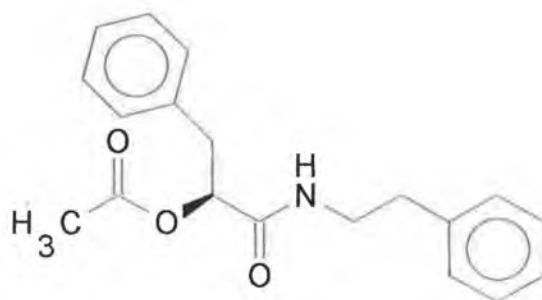

Spectroscopic analysis

i.r. ν_{\max} (CHCl₃): 3308 (NH), 2933, 1743 (acetate C=O), 1654 (amide C=O), 1534, 1497, 1455, 1437, 1372, 1230, 1080, 1046cm⁻¹.

¹H-n.m.r.(400MHz) δ (CDCl₃): 1.96 (3H, s, PhCH₂CH(OCOCH₃)CO-), 2.63-2.75 (2H, m, -NHCH₂CH₂Ph), 3.10 (1H, dd, J_A=14.2Hz, J_B=6.4Hz, PhCH₂CH(OCOCH₃)CO-), 3.18 (1H, dd, J_A=14.2Hz, J_B=4.92Hz, PhCH₂CH(OCOCH₃)CO-), 3.42-3.47 (2H, t, J=5.9Hz, -NHCH₂CH₂Ph), 5.33 (1H, m, PhCH₂CH(OCOCH₃)CO-), 6.01 (1H, m, -NH), 7.02-7.30 (10H, m, ArH).

¹³C-n.m.r.(100MHz) δ (CDCl₃): 169.15, 168.69 (PhCH₂CH(OCOCH₃)CO- and PhCH₂CH(OCOCH₃)CO-), 138.39, 135.72, 129.47, 128.62, 128.44, 128.20, 126.80, 126.39 (aromatic carbons), 74.10 (PhCH₂CH(OCOCH₃)CO-), 40.00 (-NHCH₂CH₂Ph), 37.49, (PhCH₂CH(OCOCH₃)CO-) 35.31 (-NHCH₂CH₂Ph), 20.64 (PhCH₂CH(OCOCH₃)CO-).

N-((*S*)-2-Hydroxy-3-phenylpropionyl) phenethylamide (21e)

1M NaOH (25ml) was added to a solution of *N*-((*S*)-2-acetoxy-3-phenylpropionyl) phenethylamide (3.1g, 0.01mol) in methanol (20ml) and stirred at room temperature for 1hr. The solution was cooled to 0°C and acidified with 10% hydrochloric acid. The methanol was removed *in vacuo* and the solution cooled. The resultant white precipitate was filtered and recrystallized from acetone/*n*-hexane to yield the title compound¹⁶¹ as a white crystalline solid (2.4g, 89%).

m.p. 96-98°C (uncorrected).

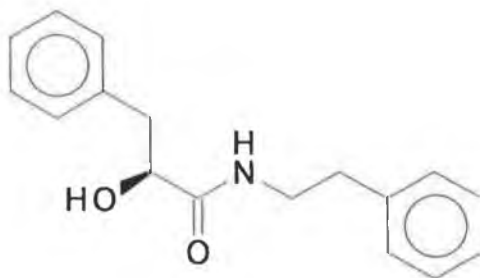

Spectroscopic analysis

i.r. ν_{\max} (KBr): 3351 (OH), 3029, 1643 (amide C=O), 1547, 1496, 1454, 1398, 1308, 1084, 1067 cm^{-1} .

^1H -n.m.r.(400MHz) δ (DMSO): 2.64-2.7 (3H, m, $\text{PhCH}_2\text{CH}(\text{OH})\text{CO}$ - and $-\text{NHCH}_2\text{CH}_2\text{Ph}$), 2.94 (1H, dd, $J_A=13.8\text{Hz}$, $J_B=3.44\text{Hz}$, $\text{PhCH}_2\text{CH}(\text{OH})\text{CO}$ -), 3.24-3.33 (2H, m, $-\text{NHCH}_2\text{CH}_2\text{Ph}$), 4.03 (1H, m, $\text{PhCH}_2\text{CH}(\text{OH})\text{CO}$ -), 5.56 (1H, d, $J=5.9\text{Hz}$, $\text{PhCH}_2\text{CH}(\text{OH})\text{CO}$ -), 7.14-7.29 (10H, m, ArH), 7.76 (1H, t, $J=5.9\text{Hz}$, -NH).

^{13}C -n.m.r.(100MHz) δ (DMSO): 173.12 ($\text{PhCH}_2\text{CH}(\text{OH})\text{CO}$ -), 139.40, 138.59, 129.49, 128.60, 128.33, 127.90, 126.08, 125.97 (aromatic carbons), 72.18 ($\text{PhCH}_2\text{CH}(\text{OH})\text{CO}$ -), 40.41 ($-\text{NHCH}_2\text{CH}_2\text{Ph}$), 35.21 ($-\text{NHCH}_2\text{CH}_2\text{Ph}$).

Note: The $\text{PhCH}_2\text{CH}(\text{OH})\text{CO}$ - signal is obscured by the DMSO signal.

N-((R/S)-3-Acetoxy-3-phenylpropionyl) glycine methyl ester (25a)

Dicyclohexylcarbodiimide (2.1g, 0.01mol) was added to a solution of *O*-acetyl-D/L- β -phenyllactic acid (2.1g, 0.01mol), glycine methyl ester hydrochloride (1.26g, 0.01mol) and dry pyridine (1.6ml, 0.02mol) in dichloromethane (100ml) at 0°C. After 30min the reaction temperature was increased to room temperature and the reaction allowed to proceed for 6hr. The precipitate of dicyclohexylurea was then removed by filtration. The filtrate was washed with 10% sodium hydrogen carbonate, 5% hydrochloric acid, water and dried. The solvent was removed *in vacuo*. Recrystallization of the resulting oil from ethyl acetate/pet ether 40-60 yielded the title compound as a waxy solid (1.34g, 48%).

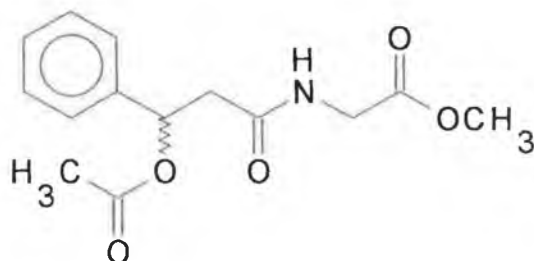

Spectroscopic analysis

i.r. ν_{\max} (KBr): 3338 (NH), 1741 (ester/acetate C=O), 1645 (amide C=O), 1379, 1270, 1246, 1167, 1027 cm^{-1} .

^1H -n.m.r.(400MHz) δ (CDCl_3): 2.05 (6H, s, $\text{PhCH}(\text{OCOCH}_3)\text{CH}_2\text{CO-}$), 2.75 (4H, m, $\text{PhCH}(\text{OCOCH}_3)\text{CH}_2\text{CO-}$), 3.73 (4H, s, $-\text{NHCH}_2\text{CO}_2\text{CH}_3$), 3.98 (4H, d, $J=7\text{Hz}$, $-\text{NHCH}_2\text{CO}_2\text{CH}_3$), 6.14 (2H, m, $\text{PhCH}(\text{OCOCH}_3)\text{CH}_2\text{CO-}$), 6.22 (2H, t, $J=7\text{Hz}$, NH), 7.25-7.36 (10H, m, ArH)

^{13}C -n.m.r.(100MHz) δ (CDCl_3): 173.41 ($-\text{NHCH}_2\text{CO}_2\text{CH}_3$), 169.62, 168.33 ($\text{PhCH}(\text{OCOCH}_3)\text{CH}_2\text{CO-}$ and $\text{PhCH}(\text{OCOCH}_3)\text{CH}_2\text{CO-}$), 139.45, 128.56, 128.23, 126.22

(aromatic carbons), 72.74 (PhCH(OCOCH₃)CH₂CO-), 52.34 (-NHCH₂CO₂CH₃), 43.40 (PhCH(OCOCH₃)CH₂CO-), 40.67 (-NHCH₂CO₂CH₃), 20.99 (PhCH(OCOCH₃)CH₂CO-)

N-((*R/S*)-3-Hydroxy-3-phenylpropionyl) glycine (26a)

1M NaOH (25ml) was added to a solution of *N*-((*R/S*)-2-acetoxy-2-phenylpropionyl) glycine methyl ester (2.8g, 0.01mol) in methanol (20ml) and allowed to stir at room temperature for 1hr. The solution was then cooled to 0°C and acidified with 10% hydrochloric acid. The solvent was evaporated and the solid extracted with acetone. The solvent was removed *in vacuo*. The resultant solid was filtered and recrystallized from acetone/*n*-hexane to yield the title compound as a white crystalline solid (1.83g, 82%) m.p. 140-142°C.

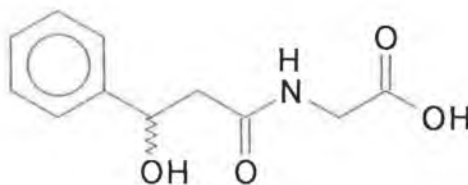

Spectroscopic analysis

i.r. ν_{\max} (KBr): 3283 (OH), 3108, 1706 (carboxylic acid C=O), 1591, 1448, 1420, 1348, 1264, 1196, 1106, 1044cm⁻¹.

¹H-n.m.r.(400MHz) δ (DMSO): 2.40 (2H, dd, $J_A=14.76\text{Hz}$, $J_B=4.5\text{Hz}$, PhCH(OH)CH₂CO-), 3.75 (4H, d, $J=5.7\text{Hz}$, -NHCH₂CO₂H), 4.96 (2H, dd, $J_A=8.84\text{Hz}$, $J_B=4.5\text{Hz}$, PhCH(OH)CH₂CO-), 7.19-7.63 (10H, m, ArH), 8.20 (2H, t, $J=5.7\text{Hz}$, -NH).

Note: The second PhCH(OH)CH₂CO- signal is obscured by the DMSO signal.

^{13}C -n.m.r.(100MHz) δ (DMSO): 171.38, 170.57 (-NHCH $\underline{\text{C}}$ O $\underline{\text{C}}$ H and PhCH(OH)CH $\underline{\text{C}}$ O-), 145.36, 128.99, 128.05, 126.85, 125.70 (aromatic carbons), 69.51 (PhCH(OH)CH $\underline{\text{C}}$ O-), 45.46 (-NHCH $\underline{\text{C}}$ O $\underline{\text{C}}$ H), 40.46 (PhCH(OH)CH $\underline{\text{C}}$ O-).

Mass spectrum: $[\text{M}+\text{H}]^+$ found 223.8581 $\text{C}_{11}\text{H}_{14}\text{NO}_4$ requires 224.09215

N-((*R/S*)-3-Acetoxy-3-phenylpropionyl)-*L*-alanine methyl ester (25b)

Dicyclohexylcarbodiimide (2.1g, 0.01mol) was added to a solution of *O*-acetyl-*D/L*- β -phenyllactic acid (2.1g, 0.01mol), *L*-alanine methyl ester hydrochloride (1.4g, 0.01mol) and dry pyridine (1.6ml, 0.02mol) in dichloromethane (100ml) at 0°C. After 30min the reaction temperature was increased to room temperature and the reaction allowed to proceed for 6hr. The precipitate of dicyclohexylurea was then removed by filtration. The filtrate was washed with 10% sodium hydrogen carbonate, 5% hydrochloric acid, water and dried. The solvent was removed *in vacuo* and recrystallization from ethyl acetate/pet ether 40-60 yielded the title compound a white crystalline solid (1.23g, 42%).

m.p. 124-126°C (uncorrected).

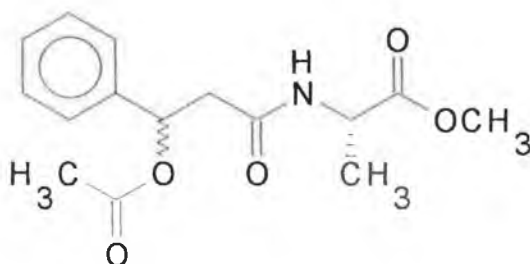

Spectroscopic analysis

i.r. ν_{max} (KBr): 3341 (NH), 1740, 1711 (ester/ acetate C=O), 1683 (amide C=O), 1548, 1460, 1380, 1263, 1243, 1209, 1152, 1029 cm^{-1} .

^1H -n.m.r.(400MHz) δ (CDCl_3): 1.30 (6H, d, $J=6.88\text{Hz}$, $-\text{NHCH}(\underline{\text{CH}_3})\text{CO}_2\text{CH}_3$), 2.09 (6H, s, $\text{PhCH}(\text{OCOCH}_3)\text{CH}_2\text{CO}-$), 2.64 (2H, dd, $J_A=14.5\text{Hz}$, $J_B=4.92\text{Hz}$, $\text{PhCH}(\text{OCOCH}_3)\underline{\text{CH}_2}\text{CO}-$), 2.86 (2H, dd, $J_A=14.5\text{Hz}$, $J_B=8.84\text{Hz}$, $\text{PhCH}(\text{OCOCH}_3)\underline{\text{CH}_2}\text{CO}-$), 3.74 (6H, s, $-\text{NHCH}(\text{CH}_3)\text{CO}_2\underline{\text{CH}_3}$), 4.55-4.59 (2H, m, $-\text{NHCH}(\text{CH}_3)\text{CO}_2\text{CH}_3$), 6.12-6.16 (2H, m, $\text{PhCH}(\text{OCOCH}_3)\text{CH}_2\text{CO}-$), 6.22 (2H, d, $J=6.88\text{Hz}$, $-\text{NH}$), 7.26-7.36 (10H, m, ArH).

^{13}C -n.m.r.(100MHz) δ (CDCl_3): 173.36 ($-\text{NHCH}(\text{CH}_3)\underline{\text{CO}}_2\text{CH}_3$), 169.75, 168.33 ($\text{PhCH}(\underline{\text{OCO}}\text{CH}_3)\text{CH}_2\text{CO}-$ and $\text{PhCH}(\text{OCOCH}_3)\underline{\text{CH}_2}\text{CO}-$), 139.44, 128.58, 128.24, 126.23 (aromatic carbons), 72.63 ($\text{PhCH}(\text{OCOCH}_3)\text{CH}_2\text{CO}-$), 52.46 ($-\text{NHCH}(\text{CH}_3)\text{CO}_2\underline{\text{CH}_3}$), 47.91 ($-\text{NHCH}(\text{CH}_3)\text{CO}_2\text{CH}_3$), 43.70 ($\text{PhCH}(\text{OCOCH}_3)\underline{\text{CH}_2}\text{CO}-$), 21.04 ($\text{PhCH}(\text{OCO}\underline{\text{CH}_3})\text{CH}_2\text{CO}-$), 18.33 ($-\text{NHCH}(\underline{\text{CH}_3})\text{CO}_2\text{CH}_3$).

Mass spectrum: $[\text{M}+\text{H}]^+$ found 294.0253 $\text{C}_{15}\text{H}_{18}\text{NO}_5$ requires 294.13397

Attempted synthesis of *N*-((*R/S*)-3-hydroxy-3-phenylpropionyl)-L-alanine

1M NaOH (25ml), was added to a solution of *N*-((*R/S*)-2-acetoxy-2-phenylpropionyl)-L-alanine methyl ester (2.93g, 0.01mol) in methanol (20ml) and allowed to stir at room temperature for 1hr. The solution was then cooled to 0°C and acidified with 10% hydrochloric acid. The solvent was evaporated, and the residue extracted with acetone. The solvent was removed *in vacuo*. Attempted purification of the resultant yellow oil by flash chromatography [chloroform/methanol (95:5)] did not yield the desired product and the reaction was not investigated further.

Attempted synthesis of *N*-((*R/S*)-3-acetoxy-3-phenylpropionyl)-L-leucine methyl ester (25c)

Dicyclohexylcarbodiimide (2.1g, 0.01mol) was added to a solution of *O*-acetyl-*D/L*- β -phenyllactic acid (2.1g, 0.01mol), L-leucine methyl ester hydrochloride (1.81g, 0.01mol)

and dry pyridine (1.6ml, 0.02mol) in dichloromethane (100ml) at 0°C. After 30min the reaction temperature was raised to room temperature and the reaction continued for 6hr. The precipitate of dicyclohexylurea was removed by filtration. The filtrate was washed with 10% sodium hydrogen carbonate, 5% hydrochloric acid, water and dried. The solvent was removed *in vacuo*. Attempted purification of the resultant oil by flash chromatography [petroleum ether 40-60/ethyl acetate (6:4)] did not yield the desired product and the reaction was not investigated further.

N-((R/S)-3-Acetoxy-3-phenylpropionyl)-L-phenylalanine methyl ester (25c)

Dicyclohexylcarbodiimide (2.1g, 0.01mol) was added to a solution of *O*-acetyl-D/L- β -phenyllactic acid (2.1g, 0.01mol), L-phenylalanine methyl ester hydrochloride (2.16g, 0.01mol) and dry pyridine (1.6ml, 0.02mol) in dichloromethane (100ml) at 0°C. After 30min the reaction temperature was raised to room temperature and the reaction continued for 6hr. The precipitate of dicyclohexylurea was removed by filtration. The filtrate was washed with 10% sodium hydrogen carbonate, 5% hydrochloric acid, water and dried. The solvent was removed *in vacuo* and the resultant oil recrystallized from ethyl acetate/pet ether to give the title compound as a white crystalline solid.

m.p. 104-106°C (uncorrected).

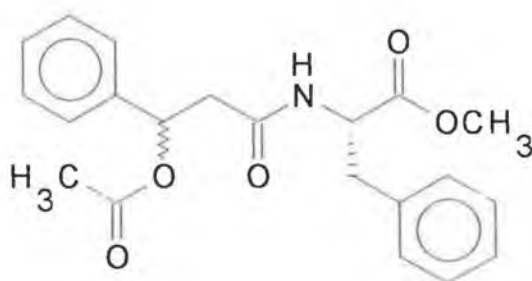

Spectroscopic analysis

i.r. ν_{\max} (KBr): 3333 (NH), 1742 (ester/acetate C=O), 1643 (amide C=O), 1543, 1494, 1454, 1433, 1374, 1352, 1281, 1244, 1178, 1120 cm^{-1} .

^1H -n.m.r.(400MHz) δ (CDCl_3): 2.00 (6H, s, $\text{PhCH}(\text{OCOCH}_3)\text{CH}_2\text{CO-}$), 2.65 (2H, dd, $J_A=14.8\text{Hz}$, $J_B=4.44\text{Hz}$, $\text{PhCH}(\text{OCOCH}_3)\text{CH}_2\text{CO-}$), 2.82 (2H, dd, $J_A=14.8\text{Hz}$, $J_B=8.8\text{Hz}$, $\text{PhCH}(\text{OCOCH}_3)\text{CH}_2\text{CO-}$), 3.05-3.18 (4H, m, $-\text{NHCH}(\text{CH}_2\text{Ph})\text{CO}_2\text{CH}_3$), 3.70 (6H, s, $-\text{NHCH}(\text{CH}_2\text{Ph})\text{CO}_2\text{CH}_3$), 4.82-4.88 (2H, m, $-\text{NHCH}(\text{CH}_2\text{Ph})\text{CO}_2\text{CH}_3$), 6.09-6.15 (4H, m, $\text{PhCH}(\text{OCOCH}_3)\text{CH}_2\text{CO-}$ and $-\text{NH}$), 7.07 (20H, m, ArH).

^{13}C -n.m.r.(100MHz) δ (CDCl_3): 171.76 ($-\text{NHCH}(\text{CH}_2\text{Ph})\text{CO}_2\text{CH}_3$), 169.63, 168.42 ($\text{PhCH}(\text{OCOCH}_3)\text{CH}_2\text{CO-}$ and $\text{PhCH}(\text{OCOCH}_3)\text{CH}_2\text{CO-}$), 139.39, 135.74, 129.15, 128.56, 128.23, 127.11, 126.35, 126.20 (aromatic carbons), 72.57 ($\text{PhCH}(\text{OCOCH}_3)\text{CH}_2\text{CO-}$), 53.17 ($-\text{NHCH}(\text{CH}_2\text{Ph})\text{CO}_2\text{CH}_3$), 52.31 ($-\text{NHCH}(\text{CH}_2\text{Ph})\text{CO}_2\text{CH}_3$), 43.34 ($-\text{NHCH}(\text{CH}_2\text{Ph})\text{CO}_2\text{CH}_3$), 37.06 ($\text{PhCH}(\text{OCOCH}_3)\text{CH}_2\text{CO-}$), 21.02 ($\text{PhCH}(\text{OCOCH}_3)\text{CH}_2\text{CO-}$).

N-((*R/S*)-3-Hydroxy-3-phenylpropionyl)-*L*-phenylalanine (26b)

1M NaOH (25ml) was added to a solution of *N*-((*R/S*)-3-acetoxy-3-phenylpropionyl)-*L*-phenylalanine methyl ester (3.69g, 0.01mol) in methanol (20ml) and allowed to stir at room temperature for 1hr. The solution was then cooled to 0°C and acidified with 10% hydrochloric acid. The methanol was removed *in vacuo* and the solution allowed to cool. The resultant white precipitate was filtered and recrystallized from acetone/*n*-hexane yielding the title compound as a white crystalline solid
m.p. 130-132°C (uncorrected).

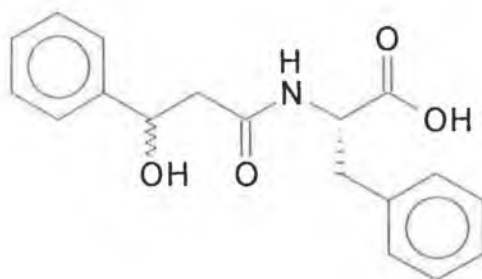

Spectroscopic analysis

i.r. ν_{\max} (KBr): 3384 (OH), 3334 (NH), 1736 (carboxylic acid C=O), 1707, 1638 (amide C=O), 1529, 1494, 1452, 1430, 1409, 1373, 1347, 1263, 1235 cm^{-1} .

^1H -n.m.r.(400MHz) δ (DMSO): 2.32-2.41 (2H, m, PhCH(OH)CH₂CO-), 2.80-2.91 (2H, m, -NHCH(CH₂Ph)CO₂H), 2.95-3.06 (2H, m, -NHCH(CH₂Ph)CO₂H), 4.40-4.48 (2H, m, -NHCH(CH₂Ph)CO₂H), 4.90 (2H, dd, $J_A=8.36\text{Hz}$, $J_B=5.4\text{Hz}$, PhCH(OH)CH₂CO-), 7.12-7.30 (20H, m, ArH), 8.16-8.21 (2H, m, -NH).

Note: Second PhCH(OH)CH₂CO- signal is obscured by the DMSO signal.

^{13}C -n.m.r.(100MHz) δ (DMSO): 172.92 170.04 (-NHCH(CH₂Ph)CO₂H and PhCH(OH)CH₂CO-), 145.23, 145.20, 137.56, 129.19, 129.11, 128.22, 128.16, 127.99, 126.82, 126.79, 126.44, 126.40, 125.75, 125.69 (aromatic carbons), 69.53, 69.47 (PhCH(OH)CH₂CO-), 53.51, 53.31 (-NHCH(CH₂Ph)CO₂H), 45.38, 45.28 (-NHCH(CH₂Ph)CO₂H), 36.95, 36.83 (PhCH(OH)CH₂CO-).

Mass spectrum: $[\text{M}+\text{H}]^+$ found: 314.0065 $\text{C}_{18}\text{H}_{20}\text{NO}_4$ requires 314.13907, $[\text{M}+\text{Na}]^+$ found 335.98417 $\text{C}_{18}\text{H}_{19}\text{NO}_4\text{Na}$ requires 336.12125, $[\text{M}+\text{H}-\text{H}_2\text{O}]^+$ found 296.0165 $\text{C}_{18}\text{H}_{18}\text{NO}_3$ requires 296.12853

N-((*R/S*)-3-Acetoxy-3-phenylpropionyl) phenethylamide (25d)

Dicyclohexylcarbodiimide (2.1g, 0.01mol) was added to a solution of *O*-acetyl- β -L-phenyllactic acid (2.1g, 0.01mol), phenethylamine (1.26ml, 0.01mol) and dry pyridine (1.6ml, 0.02mol) in dichloromethane (100ml) at 0°C. After 30min the reaction temperature was raised to room temperature and the reaction continued for 6hr. The precipitate of dicyclohexylurea was removed by filtration. The filtrate was washed with 10% sodium hydrogen carbonate, 5% hydrochloric acid, water and dried. The solvent was removed *in vacuo* and the resultant oil purified by flash chromatography on silica gel [petroleum ether 40-60/ethyl acetate (6:4)] to yield the title compound as a white waxy solid.

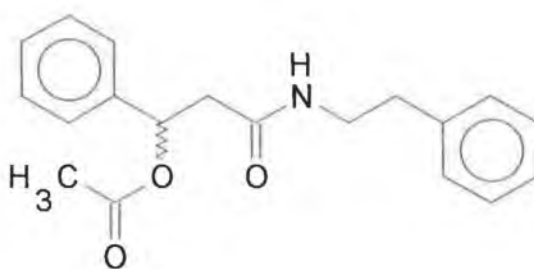

Spectroscopic analysis

i.r. ν_{\max} (CHCl₃): 3388 (NH), 1740 (acetate C=O), 1651 (amide C=O), 1552, 1496, 1455, 1372, 1233, 1166, 1024cm⁻¹.

¹H-n.m.r.(400MHz) δ (CDCl₃): 1.98 (6H, s, PhCH(OCOCH₃)CH₂CO-), 2.55 (2H, dd, J_A=14.28Hz, J_B=5.4Hz, PhCH(OCOCH₃)CH₂CO-), 2.67-2.79 (6H, m, -NHCH₂CH₂Ph and PhCH(OCOCH₃)CH₂CO-), 3.39-3.47 (4H, m, -NHCH₂CH₂Ph), 6.00 (2H, t, 5.66Hz, -NH), 6.14, (2H, dd, J_A=8.88Hz, J_B=5.92Hz, PhCH(OCOCH₃)CH₂CO-), 7.05-7.31 (20H, m, ArH).

^{13}C -n.m.r.(100MHz) δ (CDCl_3): 169.60, 168.75 ($\text{PhCH}(\text{OCOCH}_3)\text{CH}_2\text{CO-}$ and $\text{PhCH}(\text{OCOCH}_3)\text{CH}_2\text{CO-}$), 139.48, 138.60, 128.48, 128.40, 128.36, 128.10, 126.27, 126.16, (aromatic carbons), 72.71 ($\text{PhCH}(\text{OCOCH}_3)\text{CH}_2\text{CO-}$), 43.45 ($-\text{NHCH}_2\text{CH}_2\text{Ph}$), 40.45 ($-\text{NHCH}_2\text{CH}_2\text{Ph}$), 35.30 ($-\text{PhCH}(\text{OCOCH}_3)\text{CH}_2\text{CO-}$), 20.89 ($\text{PhCH}(\text{OCOCH}_3)\text{CH}_2\text{CO-}$)

N-((*R/S*)-3-Hydroxy-3-phenylpropionyl) phenethylamide (26c)

1M NaOH (25ml) was added to a solution of *N*-((*R/S*)-3-acetoxy-3-phenylpropionyl) phenethylamide (3.1g, 0.01mol) in methanol (20ml) and stirred at room temperature for 1hr. The solution was then cooled to 0°C and acidified with 10% hydrochloric acid. The methanol was removed *in vacuo* and the solution allowed to cool. The resultant white precipitate was filtered and recrystallized from acetone/*n*-hexane to furnish the title compound as a white crystalline solid

m.p. $144\text{-}146^\circ\text{C}$ (uncorrected).

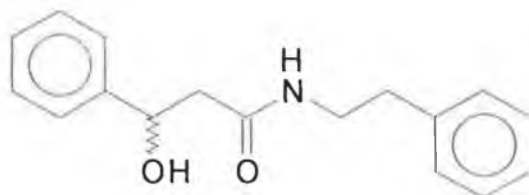

Spectroscopic analysis

i.r. ν_{max} (KBr): 3396 (OH), 3314 (NH), 1644 (amide C=O), 1551, 1496, 1460, 1452, 1409, 1196, 1063cm^{-1} .

^1H -n.m.r.(400MHz) δ (DMSO): 2.33 (2H, dd, $J_{\text{A}}=14.24\text{Hz}$, $J_{\text{B}}=4.92\text{Hz}$, $\text{PhCH}(\text{OH})\text{CH}_2\text{CO-}$), 2.43 (2H, dd, $J_{\text{A}}=14.24\text{Hz}$, $J_{\text{B}}=8.36\text{Hz}$, $\text{PhCH}(\text{OH})\text{CH}_2\text{CO-}$), 2.65 (4H, t, $J=7.38\text{Hz}$, $-\text{NHCH}_2\text{CH}_2\text{Ph}$), 3.16-3.29 (4H, m, $-\text{NHCH}_2\text{CH}_2\text{Ph}$), 4.92-4.97 (2H, m,

PhCH(OH)CH₂CO-, 5.38 (2H, d, J=4.44Hz, PhCH(OH)CH₂CO-), 7.15-7.32 (20H, m, ArH), 7.92 (2H, t, J=5.4Hz, -NH).

¹³C-n.m.r.(100MHz)δ(DMSO): 170.01 (PhCH(OH)CH₂CO-), 145.37, 139.50, 128.60, 128.29, 127.99, 126.79, 126.01, 125.69 (aromatic carbons), 69.66 (PhCH(OH)CH₂CO-), 45.70 (-NHCH₂CH₂Ph), 35.18 (PhCH(OH)CH₂CO-).

Note: The -NHCH₂CH₂Ph signal is obscured by the DMSO signal.

Mass spectrum: [M+H]⁺ found: 270.1200 C₁₇H₂₀NO₂ requires 270.14927, [M+H-H₂O]⁺ found 252.0268 C₁₇H₁₈NO requires 252.13873

N-((*R/S*)-2-Hydroxy-2-phenylacetyl)-*L*-leucine methyl ester (27a)

Thionyl chloride (5.84ml, 0.08mol) was cautiously added to methanol (200ml) which was stirring at 0°C. *N*-((*R/S*)-2-Hydroxy-2-phenylacetyl)-*L*-leucine (5.3g, 0.02mol) was then added to the reaction mixture in portions. The reaction was allowed to proceed at room temperature overnight, the excess thionyl chloride and methanol distilled off and the residue dissolved in ethyl acetate. The organic phase was washed with 10% sodium hydrogen carbonate solution, water, 5% hydrochloric acid, water and dried. The solvent was removed *in vacuo* and the resultant oil purified by flash chromatography on silica gel [petroleum ether/ethyl acetate (6:4)] to yield the title compound as a yellow oil (4.8g, 86%).

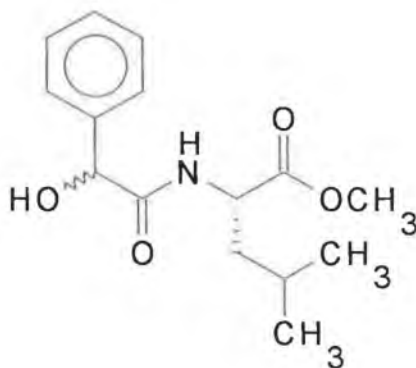

Spectroscopic analysis

i.r. ν_{\max} (CHCl₃): 3422 (OH), 1730 (ester C=O), 1635 (amide C=O), 1280, 1064, 1028cm⁻¹.

¹H-n.m.r.(400MHz) δ (CDCl₃): 0.81 (12H, m, -NHCH(CH₂CH(CH₃)₂)CO₂CH₃), 1.48-1.61 (6H, m, -NHCH(CH₂CH(CH₃)₂)CO₂CH₃ and -NHCH(CH₂CH(CH₃)₂)CO₂CH₃), 3.41 & 3.66 (6H, 2 diastereomeric singlets, -NHCH(CH₂CH(CH₃)₂)CO₂CH₃), 4.49-4.56 (2H, m, -NHCH(CH₂CH(CH₃)₂)CO₂CH₃), 4.94-4.97 (2H, m, PhCH(OH)CO-), 7.13 (2H, d, J=8.36Hz, -NH), 7.22-7.36 (10H, m, ArH).

^{13}C -n.m.r.(100MHz) δ (CDCl_3): 173.27, 172.63, 172.37 (-NHCH(CH₂CH(CH₃)₂)CO₂CH₃ and PhCH(OH)CO-), 139.35, 139.13, 128.38, 128.29, 128.17, 128.03, 126.76, 126.41 (aromatic carbons), 73.83 (PhCH(OH)CO-), 52.16, 52.10, (-NHCH(CH₂CH(CH₃)₂)CO₂CH₃), 50.38, 50.31 (-NHCH(CH₂CH(CH₃)₂)CO₂CH₃), 40.91, 40.85 (-NHCH(CH₂CH(CH₃)₂)CO₂CH₃), 24.60 (-NHCH(CH₂CH(CH₃)₂)CO₂CH₃), 22.56, 21.51 (-NHCH(CH₂CH(CH₃)₂)CO₂CH₃).

N-((R/S)-2-Hydroxy-2-phenylacetyl)-L-phenylalanine methyl ester (27b)

Thionyl chloride (5.84ml, 0.08mol), was cautiously added to methanol (200ml) which was stirring at 0°C. N-((R/S)-2-Hydroxy-2-phenylacetyl)-L-phenylalanine (5.98g, 0.02mol) was then added to the reaction mixture in portions. The reaction was allowed to proceed at room temperature overnight, the excess thionyl chloride and methanol distilled off and the resultant dissolved in ethyl acetate. The organic phase was washed with 10% sodium hydrogen carbonate solution, water, 5% hydrochloric acid, water and dried. The solvent was removed *in vacuo* and recrystallization of the resultant crude product from ethyl acetate/petroleum ether 40-60 furnished the title compound as a white crystalline solid (5.13g, 82%).

m.p. 98-100°C (uncorrected).

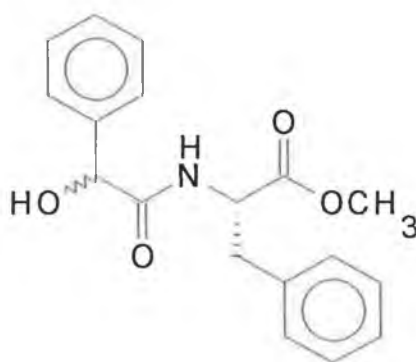

Spectroscopic analysis

i.r. ν_{\max} (KBr): 3474 (OH), 3358 (NH), 1730 (ester C=O), 1657 (amide C=O), 1506, 1452, 1435, 1382, 1289, 1213, 1176, 1119, 1083 cm^{-1} .

$^1\text{H-n.m.r.}$ (400MHz) δ (CDCl_3): 2.95-3.11 (4H, m, $-\text{NHCH}(\text{CH}_2\text{Ph})\text{CO}_2\text{CH}_3$), 3.64 & 3.66 (6H, 2 diastereomeric singlets, $-\text{NHCH}(\text{CH}_2\text{Ph})\text{CO}_2\text{CH}_3$), 4.76-4.81 (2H, m, $-\text{NHCH}(\text{CH}_2\text{Ph})\text{CO}_2\text{CH}_3$), 4.94 (2H, s, $\text{PhCH}(\text{OH})\text{CO}-$), 6.95-6.97 (2H, m, $-\text{NH}$), 7.14-7.30 (20H, m, ArH).

$^{13}\text{C-n.m.r.}$ (100MHz) δ (CDCl_3): 172.23, 172.03, 171.77 ($-\text{NHCH}(\text{CH}_2\text{Ph})\text{CO}_2\text{CH}_3$ and $\text{PhCH}(\text{OH})\text{CO}-$), 139.10, 138.95, 135.46, 135.27, 129.10, 128.97, 128.64, 128.38, 128.17, 126.92, 126.76, 126.49 (aromatic carbons), 73.98, 73.77 ($\text{PhCH}(\text{OH})\text{CO}-$), 52.90, 52.69 ($-\text{NHCH}(\text{CH}_2\text{Ph})\text{CO}_2\text{CH}_3$), 52.31, 52.26 ($\text{NHCH}(\text{CH}_2\text{Ph})\text{CO}_2\text{CH}_3$), 37.58, 37.46 ($-\text{NHCH}(\text{CH}_2\text{Ph})\text{CO}_2\text{CH}_3$).

N-((R/S)-O-Methanesulphonyl-2-hydroxy-2-phenylacetyl)-L-leucine methyl ester (28a)

Methanesulphonyl chloride (2.32ml, 0.03mol) was added to a solution of *N-((R/S)-2-hydroxy-2-phenylacetyl)-L-leucine methyl ester* (2.79g, mol) and triethylamine (3.62ml, 0.026mol) in dichloromethane (150ml) at 0°C. The reaction was stirred at this temperature for 2hr, the dichloromethane evaporated and the residue taken up in ethyl acetate. The organic layer was washed with ice water, cold 1M hydrochloric acid, saturated sodium bicarbonate and dried. The solvent was removed *in vacuo* and precipitation from ethyl acetate/petroleum ether 40-60 yielded the title compound as a white crystalline solid (2.82g, 79%).

m.p. 50-52°C.

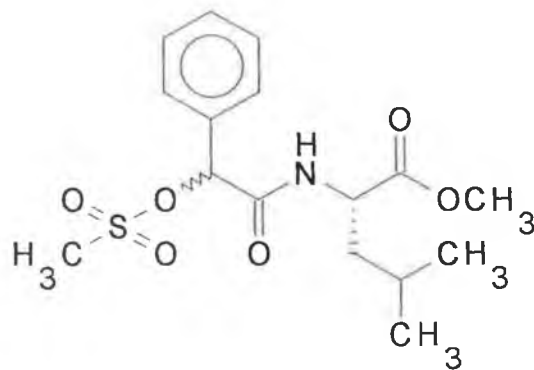

Spectroscopic analysis

i.r ν_{\max} (CHCl₃): 3372 (NH), 1732 (ester C=O), 1523, 1455, 1412, 1208cm⁻¹.

¹H-n.m.r.(400MHz) δ (CDCl₃): 0.89-0.97 (12H, m, -NHCH(CH₂CH(CH₃)₂)CO₂CH₃), 1.59-1.73 (6H, m, -NHCH(CH₂CH(CH₃)₂)CO₂CH₃), and -NHCH(CH₂CH(CH₃)₂)CO₂CH₃), 2.84 & 2.95 (6H, 2 diastereomeric singlets, PhCH(OSO₂CH₃)CO-), 3.73 (6H, 2 diastereomeric singlets, -NHCH(CH₂CH(CH₃)₂)CO₂CH₃), 4.62-4.68 (2H, m, -NHCH(CH₂CH(CH₃)₂)CO₂CH₃), 5.92 (2H, s, PhCH(OSO₂CH₃)CO-), 6.90 (2H, d, J=8.36Hz, -NH), 7.40-7.50 (10H, m, ArH).

¹³C-n.m.r.(100MHz) δ (CDCl₃): 172.68, 172.56 (-NHCH(CH₂Ph)CO₂CH₃), 166.72, 166.67 (PhCH(OSO₂CH₃)CO-), 133.73, 129.96, 129.84, 129.06, 129.03, 128.99, 128.06, 127.67, 127.56 (aromatic carbons), 81.20 PhCH(OSO₃CH₃), 52.39, 52.34 (-NHCH(CH₂CH(CH₃)₂)CO₂CH₃), 50.75, 50.71, (-NHCH(CH₂CH(CH₃)₂)CO₂CH₃), 41.07, 40.98 (-NHCH(CH₂CH(CH₃)₂)CO₂CH₃), 39.31, 39.16, (PhCH(OSO₂CH₃), 24.75 (-NHCH(CH₂CH(CH₃)₂)CO₂CH₃), 22.69, 21.60 (-NHCH(CH₂CH(CH₃)₂)CO₂CH₃).

N-((*R/S*)-*O*-Methanesulphonyl-2-hydroxy-2-phenylacetyl)-*L*-phenylalanine

methyl ester (28b)

Methanesulphonyl chloride (2.32ml, 0.03mol) was added to a solution of *N*-((*R/S*)-2-hydroxy-2-phenylacetyl)-*L*-phenylalanine methyl ester (3.13g, 0.01mol) and triethylamine (3.62ml, 0.026mol) in dichloromethane (150ml) at 0°C. The reaction was stirred at this temperature for 2hr, the dichloromethane evaporated and the residue taken up in ethyl acetate. The organic layer was washed with ice water, cold 1M hydrochloric acid, saturated sodium bicarbonate and dried. The solvent was removed *in vacuo* and precipitation from ethyl acetate/petroleum ether yielded the title compound as a white crystalline solid (2.97g, 76%).

m.p. 114-116°C (uncorrected).

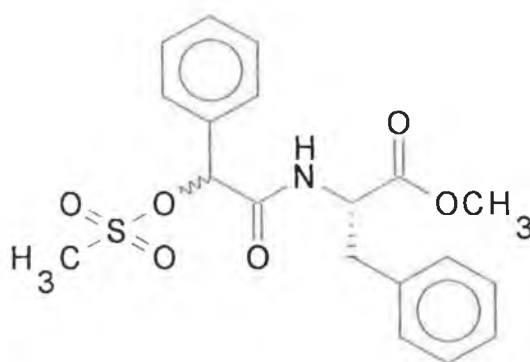

Spectroscopic analysis

i.r ν_{\max} (KBr): 3290 (NH), 1746 (ester C=O), 1665 (amide C=O), 1542, 1496, 1452, 1439, 1355, 1280, 1225, 1196, 1178, 1123cm⁻¹

¹H-n.m.r.(400MHz) δ (CDCl₃): 2.87 (6H, s, PhCH(OSO₂CH₃)CO-), 3.06 (2H, dd, J_A=14.28Hz, J_B=7.4Hz, -NHCH(CH₂Ph)CO₂CH₃), 3.24 (2H, dd, J_A=14.28Hz, J_B=5.44Hz, -NHCH(CH₂Ph)CO₂CH₃), 3.77 (6H, s, -NHCH(CH₂Ph)CO₂CH₃), 4.89-4.95 (2H, m, -NHCH(CH₂Ph)CO₂CH₃), 5.85 (2H, s, PhCH(OSO₂CH₃)CO-), 6.84 (2H, d, J=7.88Hz, -NH), 7.23-7.40 (20H, m, ArH).

^{13}C -n.m.r.(100MHz) δ (CDCl_3): 171.25 (-NHCH(CH₂Ph)CO₂CH₃), 166.45 (PhCH(OSO₂CH₃)CO-), 135.34, 133.54, 129.82, 129.21, 129.01, 128.67, 127.55, 127.23 (aromatic carbons), 81.09 (PhCH(OSO₂CH₃)CO-), 52.98 (-NHCH(CH₂Ph)CO₂CH₃), 52.60 (-NHCH(CH₂Ph)CO₂CH₃), 39.19 (PhCH(OSO₂CH₃)CO-), 37.52 (-NHCH(CH₂Ph)CO₂CH₃).

N-((R/S)-O-Methanesulphonyl-2-hydroxy-2-phenylacetyl) phenethylamide (28c)

Methanesulphonyl chloride (2.32ml, 0.03mol) was added to a solution of N-((R/S)-2-hydroxy-2-phenylacetyl) phenethylamide (2.55g, 0.01mol) and triethylamine (3.62ml, 0.026mol) in dichloromethane (150ml) at 0°C. The reaction was stirred at this temperature for 2hr, the dichloromethane evaporated and the residue taken up in ethyl acetate. The organic layer was washed with ice water, cold 1M hydrochloric acid, saturated sodium bicarbonate and dried. The solvent was removed *in vacuo* and recrystallization of the crude product from ethyl acetate/petroleum ether yielded the title compound as a white crystalline solid.

m.p. 92-94°C (uncorrected).

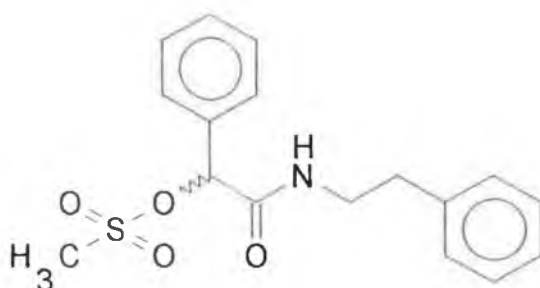

Spectroscopic analysis

i.r. ν_{\max} (KBr): 3343 (NH), 1658 (amide C=O), 1534, 1496, 1456, 1348, 1279, 1199, 1172, 1086, 1075, 1039 cm^{-1} .

^1H -n.m.r.(400MHz) δ (CDCl_3): 2.78 (6H, s, $\text{PhCH}(\text{OSOCH}_3)\text{CO-}$), 2.79-2.86 (4H, m, $-\text{NHCH}_2\text{CH}_2\text{Ph}$), 3.54-3.60 (4H, m, $-\text{NHCH}_2\text{CH}_2\text{Ph}$), 5.83 (2H, s, $\text{PhCH}(\text{OSO}_2\text{CH}_3)\text{CO-}$), 6.53 (2H, s, $-\text{NH}$), 7.14-7.39 (20H, m, ArH).

^{13}C -n.m.r.(100MHz) δ (CDCl_3): 166.66 ($\text{PhCH}(\text{OSO}_2\text{CH}_3)\text{CO-}$), 138.22, 133.89, 129.84, 129.05, 128.73, 127.67, 126.59 (aromatic carbons), 81.40 ($\text{PhCH}(\text{OSO}_2\text{CH}_3)\text{CO-}$), 40.60 ($-\text{NHCH}_2\text{CH}_2\text{Ph}$), 39.18 ($\text{PhCH}(\text{OSO}_2\text{CH}_3)\text{CO-}$), 35.28 ($-\text{NHCH}_2\text{CH}_2\text{Ph}$).

N-((*R/S*)-2-Acethio-2-phenylacetyl)-L-leucine methyl ester (29a)

Potassium thioacetate (2.86g, 0.025mol) was added to a solution of *N*-((*R/S*)-*O*-methanesulphonyl-2-hydroxy-2-phenylacetyl)-L-leucine methyl ester (1.79g, 0.005mol) in dry dimethylformamide (50ml). The reaction mixture was stirred at room temperature for 5 days under a positive N_2 pressure. The reaction mixture was extracted with ethyl acetate, washed with brine, dried and the solvent evaporated. The residue was taken up in dichloromethane and treated with activated charcoal to remove much of the brown colour. Purification by flash chromatography on silica gel [chloroform] furnished the title compound as a yellow waxy solid (0.92g, 55%).

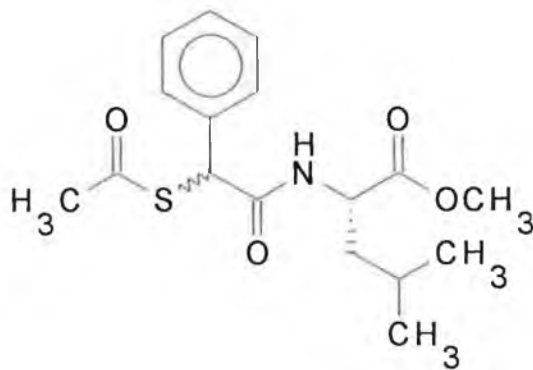

Spectroscopic analysis

i.r. ν_{\max} (CHCl₃): 3324 (NH), 1744 (ester C=O), 1694 (amide C=O), 1536, 1496, 1469, 1453, 1437, 1354, 1275, 1205, 1135cm⁻¹.

¹H-n.m.r.(400MHz) δ (CDCl₃): 0.83-0.91 (12H, m, -NHCH(CH₂CH(CH₃)₂)CO₂CH₃), 1.45-1.65 (6H, m, -NHCH(CH₂CH(CH₃)₂)CO₂CH₃ and -NHCH(CH₂CH(CH₃)₂)CO₂CH₃), 2.36 (6H, s, PhCH(SCOCH₃)CO-), 3.66 & 3.70 (6H, 2 diastereomeric singlets, -NHCH(CH₂CH(CH₃)₂)CO₂CH₃), 4.54-4.61 (2H, m, -NHCH(CH₂CH(CH₃)₂)CO₂CH₃), 5.25 & 5.26 (2H, 2 diastereomeric singlets, PhCH(SCOCH₃)CO-), 6.55 (2H, m, -NH), 7.26-7.40 (10H, m, ArH).

¹³C-n.m.r.(100MHz) δ (CDCl₃): 194.53 (PhCH(SCOCH₃)CO-), 172.91, 172.84 (-NHCH(CH₂CH(CH₃)₂)CO₂CH₃), 168.68 (PhCH(SCOCH₃)CO-), 135.29, 122.76, 128.53, 128.49, 128.28, 128.24 (aromatic carbons), 52.22, 52.17 (-NHCH(CH₂CH(CH₃)₂)CO₂CH₃), 51.63, (-PhCH(SCOCH₃)CO-), 51.15, 51.11 (-NHCH(CH₂CH(CH₃)₂)CO₂CH₃), 41.33, 41.16 (-NHCH(CH₂CH(CH₃)₂)CO₂CH₃), 30.00 (PhCH(SCOCH₃)CO-), 24.70 (-NHCH(CH₂CH(CH₃)₂)CO₂CH₃), 22.70, 21.72 (-NHCH(CH₂CH(CH₃)₂)CO₂CH₃).

Mass spectrum: [M+H]⁺ found: 338.0021 C₁₇H₂₄NO₄S requires 338.14242, [M+H-CH₂CO]⁺ found 296.0193 C₁₅H₂₂NO₃S requires 296.13188

N-((*R/S*)-2-Acethio-2-phenylacetyl)-*L*-phenylalanine methyl ester (29b)

Potassium thioacetate (2.86g, 0.025mol) was added to a solution of *N*-((*R/S*)-*O*-methanesulphonyl-2-hydroxy-2-phenylacetyl)-*L*-phenylalanine methyl ester (1.95g, 0.005mol) in dry dimethylformamide (50ml). The reaction mixture was stirred at room temperature for 5 days under a positive N₂ pressure. The reaction mixture was extracted with ethyl acetate, washed with brine, dried and the solvent evaporated. The residue was taken up in dichloromethane and treated with activated charcoal to remove much of the brown colour. Purification by flash chromatography on silica gel [chloroform] gave the title compound as a white solid (1.05g, 57%).

m.p. 98-100°C (uncorrected).

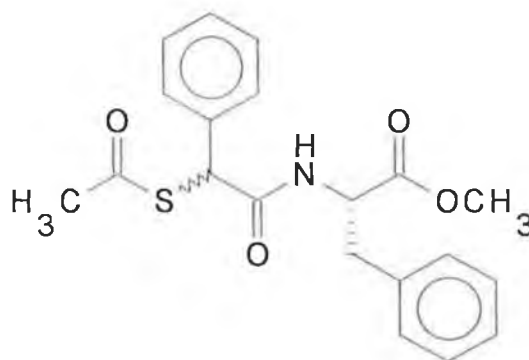

Spectroscopic analysis

i.r. ν_{\max} (KBr): 3309 (NH), 1740 (ester C=O), 1655 (amide C=O), 1530, 1495, 1452, 1432, 1351, 1315, 1278, 1230, 1174, 1132, 1102cm⁻¹.

¹H-n.m.r.(400MHz) δ (CDCl₃): 2.33 & 2.34 (6H, 2 diastereomeric singlets, PhCH(SCOCH₃)CO-), 3.00-3.20 (4H, m, -NHCH(CH₂Ph)CO₂CH₃), 3.70 & 3.73 (6H, 2 diastereomeric singlets, -NHCH(CH₂Ph)CO₂CH₃), 4.81-4.88 (2H, m, -NHCH(CH₂Ph)CO₂CH₃), 5.18 (2H, 2 diastereomeric singlets, PhCH(SOCH₃)CO-), 6.41 & 6.49 (2H, 2 distereomeric doublets, J=7.64Hz, -NH), 6.81-7.34 (20H, m, ArH).

^{13}C -n.m.r.(100MHz) δ (CDCl_3): 194.54 ($\text{PhCH}(\text{SCOCH}_3)\text{CO-}$), 172.87, 172.80, ($-\text{NHCH}(\text{CH}_2\text{Ph})\text{CO}_2\text{CH}_3$), 168.71 ($\text{PhCH}(\text{SCOCH}_3)\text{CO-}$), 135.65, 135.33, 129.28, 129.20, 128.96, 128.85, 128.60, 128.56, 128.53, 128.47, 128.41, 128.38, 127.03 (aromatic carbons), 53.54, 53.45 ($-\text{NHCH}(\text{CH}_2\text{Ph})\text{CO}_2\text{CH}_3$), 52.42, 52.37 ($\text{PhCH}(\text{SCOCH}_3)\text{CO-}$), 51.58 ($-\text{NHCH}(\text{CH}_2\text{Ph})\text{CO}_2\text{CH}_3$), 37.60, 37.46 ($-\text{NHCH}(\text{CH}_2\text{Ph})\text{CO}_2\text{CH}_3$), 30.08 ($\text{PhCH}(\text{SCOCH}_3)\text{CO-}$).

Mass spectrum: $[\text{M}+\text{H}]^+$ found: 372.0507 $\text{C}_{20}\text{H}_{22}\text{NO}_4\text{S}$ requires 372.12678, $[\text{M}+\text{Na}]^+$, found 394.10187 $\text{C}_{20}\text{H}_{21}\text{NO}_4\text{SNa}$ requires 394.10896, $[\text{M}+\text{H}-\text{CH}_2\text{CO}]^+$ found 329.9734 $\text{C}_{18}\text{H}_{20}\text{NO}_3\text{S}$ requires 330.11624

***N*-((*R/S*)-2-Acethio-2-phenylacetyl) phenethylamide (29c)**

Potassium acetate (2.86g, 0.025mol) was added to a solution of *N*-((*R/S*)-*O*-methanesulphonyl-2-hydroxy-2-phenylacetyl) phenethylamide (1.76g, 0.005mol) in dry dimethylformamide (50ml). The reaction mixture was stirred at room temperature for 5 days under a positive N_2 pressure. The reaction mixture was extracted with ethyl acetate, washed with brine, dried and the solvent evaporated. The residue was taken up in dichloromethane and treated with activated charcoal to remove much of the brown colour. Purification by flash chromatography on silica gel [chloroform] yielded the title compound as a white solid (0.84g, 54%).

m.p. 82-84°C.

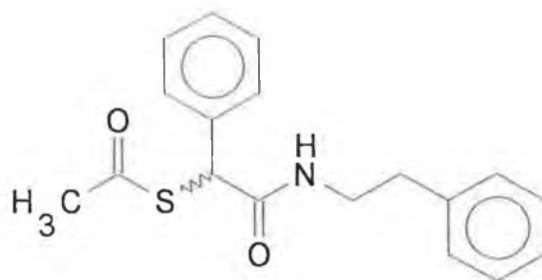

Spectroscopic analysis

i.r. ν_{\max} (KBr): 3346 (NH), 1690, 1658 (amide C=O), 1530, 1497, 1454, 1356, 1313, 1288, 1221, 1198, 1138, 1108, 1075, 1029 cm^{-1} .

^1H -n.m.r.(400MHz) δ (CDCl_3): 2.32 (6H, s, $\text{PhCH}(\text{SCOCH}_3)\text{CO-}$), 2.74-2.80 (4H, m, $-\text{NHCH}_2\text{CH}_2\text{Ph}$), 3.42-3.56 (4H, m, $-\text{NHCH}_2\text{CH}_2\text{Ph}$), 5.13 (2H, s, $\text{PhCH}(\text{SCOCH}_3)\text{CO-}$), 6.02 (2H, s, $-\text{NH}$), 7.06-7.35 (20H, m, ArH).

^{13}C -n.m.r.(100MHz) δ (CDCl_3): 194.53 ($\text{PhCH}(\text{SCOCH}_3)\text{CO-}$), 168.81 ($\text{PhCH}(\text{SCOCH}_3)\text{CO-}$), 138.52, 135.84, 128.84, 128.73, 128.53, 128.50, 128.26, 126.42 (aromatic carbons), 52.07 ($\text{PhCH}(\text{SCOCH}_3)\text{CO-}$), 41.15 ($-\text{NHCH}_2\text{CH}_2\text{Ph}$), 35.29 ($-\text{NHCH}_2\text{CH}_2\text{Ph}$), 30.08 ($\text{PhCH}(\text{SCOCH}_3)\text{CO-}$).

Attempted preparation of *N*-((*R/S*)-2-thio-2-phenylacetyl)-L-leucine

1M NaOH (10ml) was added to a stirred solution of *N*-((*R/S*)-2-acethio-2-phenylacetyl)-L-phenylalanine methyl ester (1.74g, 0.005mol) in methanol (12ml). After 1hr the reaction was cooled on an ice bath and acidified with dilute hydrochloric acid. The methanol was evaporated and the solution allowed to cool. The resultant precipitate was filtered and dried. Attempted purification of the precipitate by recrystallization from ethanol/water did not yield the desired product and the reaction was not investigated further.

Attempted preparation of *N*-((*R/S*)-2-thio-2-phenylacetyl)-L-phenylalanine

1M NaOH (10ml) was added to a stirred solution of *N*-((*R/S*)-2-acethio-2-phenylacetyl)-L-phenylalanine methyl ester (1.91g, 0.005mol) in methanol (12ml). After 1hr the reaction was cooled on an ice bath and acidified with dilute hydrochloric acid. The methanol was evaporated and the solution allowed to cool. The resultant precipitate was filtered and

dried. Attempted purification of the precipitate by recrystallization from ethanol/water did not yield the desired product and the reaction was not investigated further.

N-((*R/S*)-2-Thio-2-phenylacetyl) phenethylamide (30)

1M NaOH (10ml) was added to a stirred solution of *N*-((*R/S*)-2-acethio-2-phenylacetyl) phenethylamide (1.56g, 0.005mol) in methanol (12ml). After 1hr the reaction was cooled on an ice bath and acidified with dilute hydrochloric acid. The methanol was removed *in vacuo*, and the solution allowed to cool. The resultant precipitate was filtered and dried. Recrystallization from acetone/*n*-hexane yielded the title compound as a white crystalline solid (0.69g, 51%).

m.p. 202-204°C.

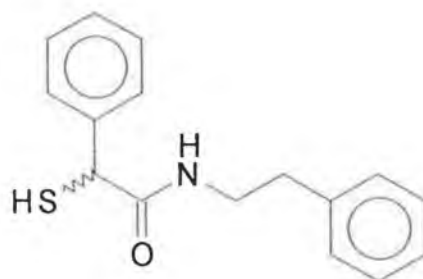

Spectroscopic analysis

i.r. ν_{\max} (KBr): 3293 (NH), 1652 (amide C=O), 1534, 1495, 1452, 1313, 1227, 1197 cm^{-1} .

^1H -n.m.r.(400MHz) δ (DMSO): 2.64-2.68 (4H, m, -NHCH₂CH₂Ph), 3.25-3.30 (4H, m, -NHCH₂CH₂Ph), 4.74 (2H, s, PhCH(SH)CO-), 7.08-7.40 (20H, m, ArH), 8.39 (2H, t, J=5.66Hz, -NH).

^{13}C -n.m.r.(100MHz) δ (DMSO): 168.57 (PhCH(SH)CO-), 139.18, 136.80, 128.64, 128.52, 128.40, 128.25, 128.02, 126.03 (aromatic carbons), 58.44 (PhCH(SH)CO-), 40.73 (-NHCH₂CH₂Ph), 34.90 (-NHCH₂CH₂Ph).

Mass spectrum: $[\text{M}+\text{H}]^+$ found: 272.1298 $\text{C}_{16}\text{H}_{18}\text{NOS}$ requires 272.1108

N-BOC-D-leucine methyl ester (31a)

Di-*tert*-butyldicarbonate (2.18g, 0.01mol) in dichloromethane (20ml) was added slowly to a solution of L-leucine methyl ester (1.82g, 0.01mol) and triethylamine (1.4ml, 0.01mol) in dichloromethane (50ml) at 0°C. After 30min the temperature was raised to room temperature and the reaction continued for 4hr. The reaction mixture was washed with cold 2.5% hydrochloric acid (2x10ml), 10% sodium hydrogen carbonate (2x25ml), water and dried. Purification of the product by passing through a pad of silica gel [diethyl ether] yielded the title product as a clear oil (2.26g, 92%).

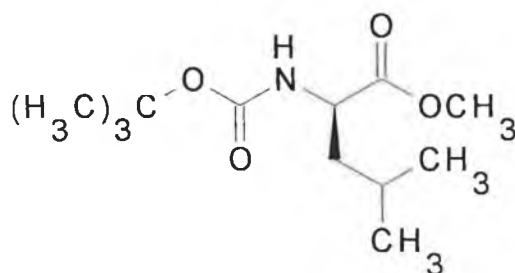

Spectroscopic analysis

i.r. ν_{\max} (CHCl₃): 3376 (NH), 1760 (ester C=O), 1501, 1368cm⁻¹.

¹H-n.m.r.(400MHz) δ (CDCl₃): 0.94 (6H, m, -NHCH(CH₂CH(CH₃)₂)CO₂CH₃), 1.45 (9H, s, ((H₃C)₃COCO-), 1.56-1.74 (3H, m, -NHCH(CH₂CH(CH₃)₂)CO₂CH₃ and -NHCHCH(CH₂CH(CH₃)₂)CO₂CH₃), 3.73 (3H, s, -NHCH₂CH(CH₃)₂CO₂CH₃), 4.32 (1H, m, -NHCH(CH₂CH(CH₃)₂)CO₂CH₃), 5.11 (1H, d, J=7.4Hz, NH).

¹³C-n.m.r.(100MHz) δ (CDCl₃): 173.84 (-NHCH(CH₂CH(CH₃)₂)CO₂CH₃), 155.28 ((H₃C)₃COCO-), 79.48 ((H₃C)₃COCO-), 51.82 (-NHCH(CH₂CH(CH₃)₂)CO₂CH₃), 45.98 (-NHCH(CH₂CH(CH₃)₂)CO₂CH₃), 41.50 (-NHCH(CH₂CH(CH₃)₂)CO₂CH₃), 28.09, ((H₃C)₃COCO-), 24.54 (-NHCH(CH₂CH(CH₃)₂)CO₂CH₃), 22.62, 21.64 (-NHCH(CH₂CH(CH₃)₂)CO₂CH₃).

N-BOC-D-phenylalanine methyl ester (31b)

Di-*tert*-butyldicarbonate (2.18g, 0.01mol) in dichloromethane (20ml) was added slowly to a solution of L-phenylalanine methyl ester hydrochloride (2.16g, 0.01mol) and triethylamine (1.4ml, 0.01mol) in dichloromethane (50ml) at 0°C. After 30min the temperature was raised to room temperature and the reaction continued for 4hr. The reaction mixture was washed with cold 2.5% hydrochloric acid (2x10ml), 10% sodium hydrogen carbonate (2x25ml), water and dried. Purification of the product by passing through a pad of silica gel [diethyl ether] yielded the title product as a waxy solid (2.63g, 94%).

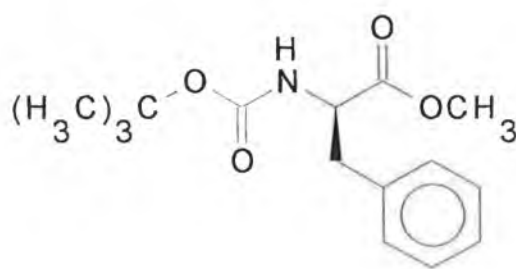

Spectroscopic analysis

i.r. ν_{\max} (CHCl₃): 3370 (NH), 1740 (ester C=O), 1682, 1605, 1504, 1169, 1055cm⁻¹.

¹H-n.m.r.(400MHz) δ (CDCl₃): 1.41 (9H, s, ((H₃C)₃COCO-), 3.00-3.13 (2H, m, -NHCH(CH₂Ph)CO₂CH₃), 3.68 (3H, s, -NHCH(CH₂Ph)CO₂CH₃), 4.58 (1H, m -NHCH(CH₂Ph)CO₂CH₃), 5.10 (1H, d, J=7.88Hz, -NHCH(CH₂Ph)CO₂CH₃), 7.08-7.30 (5H, m, ArH).

¹³C-n.m.r.(400MHz) δ (CDCl₃): 172.18 (-NHCH(CH₂Ph)CO₂CH₃), 154.91 ((H₃C)₃COCO-), 135.88, 129.13, 128.25, 126.78 (aromatic carbons), 79.61 ((H₃C)₃COCO-) 51.97 (-NHCH(CH₂Ph)CO₂CH₃), 46.02 (-NHCH(CH₂Ph)CO₂CH₃), 38.09 (-NHCH(CH₂Ph)CO₂CH₃), 28.09 ((H₃C)₃COCO-).

N-BOC-D-leucinal (32a)

A solution of 1M diisobutylaluminium hydride in hexane (25ml, 0.025mol) was added dropwise to a solution of *N*-BOC-L-leucine methyl ester (2.45g, 0.01mol) in dry toluene (100ml) at -70°C under an atmosphere of N₂. After 20min the reaction was quenched by the addition of methanol (4ml) and Rochelle salt solution was added. After the reaction was allowed to warm to room temperature the mixture was extracted with ether (3x50ml). The ether layers were dried and concentrated under vacuum. The crude product was passed through a short pad of silica gel [petroleum ether 40-60/ethyl acetate (9:1)] to yield the title product¹¹² as a colourless oil (1.03g, 48%).

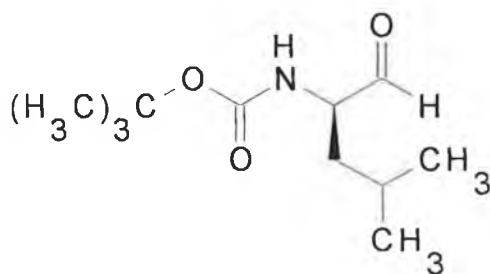

Spectroscopic analysis

i.r. ν_{\max} (CHCl₃): 3344 (NH), 1697 (C=O), 1513, 1367, 1252, 1169cm⁻¹.

¹H-n.m.r.(400MHz) δ (CDCl₃): 0.96 (6H, d, J=6.4Hz, -NHCH(CH₂CH(CH₃)₂)CHO), 1.45 (9H, s, ((H₃C)₃COCO-), 1.60-1.83 (3H, m, -NHCH(CH₂CH(CH₃)₂)CHO and -NHCH(CH₂CH(CH₃)₂)CHO), 4.24 (1H, m, -NHCH(CH₂CH(CH₃)₂)CHO), 5.09 (1H, m, -NH), 9.59 (1H, s, -NHCH(CH₂CH(CH₃)₂)CHO).

¹³C-n.m.r.(100MHz) δ (CDCl₃): 200.46 (-NHCH(CH₂CH(CH₃)₂)CHO), 155.12 ((H₃C)₃COCO-) 79.91 ((H₃C)₃COCO-) 58.29 (-NHCH(CH₂CH(CH₃)₂)CHO), 37.92 (-NHCH(CH₂CH(CH₃)₂)CHO), 28.17 ((H₃C)₃COCO-), 22.99 (-NHCH(CH₂CH(CH₃)₂)CHO), 22.38, 21.80 (-NHCH(CH₂CH(CH₃)₂)CHO).

N-BOC-*D*-phenylalaninal (32b)

A solution of 1M diisobutylaluminium hydride in hexane (25ml, 0.025mol) was added dropwise to a solution of *N*-BOC-*L*-phenylalanine methyl ester (2.79g, 0.01mol) in dry toluene (100ml) at -70°C under an atmosphere of N_2 . After 20min the reaction was quenched by the addition of methanol (4ml) and Rochelle salt solution was added. After the reaction was allowed to warm to room temperature the mixture was extracted with ether (3x50ml). The ether layers were dried and concentrated under vacuum. The crude product was passed through a short pad of silica gel [petroleum ether/ethyl acetate (9:1)] to yield the title product¹⁵⁸ as a white solid. (1.32g, 53%).

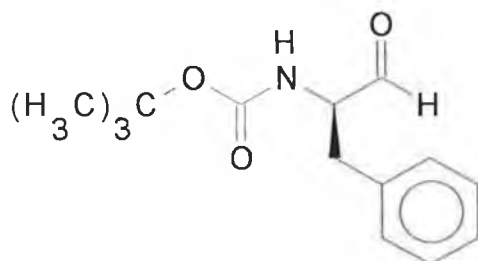

i.r. ν_{max} (KBr): 3423 (NH), 1688 (C=O), 1519, 1369, 1168, 1074 cm^{-1} .

^1H -n.m.r.(400MHz) δ (CDCl_3): 1.43 (9H, s, ((H_3C) $_3$ COCO-), 3.11 (2H, d, $J=6.88\text{Hz}$, -NHCH(CH_2Ph)CHO), 4.42 (1H, m, -NHCH(CH_2Ph)CHO), 5.07 (1H, d, $J=5.4\text{Hz}$, -NH), 7.16-7.33 (5H, m, ArH), 9.63 (1H, s, -NHCH(CH_2Ph)CHO).

^{13}C -n.m.r.(100MHz) δ (CDCl_3): 199.39 (-NHCH(CH_2Ph)CHO), 154.96 ((H_3C) $_3$ COCO-), 135.74, 129.29, 128.41, 127.02 (aromatic carbons), 60.72, (-NHCH(CH_2Ph)CHO), 35.40 (-NHCH(CH_2Ph)CHO), 28.29 ((H_3C) $_3$ COCO-).

Note: The (H_3C) $_3$ COCO- signal is obscured by the CDCl_3 signal.

Attempted preparation of (3(S/R)-4R)-N-BOC-4-amino-3-hydroxy-6-methylheptene

A 1M solution of vinylmagnesium bromide in THF (20ml, 0.02mol) was added dropwise to a solution of freshly prepared BOC-D-leucinal (2.15g, 0.01mol) in THF (25ml) which was stirring at -78°C under an atmosphere of N₂. After the additon was complete the reaction mixture was allowed to warm to room temperature and poured into a saturated solution of ammonium chloride. The resulting slurry was extracted with ether (3x50ml) and the combined ether extracts dried and the solvent evaporated. Attempted purification by flash chromatography on silica gel [toluene / ethyl acetate (8:2)] did not yield the desired product and the reaction was not investigated further.

Attempted preparation of (3(S/R)-4R)-N-BOC-4-amino-3-hydroxy-5-Phenylpentene

A 1M solution of vinylmagnesium bromide in THF (20ml, 0.02mol) was added dropwise to a solution of freshly prepared BOC-D-phenylalaninal (2.49g, 0.01mol) in THF (25ml) which was stirring at -78°C under an atmosphere of N₂. After the additon was complete the reaction mixture was allowed to warm to room temperature and poured into a saturated solution of ammonium chloride. The resulting slurry was extracted with ether (3x50ml) and the combined ether extracts dried and the solvent evaporated. Attempted purification by flash chromatography on silica gel [toluene / ethyl acetate (8:2)] did not yield the desired product and the reaction was not investigated further.

CHAPTER FIVE
BIOLOGICAL RESULTS

Introduction

A standard assay has been developed using a synthetic fluorogenic substrate to test the activity of the compounds that were prepared during the course of this study. Many assays for metalloprotease substrates have been based on synthetic oligopeptides in which the scissile bond is an amide bond with a fluorogenic species.^{162,163} In this assay activity was determined by measuring the release of 7-amino-4-methyl-coumarin (a fluorescent species), from the substrate L-leucine-7-amido-4-methyl-coumarin (L-leu-AMC) (fig. 5.1) which does not fluoresce upon enzymatic hydrolysis by the aminopeptidase isolated from the rodent malarial parasite *P. chabaudi*. This aminopeptidase is identical to that found in the human malarial parasite *P. falciparum* and thus results obtained in this study can be extrapolated directly to the human malaria parasite. The use of rodent malarial parasites rather than human malarial parasites also greatly facilitates research. The malarial aminopeptidase shows a high degree of activity for L-leu-AMC.²⁰ Cleavage of the amide bond by the enzyme results in the release of free AMC (fig. 5.2). In the presence of a compound which competes for binding sites on the enzyme there is a reduction in the amount of L-leu-AMC cleaved, less free AMC is released and thus less fluorescence is observed.

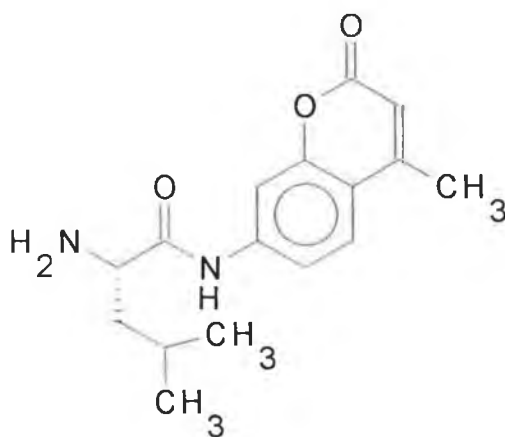

Fig. 5.1 L-leucine-7-amido-4-methyl-coumarin.

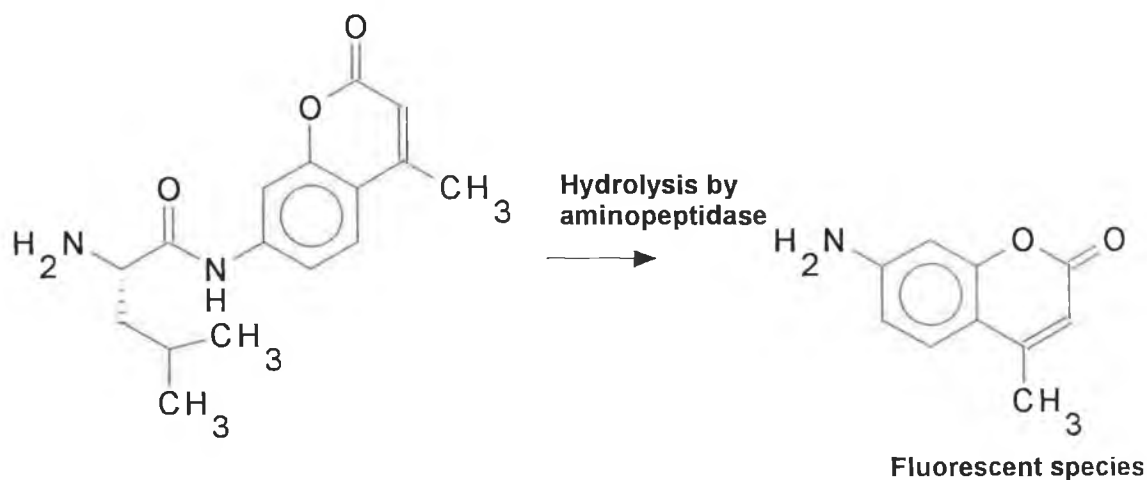

Fig. 5.2 Hydrolysis of L-leu-AMC by aminopeptidase with liberation of fluorescent 7-amino-4-methylcoumarin.

In this assay a crude extract of the *plasmodium* aminopeptidase was added to solutions which had a concentration of $10\mu\text{M}$ of the compounds to be tested and a concentration of $10\mu\text{M}$ of L-leu-AMC in a final volume of 1ml of phosphate buffered saline (PBS) at pH 7.2. The resulting solutions were incubated at 37°C for 30 minutes. The enzyme activity was then quenched by the addition of $200\mu\text{L}$ of 10% acetic acid solution. The amount of liberated AMC was determined using a fluorimeter (excitation 370nm, emission 440nm). The results tabulated below are expressed as fluorescent intensity at a concentration of $10\mu\text{M}$ (IF @ $10\mu\text{M}$), as the percentage inhibition of enzyme activity at this concentration, and as the concentration of inhibitor required to cause a decrease in enzyme activity of 50% (IC_{50}) relative to a positive control (IF @ $10\mu\text{M}=195$) which contained only the parasite extract and the L-leu-AMC. All assays were performed in duplicate and the mean result taken. Results for bestatin at a concentration of $1\mu\text{M}$ were also recorded (IF = 0).

Note: Some of the compounds tested were activators rather than inhibitors of enzyme activity and these are labelled with an asterisk (*) in the tables. For these compounds the

results are expressed as the percentage activation of enzyme activity. The IC₅₀ value was not applicable to these compounds and thus was not calculated.

5.1 *N-trans*-Cinnamoyl and related derivatives

Table 5.1 Results of biological assay for *N-trans*-cinnamoyl and related derivatives.

Compound	IF @ 10μM	% Inhibition / Activation @ 10μM	IC ₅₀ (μM)
1a	123	36.9	13.5
1b	117	40	12.5
1c	70.2	64	7.8
1d	120	38.5	13
1e	104	46.7	10.7
1f	119	40	12.5
1g	66.3	66	7.6
1h	60.5	69	7.2
1i	50.7	74	6.8
1j	56.6	71	7
2	105	46.2	10.8
3a	67	65.6	7.6
3b	52.7	73	6.8
3c	47.2	75.8	6.6
5	93.6	52	9.6
6a*	292	49.7	N/A
6b	55	71.8	7

* Activator

The results of the biological assay for the *N-trans*-cinnamoyl derivatives show that these compounds generally behave as moderate inhibitors with the highest inhibition being observed for *N-trans*-3-nitrocinnamoyl-glycine ethyl ester (**3c**) ($IC_{50}=6.6\mu M$). Their activity is probably due to their structural similarity to bestatin which allows them to “fit in” to the active site. It is assumed that the amide carbonyl could form a monodentate ligand with the active site metal by analogy with the model proposed for bestatin. The electrophilic active site metal may be capable of interacting positively with the electron density around the $C=C$ - bond. The phenyl and carboxylic acid groups may also be able to interact favourably with the active site as described for bestatin.

The level of inhibition recorded for the *N-trans*-3-nitrocinnamoyl glycine derivatives (**3a-c**) ($IC_{50}=7.7-6.6\mu M$) is significantly higher than their *N-trans*-cinnamoyl glycine derivative counterparts (**1a-c**) ($IC_{50}=13.5-7.8\mu M$). It is known that bestatin analogues with an electron-withdrawing group in the *para* position have higher activities than bestatin and that *p*-nitrobestatin has at least five times the activity of bestatin. Although in our case the nitro group is in the *meta* position it still seems to exert an effect by increasing inhibition.

Little difference is observed between the *N-trans*-cinnamoyl derivatives of the different amino acids (**1a, 1d-1f**) with only the L-valine (**1e**) derivative showing a slight improvement in inhibition ($IC_{50}=10.7\mu M$). This is unexpected since the aminopeptidase has a preference for alkyl side chains such as those found in alanine and leucine. This may indicate that the *N-trans*-cinnamoyl derivatives are not binding to the active site in a manner analogous to bestatin in which the leucine, alanine and isoleucine side chains show the greatest activity. The dipeptide *N-trans*-cinnamoyl glycylglycine (**2**) has similar activity to *N-trans*-cinnamoyl glycine. This would suggest that the enzyme does not have an extended binding site but has an affinity for dipeptide-sized molecular chains.

Modifications of the *C*-terminus have a pronounced effect on the activity of the *N-trans*-cinnamoyl derivatives. In general it is observed that the ester derivatives have a greater activity than the corresponding carboxylic acid derivatives. It is plausible that the ester groups facilitate binding to a hydrophobic subsite in the active site. The amide (**1i**) and alcohol (**1j**) also show increased activity over the corresponding free carboxylic acid derivative (**1f**). These results are contradictory to results for bestatin in which a free

carboxylic acid is necessary for full activity. This again may indicate a different mode of binding for the *N-trans*-cinnamoyl derivatives.

An interesting anomaly is observed for the *N*-2,3-dibromopropionyl derivatives (**6a**, **6b**) in which the L-leucine derivative (**6b**) acts as an inhibitor ($IC_{50}=7\mu M$) but the glycine derivative (**6a**) acts as an activator of enzyme activity (% activity @ $10\mu M=49.7$). Little is known about the phenomenon of enzyme activation but it has been observed in some bestatin analogues.¹⁶⁴ Perhaps these compounds have the ability to bind to allosteric sites on the enzyme thus causing a conformational change in the active site which enhances enzyme activity. This is plausible since aminopeptidases tend to be large proteases, for example leucine aminopeptidase has a molecular weight of $\sim 250,000$.⁵⁰ Most proteases are small monomeric enzymes of molecular weight 15,000 to 35,000. It may be that the smaller glycine derivative can bind to another site on the enzyme and that in binding to this site it enhances enzyme activity. The L-leucine derivative may be too large to fit into this proposed site, but still is able to fit into the active site and thus act as an inhibitor.

N-trans-4-Phenylbut-2-enoyl-L-leucine methyl ester (**5**) which has a greater structural similarity to bestatin than *N-trans*-cinnamoyl-L-leucine methyl ester (**1g**) has unexpectedly a lesser activity. It is possible that the rigid -C=C- bond of the *N-trans*-cinnamoyl derivative holds the phenyl group in a fixed position to interact with a hydrophobic subsite in the active site. In the *N-trans*-4-phenylbut-2-enoyl derivative there is free rotation around the benzylic methylene and the phenyl group is not so rigidly held in position.

5.2 N-3,5-Dinitrobenzoyl derivatives

Table 5.2 Results of biological assay for *N*-3,5-dinitrobenzoyl derivatives.

Compound	IF @ 10 μ M	% Inhibition / Activation @ 10 μ M	IC ₅₀
7a	70	64.1	7.8
7b	109	44.1	11.3
7c	72	63.1	7.9
7d	111.5	42.8	11.7
8	144	26.2	19.1

The results of the biological assay again show the *N*-3,5-dinitrobenzoyl derivatives to be acting as moderate inhibitors of the malarial aminopeptidase. The highest inhibition is observed for *N*-3,5-dinitrobenzoyl glycine (**7a**) (IC₅₀=7.8 μ M) and *N*-3,5-dinitrobenzoyl-L-leucine (**7c**) (IC₅₀=7.9 μ M). *N*-3,5-dinitrobenzoyl-L-alanine (**7b**) and *N*-3,5-dinitrobenzoyl-D-leucine (**7d**) had lesser activity. It is interesting to note that although the enzyme is specific for L-amino acids, the D-leucine derivative (**7d**) had a similar activity to the L-alanine derivative. The poorest activity was observed for the dipeptide derivative (**8**) and this again would point to the fact that the enzyme does not have an extended binding site but prefers to bind to dipeptide-sized molecular chains.

5.3 *N*-Toluene-*p*-sulphonyl derivatives

Table 5.3 Results of biological assay for *N*-toluene-*p*-sulphonyl derivatives.

Compound	IF @ 10 μ M	% Inhibition / Activation @ 10 μ M	IC ₅₀ (μ M)
9a	74	62	8.1
9b	76	61	8.2
9c	94	51.8	9.7
9d	78	60	8.3
9e	72	63.1	7.9
9f	79	59.5	8.4
9g	142	27.2	18.4
9h	107	45.1	11.1

The results of the biological assay for the *N*-toluene-*p*-sulphonyl derivatives again show that these compounds behave as moderate inhibitors of the malarial aminopeptidase. Interestingly *N*-toluene-*p*-sulphonyl-L-isoleucine methyl ester (**9f**) (IC₅₀=8.4 μ M) and *N*-toluene-*p*-sulphonyl-L-isoleucine ethyl ester (**9g**) (IC₅₀=18.4 μ M) show less activity than *N*-toluene-*p*-sulphonyl-L-isoleucine (**9e**) (IC₅₀=7.9 μ M). This is a reversal of the trend observed for the previous two sets of compounds in which the esters appear to act as better inhibitors than the free carboxylic acid compounds. The differences observed may be due to a different mode of binding to the enzyme, since unlike the previous two sets of compounds which have an amide linkage, compounds (**9a-h**) contain a sulphonamide bond.

5.4 N-3-Nitrophthaloyl derivatives

Table 5.4 Results of biological assay for *N-3-nitrophthaloyl derivatives*.

Compound	IF @ 10 μ M	% Inhibition / Activation @ 10 μ M	IC ₅₀ (μ M)
10a	104	46.7	10.7
10b	82	57.9	8.6
10c*	454	132.8	N/A
10d*	441	126.2	N/A
10e	78	60	8.3
10f*	341	74.9	N/A
10g*	355	82.1	N/A

* Activator

The *N-3-nitrophthaloyl derivatives* exhibit very different results than the previously described compounds as one would expect from their very different structure. The free carboxylic acid derivatives (**10a**), (**10b**) and (**10e**) behave as weak inhibitors with the best inhibition is seen for the derivatives of L-leucine (**10b**) (IC₅₀=8.6 μ M) and L-isoleucine (**10e**) (IC₅₀=8.3 μ M).

The esters of these compounds (**10c**, **10d**, **10f**, **10g**) actually increase enzyme activity by 132.8%, 126.2%, 74.9% and 82.1% respectively at a concentration of 10 μ M. These results are intriguing and these compounds may merit further study since there may be situations in which the enhancement of aminopeptidase activity may be useful as a chemotherapeutic tool.

5.5 N-Phenylureido derivatives

Table 5.5 Results of biological assay for *N*-phenylureido derivatives.

Compound	IF @ 10 μ M	% Inhibition / Activation @ 10 μ M	IC ₅₀ (μ M)
11a	80	59	8.5
11b	82	57.9	8.6
11c	123	36.9	13.6

The biological results of the *N*-phenylureido derivatives show them to be weak inhibitors of the malarial aminopeptidase. The presence of a urea linkage does not seem to make a significant difference to the activity. The greatest activity is observed for *N*-phenylureido-L-alanine (11a) (IC₅₀=8.5 μ M) and *N*-phenylureido-L-leucine (11b) (IC₅₀=8.6 μ M).

5.6 N-Chloroacetyl derivatives

Table 5.6 Results of biological assay for *N*-Chloroacetyl derivatives.

Compound	IF @ 10 μ M	% Inhibition / Activation @ 10 μ M	IC ₅₀
12a	140	28.2	17.7
12b	129	33.8	14.8
12c	115	41	12.2
12d	99.5	49	10.2
12e	154	21	23.8
13	103	47.2	10.6

The *N*-chloroacetyl derivatives are weak inhibitors of the malarial aminopeptidase. The highest activity was observed for *N*-chloroacetyl-L-leucine ethyl ester (**12d**) ($IC_{50}=10.2\mu M$). The esters *N*-chloroacetyl-L-leucine methyl ester (**12c**) ($IC_{50}=12.2\mu M$) and *N*-chloroacetyl-L-leucine ethyl ester (**12d**) ($IC_{50}=10.2\mu M$) show higher activity than the corresponding free carboxylic acid derivative *N*-chloroacetyl-L-leucine (**12b**) ($IC_{50}=14.8\mu M$). The lowest activity is observed for *N*-chloroacetyl-D-leucine (**12e**) ($IC_{50}=23.8\mu M$) which is consistent with the fact that the enzyme is specific for L-amino acids. The trimethylammonium salt (**13**) ($IC_{50}=10.6\mu M$) shows an increase in inhibitory activity over its parent compound (**12b**) ($IC_{50}=14.8\mu M$).

5.7 *N*-2-Hydroxy-2-phenylacetyl derivatives

Table 5.7 Results of biological assay for *N*-2-hydroxy-2-phenylacetyl derivatives

Compound	IF @ 10 μ M	% Inhibition / Activation @ 10 μ M	IC ₅₀ (μ M)
16a	89.8	53.9	9.3
16b	112.2	42.5	11.8
16c	63.6	67.4	7.4
16d	99.1	49.2	10.2
16e	82.3	57.8	8.7
17a	188.9	3.1	161
17b	145.9	25.2	19.8
17c	117.8	39.6	12.6
17d	74.8	61.6	8.1

The *N*-2-hydroxy-2-phenylacetyl derivatives tested do not show much greater activity than the previously tested compounds even though these compounds contain an extra functional group which could possibly enable them to act as bidentate chelators of the

active site metal. Unexpectedly the derivatives in which the hydroxyl functionality is protected as the acetate tend to be better inhibitors than the derivatives which have a free hydroxyl. For example *N*-2-acetoxy-2-phenylacetyl-L-leucine methyl ester (**16c**) has an IC_{50} value of 7.4 μ M, while *N*-2-hydroxy-2-phenylacetyl-L-leucine (**17b**) has an IC_{50} value of 19.8 μ M. This would seem to indicate that the 2-hydroxy is not involved in binding to the active site metal as described by Nishino and Powers for bestatin.¹¹⁷ However these compounds may not be binding to the active site in a similar manner to bestatin since they do not contain a free amino group and thus a direct correlation cannot be assumed. It also must be remembered that the carboxylic acid group of these compounds is protected as the methyl ester and this has been shown to generally increase inhibitor activity in the previous results. If we compare the results observed for compounds (**27a**) ($IC_{50}=1\mu$ M) and (**27b**) ($IC_{50}=1\mu$ M) which have a free 2-hydroxy group but a protected carboxylic acid group we see that they exhibit higher activity than the corresponding compounds with a free hydroxy group and a free carboxylic acid group (**17b**, **17c**) but slightly lesser activity than the compounds where both functional groups are protected (**16c**, **16d**).

It is interesting to note that the two phenethylamide derivatives (**16e**) ($IC_{50}=8.7\mu$ M) and (**17d**) ($IC_{50}=8.1\mu$ M) exhibit relatively good activity even though they are not amino acid derivatives. This again suggests that these compounds are binding in a different manner to bestatin, which requires a free carboxylic acid group for full activity. It is observed as a general trend for the amino acid derivatives that the derivatives of L-leucine (**16c**, **17b**) and L-phenylalanine (**16d**, **17c**) tend to be better inhibitors than those of glycine (**16a**, **17a**) or L-alanine (**16b**). This observation combined with the activity recorded for the phenethylamide derivatives (**16e**, **17d**) suggests that compounds with a bulky alkyl or aryl group can interact more favourably with a hydrophobic pocket in the active site.

5.8 *N*-2-Hydroxy-3-phenylpropionyl derivatives

Table 5.8 Results of biological assay for *N*-2-hydroxy-3-phenylpropionyl derivatives.

Compound	IF @ 10 μ M	% Inhibition / Activation @ 10 μ M	IC ₅₀ (μ M)
20a	101	48.2	10.4
20b	138.4	29	17.2
20c	130.9	32.9	15.2
20d	82.3	57.8	8.7
20e	61.7	68.4	7.3
21a	97.2	50.2	10
21b	117.8	39.6	12.6
21c	87.9	54.9	9.1
21d	71	63.6	7.9
21e	118	39.5	12.7

The biological results of the *N*-2-hydroxy-3-phenylpropionyl derivatives display a very different trend to that observed for the *N*-2-hydroxy-2-phenylacetyl derivatives even though they have a similar structure. This would seem to indicate that the length of the side chain of the α -hydroxy acid moiety is important in determining the best fit of the inhibitors in the active site. Unlike the trend observed for the *N*-2-hydroxy-2-phenylacetyl derivatives, the *N*-2-hydroxy-3-phenylpropionyl derivatives with a free hydroxy functionality (**21a-d**) are better inhibitors than the corresponding compounds in which the 2-hydroxy is protected as the acetate (**20a-d**). However this trend is only true for the amino acid derivatives, for example *N*-2-acetoxy-3-phenylpropionyl phenethylamide (**20e**) (IC₅₀=7.3 μ M) is a better inhibitor than *N*-2-hydroxy-3-phenylpropionyl phenethylamide (**21e**) (IC₅₀=12.7 μ M). It may be that even a slight modification of the side chain may position the inhibitor in the active site in such a way as to allow a greater interaction between the 2-hydroxy group and the

active site metal and also between the free carboxylic acid functionality and some other group in the active site capable of interacting favourably with it.

5.9 *N*-3-Hydroxy-3-phenylpropionyl derivatives

Table 5.9 Results of biological assay for *N*-3-hydroxy-3-phenylpropionyl derivatives.

Compound	IF @ 10 μ M	% Inhibition / Activation @ 10 μ M	IC ₅₀ (μ M)
25a	114	41.5	12
25b	108.5	44.4	11.3
25c	117.9	39.5	12.7
25d	100.9	48.3	10.4
26a	145.9	25.2	19.8
26b	130.9	32.9	15.2
26c	118.1	39.4	12.7

The results of the biological assay for the *N*-3-hydroxy-3-phenylpropionyl derivatives show them to be poorer inhibitors than either their *N*-2-hydroxy-2-phenylacetyl or *N*-3-hydroxy-3-phenylpropionyl counterparts. This is to be expected since it is probable that the distance between the carbonyl and 3-hydroxy functionalities is too great for both of them to interact with the active site metal. For bestatin a 2-hydroxy group is essential for full activity. The trend observed for the *N*-2-hydroxy-2-phenylacetyl derivatives in which greater activity is observed for compounds in which the hydroxy group is protected as the acetate is repeated here, for example *N*-3-acetoxy-3-phenylpropionyl glycine methyl ester (**25a**) has an IC₅₀ value of 12 μ M, while *N*-3-hydroxy-3-phenylpropionyl glycine (**26a**) has an IC₅₀ value of 19.8 μ M.

5.10 N-2-Thio-2-phenylacetyl derivatives

Table 5.10 Results of biological assay for *N*-2-thio-2-phenylacetyl derivatives

Compound	IF @ 10 μ M	% Inhibition / Activation @ 10 μ M	IC ₅₀ (μ M)
27a	97.2	50.2	10
27b	102.9	47.2	10.6
28a	93.5	52.1	9.6
28b	112.1	42.5	11.8
28c	76.7	60.7	8.2
29a	121.6	37.6	13.3
29b	89.8	53.9	9.3
29c	67.3	65.5	7.6
30	7.5	96.2	5.2

The results for the 2-thio-2-phenylacetyl-derivatives show these compounds to be promising starting point for developing potent inhibitors of the malarial aminopeptidase. Unfortunately we were unable to isolate the free thiol derivatives of L-leucine or L-phenylalanine however *N*-2-thio-2-phenylacetyl-phenethylamide (**30**) (IC₅₀=5.2 μ M) the greatest activity of all the compounds prepared in this study. The high activity of this compound is most likely due to a strong interaction between the thiol group and the active site metal. Unlike the structurally related *N*-2-hydroxy-2-phenylacetyl derivatives in which the protected derivative has a greater activity the corresponding thioacetate derivative (**29c**) has a lesser inhibitory activity (IC₅₀=7.6 μ M) and the corresponding mesylate derivative (**28c**) is an even poorer inhibitor (IC₅₀=8.2 μ M) perhaps due to the bulkiness of the methanesulphonyl group. Unfortunately we were unable to isolate the *N*-2-thio-2-phenylacetyl derivatives of leucine and phenylalanine but this type of compound may have

promise as inhibitors of the malarial aminopeptidase. Similar compounds with an α -thioacyl group are known to be potent orally active inhibitors of zinc metalloproteases.¹⁶⁵⁻¹⁶⁸

5.11 Experimental

Experimental note

The cell-free extract of *P. chabaudi* was kindly provided by Dr. John Dalton in the School of Biological Sciences D.C.U. It was obtained from the blood of mice containing early trophozoites, when the parasitemia had reached 15-20%. The blood was chromatographed on a CF11 column to remove white blood cells and platelets, which bind to the column. The collected red blood cells were then washed with phosphate buffered saline (PBS), pH 7.4. The cells were lysed with 0.1% saponin on ice to obtain free parasites. Haemoglobin was removed by centrifugation (15000g for 20min). Cell-free extracts were prepared by three cycles of freeze-thaw lysis followed by centrifugation (15000g for 20min at 4°C). The cell-free extracts were stored at -4°C. In order to simplify the assay procedure we took the average molecular weight of the inhibitors to be 300g mol⁻¹.

Determination of inhibitor activity by Fluorescence assay

A 3.33 x 10⁻³ stock solution of each of the test compounds was prepared by dissolving 1mg of each of the compounds into 1ml of DMF. The cell-free extract of enzyme in PBS (100µL) was added to a solution containing 0.01M L-leucine-AMC in PBS (100µL), 3µl of the stock solution of test compounds (for a final concentration of 10µM), and 800µL PBS, giving a final volume of approximately 1ml. All test solutions were prepared in duplicate. Positive controls containing no inhibitor, as well as negative controls containing 1µM (100µL) bestatin were also prepared. The test solutions were incubated at 37°C for 30min, and the enzyme activity stopped by the addition of 10% acetic acid (200µL). The liberated AMC was determined using a Perkin-Elmer fluorimeter (excitation 370nm, emission 440nm).

CONCLUSION

Many of the compounds that were prepared in this study possessed modest aminopeptidase inhibitory potency in the micromolar range. Some of the compounds were also found to be activators of the enzyme, with the esters of the *N*-3-nitrophthaloyl amino acid derivatives being particularly potent activators of the aminopeptidase. These compounds require further study, since there may be situations in which the activation of aminopeptidases may be a powerful chemotherapeutic tool. Interestingly the *N*- α -hydroxyphenylacyl amino acid derivatives did not show much greater activity than the simpler *N*-cinnamoyl amino acid derivatives even though it was assumed that the presence of the hydroxyl group would allow these compounds to chelate the active site metal in a bidentate ligand with both the hydroxyl and carbonyl functionalities. Unexpectedly for the *N*-2-hydroxy-2-phenylacetyl amino acid derivatives, the compounds in which the hydroxyl group is protected as the acetate are more potent inhibitors than the compounds with a free hydroxyl group. The reverse trend is observed for the *N*-2-hydroxy-3-phenylpropionyl amino acid derivatives. Thus changing the length of the side chain of the α -hydroxyalkoyl moiety may greatly affect the activity of the compound, probably by affecting its binding to the active site. The α -thiophenylacyl derivatives would appear to be the most effective inhibitors prepared in this study, possibly due to a strong complexation between the sulphhydryl group and the active site metal. More work needs to be carried out to fully explain the mode of action of these types of compounds.

REFERENCES

- (1) "Introduction to Parasitology: With Special Reference to the Parasites of Man", 10th Ed., Chandler A.S.A.C., Read C.P., John Wiley & sons, 1961.
- (2) "Introduction to Animal Parasitology", 2nd Ed., Smyth J.D., Hodder & Stoughton, 1976.
- (3) "Pharmacology", 3rd Ed., Rang H.P., Dale M.M. and Ritter J.M., Churchill Livingstone, 1995.
- (4) "Textbook of Pharmacology", 2nd Ed., Bowman W.C., Rand M.J., Blackwell Scientific Publications, 1980.
- (5) "Principles of Pharmacology: Basic Concepts and Clinical Applications", Munson P.L., Chapman & Hall, 1995.
- (6) "Malaria Obstacles and Opportunities, A Report of the Committee for the Study of Malaria Prevention and Control: Status Review and Alternative Strategies", Oaks S.C., Violane S.M., Pearson G.W., Carpenter C.C.J., Division of International Health, Institute of Medicine Washington, National Academy Press, 1991.
- (7) Sherman I.W., Tanigoshi L, *Int. J. Biochem.*, 1971, **1**, 635-637.
- (8) Sherman I.W., *Microbiol. Rev.*, 1979, **43**, 453.
- (9) Morrison D.B., Jeskey H.A., *J. Nat. Malaria Soc.*, 1948, **7**, 259.
- (10) Roth E.F., Brotman D.S., Vanderberg J.P., Schulman S., *Am. J. Trop. Med. Hyg.*, 1986, **35**, 906.
- (11) Goldberg D.E., Slater A.F.G., Beavis R., Chait B., Cerami A., Henderson G.B., *J. Exp. Med.*, 1991, **173**, 961-969.
- (12) Goldberg D.E., Slater A.F.G., *Parasitology Today*, 1992, **8**, 280-283.
- (13) Krogstad D.J., Schlesinger P.H., Gluzman I.Y., *J. Cell. Biol.*, 1985, **101**, 2302-2309.
- (14) Krogstad D.J., Schlesinger P.H., *New Eng. J. Med.*, 1987, **317**, 542-549.
- (15) Vander Jagt D.L., Hunsaker L.A., Campos N.H., *Mol Biochem. Parasitol.*, 1989, **18**, 389-400.
- (16) Vander Jagt D.L., Hunsaker L.A., Campos N.H., *Biochem. Pharmacol.*, 1987, **36**, 3285-3291.
- (17) Sherman I.W., Tanagoshi L., *Mol. Biochem. Parasitol.*, 1983, **8**, 207-226.

- (18) Rosenthal P.J.,McKerrow J.H, Aikawa M., Nagasawa H., Leech J.H, *J. Clin. Invest.*, 1988, **82**, 1560-1566.
- (19) Rosenthal P.J., Kim K., McKerrow J.H, Leech J.H, *J. Exp. Med.*, 1987, **166**, 816-821.
- (20) Curley G.P., O'Donovan S.M., McNally J., Mullally M., O'Hara H., Troy A., O'Callaghan S., Dalton J.P., *J. Euk. Microbiol.*, 1994, **41**, 119.
- (21) "*The Organic Chemistry of Drug Synthesis, Vol I*", Lednicer D., Mitscher L.A., John Wiley & Sons, 1977.
- (22) Woodward R.B., Doering W.E., *J. Am. Chem. Soc.*, 1945, **67**, 860-874.
- (23) White N.J., Warrell D.A., Chanthavanich P., *New Eng. J. Med.*, 1983, **309**, 61-66.
- (24) Taylor T.E., Molyneux M.E., Wirima J.J., Fletcher A., Morris K., *New Eng. J. Med.*, 1988, **319**, 1040-1047.
- (25) Surrey A.R., Hammer H.F., *J. Am. Chem. Soc.*, 1946, **68**, 113-116.
- (26) Chou A.C., Chevli R., Fitch C.D., *Biochemistry*, 1980, **19**, 1543-1549.
- (27) Fitch C.D., Chevli R., Banyal H.S., Phillips G., Pfaller M.A., Krogstad D.J., *Antimicrobial Agents Chemotherapy*, 1982, **21**, 819-822.
- (28) Orjih A.V., Banyal H.S, Chevli R., Fitch C.D., *Science*, 1981, **214**, 667-669.
- (29) Zarchin S., Krugliak M., Ginsburg H., *Biochem. Pharmacol.*, 1986, **35**, 2435-2442.
- (30) Zidovetzki R., Sherman I.W., O'Brien L., *J. Parasitol.*, 1993, **74**, 565-570.
- (31) Shalmiev G., Ginsburg H., *Biochem. Pharmacol.*, 1993, **46**, 365-374.
- (32) Elderfield R.C., Mertel H.E., Mitch R.T., Wempen I.M., Werble E., *J. Am. Chem. Soc.*, 1955, **77**, 4816-4822.
- (33) Butler A.R., Wu Y., *Chem. Soc. Rev.*, 1992, 85-90.
- (34) Hien T.T., White N.J., *Lancet*, 1993, **341**, 603.
- (35) Klayman D.L., *Science*, 1985, **228**, 1049-1055.
- (36) Vennerstrom J.L., Eaton J.W., *J. Med. Chem.*, 1988, **31**, 1269-1277.
- (37) Posner G.H., Wang D., Gerenna L., Milhous K., Meshnick S.R., Asawamahasadka W., *J. Med. Chem.*, 1994, **37**, 1256-1258.
- (38) Van Hensbroek M.B., Onyiorah E., Jaffar S., Schneider G., Palmer A., Frenkel J., Enwere G., Forck S., Nusmeiser A., Bennet S., Greenwood B., Kwiatkowski D., *New Eng. J. Med.*, 1996, **335**, 69-75.

- (39) Hien T.T., Nicholas P.J., Day B.M., Nguyen H.P., Nguyen T.H.M., Chau T.T.H., Pham P.L., Dinh X.S., Chuong L.V., Vinh H., Waller D., Peto T.E.A., White N.J., *New Eng. J. Med.*, 1996, **335**, 76-83.
- (40) Avery M.A., Bonk J.D., Chong W.K.M., Mehrotra S., Miller R., Milhous W., Goins D.K., Venkatesan S., Wyandt C., Khan F., Avery B.A., *J. Med. Chem.*, 1995, **38**, 5038-5044.
- (41) Torok D.S., Ziffer H., Meshnick S.R., Pan X.Q., *J. Med. Chem.*, 1995, **38**, 5045-5050.
- (42) Posner G.H., Oh C.H., Gerena L., Milhous W.K., *J. Med. Chem.*, 1992, **35**, 2459-2467.
- (43) Posner G.H., McGarvey D.J., Oh C.H., Kumar N., Meshnick S.R., Aswaamahasadka W., *J. Med. Chem.*, 1995, **38**, 607-612.
- (44) O'Neill P.M., Bishop L.P., Storr R.C., Hawley S.R., Maggs J.L., Ward S.A., Park K., *J. Med. Chem.*, 1996, **39**, 4511-4514.
- (45) Patarroyo M.E. Amador R., Clavijo P., Moreno A., Guzman F., Romero P., Tascon R., Franco A., Murillo L.A., Ponton G., Gustavo T., *Nature*, 1988, **332**, 158-161.
- (46) Nussenzweig R.S., Zavala F., *New Eng. J. Med.*, 1997, **336**, 128-130.
- (47) Stoute J.A., Slaovi M., Heppner G., Momin P., Kester K.E., Desmons P., Welde B.T., Garcon N., Kzych U., Marchan M., Ballou R., Cohen J.D., *New Eng. J. Med.*, 1997, **336**, 86-91..
- (48) "Enzyme Catalyzed Reactions"
- (49) "Enzyme Structure And Mechanism", Fersht A., W.H. Freeman & Co., 1977.
- (50) "The Enzymes, Vol III, Hydrolysis: Peptide Bonds", 3rd Ed, Boyer P.D., Academic press, 1971.
- (51) "Enzyme Mechanisms", Page M.I., Williams A., The Royal Society of Chemistry, 1987.
- (52) Bryce G.F., Rabin B.R., *Biochem J.*, 1964, **90**, 514-518.
- (53) Umezawa H., Aoyagi T., Morishima H., Matsuzaki M., Hamada M., Takeuchi T., *J. Antibiot.*, 1970, **23**, 259-262.
- (54) Rich Daniel H., Sun E.T., Boparai A.S., *J. Org. Chem.*, 1978, **43**, 3624-3626.
- (55) Rittle K.E., Homnick C.F., Ponticello G.S., Evans B.E., *J. Org. Chem.*, 1982, **47**, 3016-3018.

- (56) Scheibel L.W., Bueding E., Fish W.R., Hawkins J.T., *Prog. Clin. Biol. Res.*, 1984, **155**, 131-141.
- (57) Aoyagi T., Takeuchi T., Matsuzaki A., Kawamura K., Kondo S., Hanada M., Maeda K., Umezawa H., *J. Antibiot.*, 1969, **22**, 283-286.
- (58) Schultz R.M., Varma-Nelson P., Ortiz R., Kozlowski K.A., Orawski A.T., *J. Biol. Chem.*, 1989, **264** (3), 1497.
- (59) Ito A., Takahashi R., Baba Y., *Chem. Pharm. Bull.*, 1975, **23**, 3081-3087.
- (60) Ito A., Takahashi R., Miura C., Baba Y., *Chem. Pharm. Bull.*, 1975, **23**, 3107-3113.
- (61) Saino T., Someno T., Ishii S., Aoyagi T., Umezawa H., *J. Antibiot.*, 1988, **26**, 221-225.
- (62) Someno T., Ishii S., *Chem. Pharm. Bull.*, 1986, **34**, 1748-1754.
- (63) McConnell R.M., Barnes G.E., Hyong C.F., Gunn J.M., *J. Med. Chem.*, 1990, **33**, 86-92.
- (64) McConnell R.M., York J.L., Frizzell D., Ezell C., *J. Med. Chem.*, 1993, **36**, 1084-1089.
- (65) Hanada K., Tamai M., Yamagishi M., Ohmura S., Sawada J., Tanaha I., *Agric. Biol. Chem.*, 1978, **42**, 523-528.
- (66) Hanada K., Tamai M., Ohmura M., Sawada J., Seki T., Tanaka I., *Agric. Biol. Chem.*, 1978, **42**, 529-536.
- (67) Yabe Y., Guillame D., Rich D.H., *J. Am. Chem. Soc.*, 1988, **110**, 4043-4044.
- (68) Meara J.P., Rich D.H., *J. Med. Chem.*, 1996, **39**, 3357-3366.
- (69) Barret A.J., Kembhavi A.A., Brown M.A., Kirschke H., Knight C.G., Tamai M., Hanada K., *Biochem. J.*, 1982, **201**, 189-198.
- (70) Tamai M., Hanada K., Aadachi T., Oguma K., Kashiwagi K., Omura S., Ohzeiki M., *J. Biochem.*, 1981, **90**, 255-257.
- (71) Rosenthal P.J., McKerrow J.H., Rasnick D., Leech J.D., *Mol. Biochem. Parasitol.*, 1989, **35**, 177-183.
- (72) Rosenthal P.J., Wollish W.S., Palmer J.T., Rasnick D., *J. Clin. Invest.*, 1991, **88**, 1467-1472.
- (73) Rasnick D., *Anal. Biochem.*, 1985, **149**, 461.
- (74) Rauber P., Angliker H., Walker B., Shaw E., *Biochem. J.*, 1986, **234**, 633-640.

- (75) Angliker H., Wikstrom P., Rauber P., Shaw E., *Biochem. J.*, 1986, **241**, 871-875.
- (76) Angliker H., Wikstrom P., Rauber P., Stones E., Shaw E., *Biochem. J.*, 1988, **256**, 481-486.
- (77) Kurtz A.N., Nieman C., *J. Org. Chem.*, 1961, **26**, 1843-1846.
- (78) Kurtz A.N., Nieman C., *J. Am. Chem. Soc.*, 1961, **83**, 1879-1882.
- (79) Powers J.C., Carroll D.L., *Biochem. Biophys. Res. Commun.*, 1975, **67**, 639-644.
- (80) Powers J.C., Gupton F., *Methods Enzymol.*, 1977, **46**, 208-216.
- (81) Gupton F.B., Carroll D.L., Tuhy P.M., Kam C., Powers J.C., *J. Biol. Chem.*, 1984, **259**, 4279-4287.
- (82) Powers J.C., Boone R., Carroll D.L., Gupton B.F., Kam C.M., Nishion N., Sakamoto M., Tuhy P.M., *J. Biol. Chem.*, 1984, **259**, 4288-4294.
- (83) Magrath J., Abeles R.H., *J. Med. Chem.*, 1992, **35**, 4279.
- (84) Gante J., *Synthesis*, 1989, 405-413.
- (85) Fournie-Zaluski M., Coric P., Turcaud S., Bruetschy L., Lucas E., Noble F., Roques B.P., *J. Med. Chem.*, 1992, **35**, 1259-1266.
- (86) Helene A., Beaumont A., Roques B.P., *Eur. J. Biochem.*, 1991, **196**, 385.
- (87) Chan W.W.C., *Biochem. Biophys. Res. Commun.*, 1983, **116**, 297-303.
- (88) Weiss B., Hui K.S., Hui M., Lajtha A., *Res. Commun. Chem. Pathol. Pharmacol.*, 1988, **62**, 113-123.
- (89) Ocain T.D., Rich D.H., *Biochem. Biophys Res. Commun.*, 1987, **145**, 1038-1042.
- (90) Chan W.W.C., Dennis P., Demner W., Brand K., *J. Biol. Chem.*, 1982, **257**, 7955-7959.
- (91) Oleksyszyn J., Subotkowska L., Mastalerz P., *Synthesis*, 1979, 985-986.
- (92) Oleksyszyn J., Subotkowska L., *Synthesis*, 1980, 906.
- (93) Duggan M.E., Karanewsky D.S., *Tetrahedron Lett.*, 1983, **24**, 2935-2938.
- (94) Giannousis P.P., Bartlett P.A., *J. Med. Chem.*, 1987, **30**, 1603-1609.
- (95) Lejczak B., Kafarski P., Zygmunt J., *Biochemistry*, 1989, **28**, 3549-3555.
- (96) Wilkes S.H., Prescott J.M., *J. Biol. Chem.*, 1983, **258**, 13517-13521.
- (97) Baker J.O., Wilkes S.H., Bayliss M.E., Prescott J.M., *Biochemistry*, 1983, **22**, 2098-2103.
- (98) Blumberg S., Vogel Z, Alstein M., *Life Sci.*, 1981, **28**, 301-303.

- (99) Colletti-Previero M.A., Crastes de Paulet A., Mattas M., Previero A., *Biochem. Biophys. Res. Commun.*, 1982, **107**, 465-469.
- (100) Andersson L., Isley T.C., Wolfenden R., *Biochemistry*, 1982, **21**, 4177-4180.
- (101) Umezawa H., Aoyagi T., Suda H., Hamada M., Takeuchi T., *J. Antibiot.*, 1976, **29**, 97.
- (102) Umezawa H., Ishizuka M., Aoyagi T., Suda H., Hamada M., Takeuchi T., *J. Antibiot.*, 1976, **29**, 857-859.
- (103) Ricci J.S., Bousuaros A., Taylor A., *J. Org. Chem.*, 1982, **47**, 3063-3065.
- (104) Kobayashi S., Isobe T., Ohno M., *Tetrahedron Lett.*, 1984, **25**, 5079-5082.
- (105) Nishizawa R., Saino T., Susuzi M., Fujii T., Shirai T., Aoyagi T., Umezawa H., *J. Antibiot.*, 1983, **36**, 695-699.
- (106) Kato K, Saino T., Nishizawa R., Takita T., Umezawa H., *J. Chem Soc. Perkin Trans. I*, 1980, 1618-1621.
- (107) Suda H., Takita T., Aoyagi T., Umezawa H., *J. Antibiot.*, 1976, **24**, 600-601.
- (108) Sharpless K.B., Behrens C.H., Katsuki T., Lee A.W.M., Martin V.S., Taketani M., Viti S.M., Walker F.J., Woodard S.S, *Pure & Applied Chem.*, 1983, **55**, 589-604.
- (109) Palomo C., Arrieta A., Cossio F.P., Aizpurura J.M., Mielgo A., Aurrekoetxea N., *Tetrahedron Lett.*, 1990, **31**, 6429-6432.
- (110) Pearson W.H., Hines J.V., *J. Org. Chem.*, 1989, **54**, 4235-4237.
- (111) Aoyagi T., Tobe H., Kojma F., Hamada M., Takeuchi T., Umezawa H., *J. antibiot.*, 1979, **31**, 636-638.
- (112) Rich D.H., Moon B.J., Boparai A.S., *J. Org. Chem.*, 1980, **45**, 2288-2290.
- (113) Wilkes S.H., Prescott J.M., *J. Biol Chem.*, 1985, **260**, 13154-13162.
- (114) Rich D.H., Moon B.J., Harbeson S., *J. Med. Chem.*, 1984, **27**, 417-422
- (115) Harbeson S.L., Rich D.H., *Biochemistry*, 1988, **27**, 7301.
- (116) Nishizawa R., Saino T., Takita T., Suda H., Aoyagi T., Umezawa H., *J. Med. Chem.*, 1977, **20**, 510-515.
- (117) Nishino N., Powers J.C., *Biochemistry*, 1979, **18**, 4340-4347.
- (118) Gordon E.M., Godfrey J.D., Delaney N.G., Asaad M.M., Von Langen D., Cushman D.W., *J. Med. Chem.*, 1988, **31**, 2199-2211.
- (119) Ocain T.D., Rich D.H., *J. Med. Chem.*, 1988, **31**, 2193-2199.

- (120) Herranz R., Vinuesa S., Castro-Pichel J., Perez C., Garcia-Lopez M.T., *J. Chem. Soc. Perkin Trans. I*, 1992, 1825-1830.
- (121) "Vogels Textbook of Practical Organic Chemistry", 5th Ed., Furniss B.P., Hannaford A.J., Smith, P.W.G., Tatchell A.R., Longman Scientific & Technical U.K., 1989.
- (122) "Organic Synthesis Collected Volumes, Vol III", Horning, John Wiley & Sons, 1955.
- (123) "Principles of Peptide Synthesis", 2nd Ed., Bodansky M., Springer-Verlag, 1993.
- (124) "The Practice of Peptide Synthesis", 2nd Ed., Bodansky M., Bodansky A., Springer-Verlag, 1994.
- (125) "Protecting Groups in Organic Synthesis", Green
- (126) Bosshard H.H., Mory R., Schmid M., Zollinger Hch., *Helv. Chim. Acta.*, **42**, 1653.
- (127) Vilsmeier, Haack, *Chem. Ber.*, 1927, **60B**, 119.
- (128) Brown H.C., Mead E.J., Subba Rao B.C., 1955, *J. Org. Chem.*, 6209-6213.
- (129) "Experiments and Techniques in Organic Chemistry", Pasto D., Johnson C., Miller M., Prentice Hall, 1992.
- (130) Lynch B.M., Pausacker K.H., *J. Chem. Soc.*, 1955, 1525.
- (131) Bunton C.A., Minkoff G.J., *J. Chem. Soc.*, 1949, 665.
- (132) Klausner Y.S., Bodansky M., *Synthesis*, 1972, 453-463.
- (133) "An Introduction to Peptide Chemistry", Bailey, John Wiley & Sons, 1990.
- (134) König W., Geiger R., *Chem. Ber.*, 1970, **103**, 788-798.
- (135) Ronwin E., *J. Org. Chem.*, 1953, **18**, 127.
- (136) Ronwin E., *J. Org. Chem.*, 1953, 1546.
- (137) Biemann K., *Methods Enzymol.*, 1983, **90**, 487-489.
- (138) Brenner H., Huber W., *Helv. Chim. Acta.*, 1953, **36**, 1109.
- (139) "Dictionary of Organic Compounds, Vol. I", 4th Ed, Oxford University Press, Eyre & Spottiswoode Ltd, 1965.
- (140) Fiez-Vandal P., *Eur Pat. Appl.*, (C1CO7K5/08), 1989.
- (141) Lipschutz B.H., Hungate R.W., McCarthy K.E., *J. Am. Chem. Soc.*, 1983, **105**, 7703-7713.
- (142) Kortt A.A., Liu T., *Biochemistry*, 1973, **12**, 328-337.
- (143) Arutyunyan A., *Khim. Farm. Zh.*, 1989, **23**, 1223-1226.

- (144) Hyun M.H., Baik I., Pirkle W.H., *J. Liq. Chrom.*, 1988, **11**, 1249-1259.
- (145) Hyun M., Ryoo J., Min C., Pirkle W.H., *Bull. Korean Chem. Soc.*, 1992, **13**, 407-412.
- (146) El-Nagger A.M., Badie M.F.A., *Egypt J. Chem.*, 1978, **21**, 315-318.
- (147) Kuhn R., Ruelius H.W., *Chem. Ber.*, 1952, **85**, 38-48.
- (148) Berger A., Schechter I., *Phil. Trans. Roy. Soc. Lond. B*, 1970, **257**, 249.
- (149) "Organic Synthesis Collected Volumes, Vol I", Horning., John Wiley & Sons.
- (150) Urban F.J., Moore B.S., *J. Heterocyclic Chem.*, 1992, **29**, 431-438.
- (151) Schlamowitz M., Shaw A., Jackson W.T., *J. Biol. Chem.*, 1968, **243**, 2821-2828.
- (152) Hodgins D.S., *J. Biol Chem.*, 1971, **246**, 2977-2985.
- (153) "Advanced Organic Chemistry: Reactions, Mechanisms and Structure.", 4th Ed., Marsh J., John Wiley and Sons, 1992.
- (154) Brenneisen R., Geisshüler S., Schorno X., *Planta Med.*, 1984, **198**, 531.
- (155) Wolf J.P., Pfander H., *Helv. Chim. Acta*, 1984, **69**, 918-926.
- (156) Waldemar A., Brünker H.G., *Synthesis*, 1995, 1066-1068.
- (157) Hann M.M., Samess P.G., Kennewell P.D., Taylor J.B., *J. Chem. Soc Perkin Trans. I*, 1982, 307-314.
- (158) Hanson G.J., Lindberg T., *J. Org. Chem.*, 1985, **50**, 5399-5401.
- (159) Kametani T., Kigasawa K., Hiragi M., Wagatsuma W., Kohagisawa T., Inoue H., *Heterocycles*, 1997, **7**, 919-925.
- (160) Bateman R.C., Rodriguez G., Vijayaraghavan J., Hersh L.B., *Arch. Biochem. Biophys.*, 1990, **279**, 355-362.
- (161) Yu R.J., Scott E.J., *Int. Pat. Appl. CIC07C 69176*, 1985.
- (162) Latt S.A., Auld D.S., Vallee B.L., *Anal. Biochem.*, 1972, **50**, 56-62.
- (163) Holtzman E.J., Pillay G., Rosenthal T., Yaron A., *Anal. Biochem.*, 1987, **162**, 476-484.
- (164) Taylor A., *FASEB J.*, 1993, **7**, 290-298.
- (165) Robl J.A., Simpkins L.M., Stevenson J., Sun C.Q., Murugesan N., Barrish J.C., Asaad M.M., Bird J.E., Schaeffer T.R., Trippodo N.C., Petrillo E.W., Karanewsky, *Bioog. Med. Chem. Lett.*, 1994, **4**, 1789-1794.
- (166) Bhagwat S.S., Fink C.A., Gude C., Chan K., Qiao Y., Sakane Y., Berry C., Ghai R.D., *Bioog. Med. Chem. Lett.*, 1995, **5**, 735-738.

(167) Fink C.A, Qaio Y., Berry C.J., Sakane Y., Ghai R.D., Trapani A.J., *J. Med. Chem.*, 1995, **38**, 5023-5030.

(168) Fink C.A., Carlson J.E., McTaggart P.A., Qaio Y., Webb R., Chatelain R., Jeng A.Y., Trapani A.J., *J. Med. Chem.*, 1996, **39**, 3158-3168.

APPENDIX I
LIST OF ABBREVIATIONS USED

AHBA	α -Hydroxy- β -amino acid
AHPB	2-Hydroxy-3-amino-4-phenylbutanoic acid
AMC	7-Amino-4-methyl-coumarin
APN	Aminopeptidase N
BOC	<i>t</i> -Butyloxycarbonyl
<i>m</i>-CPBA	<i>meta</i> -Chloroperoxybenzoic acid
DCM	Dichloromethane
DCCD	1, 3-Dicyclohexylcarbodiimide
DIBAL	Diisobutylaluminium hydride
DMF	<i>N, N</i> -Dimethylformamide
Et₃N	Triethylamine
EtOH	Ethanol
MeOH	Methanol
MsCl	Methanesulphonyl chloride
THF	Tetrahydrofuran
Z	Benzyloxycarbonyl

APPENDIX II
PUBLICATION

***N-H*···*O* intramolecular and *O-H*···*O*, *C-H*···*O* and *sp*³ *C-H*··· π (arene) intermolecular interactions in (2*S*)-2-[(2*R*)-2-hydroxy-2-phenylethanoyl]amino}-4-methylpentanoic acid.**

Dalton J.P., Gallagher J.F., Kenny P.T.M. and O'Donohoe M., *Acta Cryst.*, Section C (in press).

APPENDIX III
CRYSTALLOGRAPHIC DATA

28 May 1997

Note: This manuscript has been generated automatically from a Crystallographic Information File by the IUCr *ciftex* program. This program is still under development, and authors, Coeditors and reviewers are advised that some aspects of formatting and data presentation are still not handled in an optimal manner. Features which require further work include suppression of redundant cell parameters (*e.g.* α , γ in monoclinic space groups), full formatting of reference list, and the placement of the experimental text. Note also that compound name identifiers are derived from the arbitrary data block names within the CIF; these are liable to be changed. Please indicate any necessary changes for implementation by *Acta* editorial staff.

Acta Cryst. (1997). C53, 000–000

***N*-3,5-dinitrobenzoyl-*L*-leucine**

JOHN F. GALLAGHER,^a PETER T. M. KENNY,^a MICHAEL O'DONOHUE^a AND
GEORGE FERGUSON^b

^a*School of Chemical Sciences, Dublin City University, Dublin 9, Ireland, and*

^b*Department of Chemistry and Biochemistry, University of Guelph, Guelph,
Ontario, Canada, N1G 2W1. E-mail: gallaghj@ccmail.dcu.i.e*

Abstract

The title compound, C₁₃H₁₅N₃O₇, crystallises as two independent molecules which differ in conformation. Intermolecular hydrogen bonding arises between the amide and carboxylic acid groups as N—H···O=C forming one-dimensional chains, (N···O 2.966 (7) Å, 3.019 (7) Å) and C=O···H—O interactions forming a two-dimensional network by linking neighbouring chains, (O···O 2.675 (8) Å, 2.778 (7) Å).

Comment

The study of biologically important molecules continues to be of primary importance in medicinal chemistry. Processes such as blood coagulation, hormone processing, viral replication and cancer cell invasion are critically dependent on protease enzymes which are attractive target molecules in the design of specific

and selective drugs, (Testa, Kyburz, Fuhrer & Giger, 1993). Important protease inhibitors are usually based on modified amino acids incorporating structural features which determine normal enzyme-substrate recognition processes. Structure-based drug design strategies to identify interactions between a potential inhibitor and target receptor require accurate inhibitor structures. We are currently studying structure activity relationships and molecular recognition processes in biologically important molecules such as N-3,5-dinitrobenzoyl-L-leucine, $C_{13}H_{15}N_3O_7$, (I), for applications in drug design.

In the crystal structure of (I), two independent molecules in the asymmetric unit differ in conformation in the chiral space group P1. Similar views of the two independent molecules A and B with our numbering scheme are given in Figs. 1a and 1b. The bond lengths (Table 2) are in accord with anticipated values (Orpen *et al.*, 1994). The molecules differ in conformation about the N1—C2 bond with the largest angle difference is N1—C2—C4, $115.9(5)^\circ$, $110.0(5)^\circ$ and the torsion angle C1—N1—C2—C3 is $56.1(7)^\circ$, $-81.5(7)^\circ$ in A, B respectively.

The aromatic C1—C11—C12 and C1—C11—C16 angles are $\{123.2(6)^\circ, 116.7(6)^\circ, A\}$ and $\{125.6(5)^\circ, 116.6(5)^\circ, B\}$ resulting from the intramolecular interactions H16A \cdots O5A 2.45 Å, H1A \cdots H12A 2.08 Å in A, H16B \cdots O5B 2.42 Å and H1B \cdots H12B 2.14 Å in B, (O5B \cdots H2B 2.48 Å). The aromatic ring planes are oriented at angles of $19.1(4)^\circ$, $12.8(6)^\circ$ to their respective amide groups (O5,C1,N1,C2) with all nitro groups almost co-planar ($< 10^\circ$ from the ring planes); the carboxylate (C2,C3,O6,O7) groups are almost normal to (C11,C1,C5,N1,C2) $85.9(2)^\circ$, $79.1(2)^\circ$ in A and B respectively.

The molecules align in one dimensional chains as $[A..]_n$ and $[B..]_n$ due to the partial π - π stacking of the 3,5-dinitrobenzoyl groups. Intermolecular hydrogen bonding along the $[A..]_n$ and $[B..]_n$ chains results from amide $[_{A/B}]N-H\cdots O=C[_{A/B}]$ carboxylate interactions with N \cdots O distances of $2.966(7)$ Å {for $[A..]_n$ } and $3.019(7)$ Å {for $[B..]_n$ }. Interactions between the neighbouring A and B chains arises as carboxylate $[_{A/B}]O-H\cdots O=C[_{B/A}]$ amide bonding with O \cdots O distances of $2.675(8)$ Å (A \rightarrow B) and $2.778(7)$ Å (B \rightarrow A).

This combination of hydrogen bonding results in the formation of two 20-membered hydrogen bonded ring systems each consisting of two A and two B

molecules, {J, K in Fig. 2}, differing by $[B..]_n \rightarrow [A..]_n$ (J) and $[A..]_n \rightarrow [B..]_n$ (K) (where \rightarrow indicates the carboxylic acid to amide $O=C$ hydrogen bonds). Each cyclical arrangement consists of four hydrogen bonds listed as, (clockwise in Fig. 2 from the centre): J, $O6B-H2 \cdots O5A$, $N1A-H1A \cdots O7A^i$, $^iO6B-H2 \cdots O5A^i$, $^iN1B-H1B \cdots O7B$ and K, $O6A-H1 \cdots O5B^{ii}$, $^{iii}N1B-H1B \cdots O7B^{ii}$, $^iO6A-H1 \cdots O5B^{iii}$, $N1A-H1A \cdots O7A^i$, {i, $1+x, y, z$; ii, $x, 1+y, z$; iii, $1+x, 1+y, z$ }. The rings have the graph set $R^4_4(20)$ J, $R'^4_4(20)$ K, which repeats as a two-dimensional network in the lattice. Examination of the structure with *PLATON* (Spek, 1996a) showed that there were no solvent accessible voids.

The structure of (L)-Leucine (L-Leu) has been reported previously, (Harding & Howieson, 1976; *Collect*, Solans, Font-Altaba & Subirana, 1986; Görbitz & Dalhus, 1996) and contains two crystallographically independent zwitterion molecules having similar conformations in the asymmetric unit, unlike (I) above, where the two molecules differ significantly in conformation.

Experimental

N-3,5-dinitrobenzoyl-L-leucine was synthesised by the reaction of 3,5-dinitrobenzoyl chloride with the parent (L)-leucine. Recrystallisation from ethanol/water afforded colourless plate-like crystals suitable for X-ray analysis.

m.p. 178–180°C (uncorrected), 187° (Vogel, 1989). i.r. ν_{\max} (KBr): 3400, 1725, 1650, 1550, 1350 cm^{-1} . ^1H NMR data (400 MHz) (δ , DMSO): 0.87–0.94 (6H, d, $J = 6.4\text{Hz}$, $\text{C}(\text{CH}_3)_2$), 1.59–1.82 (3H, m, CH_2CH), 4.47–4.53 (1H, m, NCHCO_2), 8.38 (1H, d, $J = 7.9\text{Hz}$, NH), 8.96 (1H, t, $J = 2\text{Hz}$, ArH *para*-), 9.10 (2H, d, $J = 2\text{Hz}$, ArH *ortho*-).

Crystal data $C_{13}H_{15}N_3O_7$ $M_r = 325.28$

Triclinic

P1

 $a = 5.8046(3) \text{ \AA}$ $b = 10.640(2) \text{ \AA}$ $c = 12.9556(14) \text{ \AA}$ $\alpha = 109.428(11)^\circ$ $\beta = 102.416(7)^\circ$ $\gamma = 90.250(8)^\circ$ $V = 734.44(15) \text{ \AA}^3$ $Z = 2$ $D_x = 1.471 \text{ Mg m}^{-3}$ D_m not measuredMo $K\alpha$ radiation $\lambda = 0.7107 \text{ \AA}$ *Data collection*

Enraf-Nonius CAD-4 diffractometer

 ω - 2θ scans

Absorption correction: none

2621 measured reflections

2621 independent reflections

1326 reflections with

 $I > 2\sigma(I)$ $\theta_{\max} = 25.1^\circ$

Cell parameters from 25 reflections

 $\theta = 9.3\text{--}22.0^\circ$ $\mu = 0.121 \text{ mm}^{-1}$ $T = 294(1) \text{ K}$

Plate

 $0.30 \times 0.20 \times 0.05 \text{ mm}$

Colorless

Crystal source: synthesized by the
authors, see text $h = 0 \rightarrow 6$ $k = -12 \rightarrow 12$ $l = -15 \rightarrow 14$

3 standard reflections

frequency: 60 min

intensity decay: no decay, variation

1.0%

*Refinement*Refinement on F^2

$$R[F^2 > 2\sigma(F^2)] = 0.0449$$

$$wR(F^2) = 0.0798$$

$$S = 0.934$$

2621 reflections

417 parameters

riding (C—H 0.93 to 0.98, N—H 0.86,

O—H 0.82 Å)

$$w = 1/[\sigma^2(F_o^2) + (0.0248P)^2 + 0.0000P]$$

$$\text{where } P = (F_o^2 + 2F_c^2)/3$$

$$(\Delta/\sigma)_{\max} < 0.001$$

$$\Delta\rho_{\max} = 0.188 \text{ e } \text{Å}^{-3}$$

$$\Delta\rho_{\min} = -0.182 \text{ e } \text{Å}^{-3}$$

Extinction correction: *SHELXL93*

Extinction coefficient: 0.0112 (18)

Scattering factors from *International Tables for Crystallography* (Vol. C)Absolute configuration: Flack, H. D. (1983), *Acta Cryst.* A39, 876-881

Flack parameter = 0.25 (159)

Table 1. *Fractional atomic coordinates and equivalent isotropic displacement parameters (\AA^2)*

$$U_{\text{eq}} = (1/3)\sum_i\sum_j U^{ij} a_i^* a_j^* \mathbf{a}_i \cdot \mathbf{a}_j.$$

	<i>x</i>	<i>y</i>	<i>z</i>	U_{eq}
O1A	0.4818 (9)	0.7249 (5)	0.0375 (7)	0.072 (2)
O2A	0.6293 (8)	0.6808 (5)	0.1891 (6)	0.0659 (15)
O3A	0.1297 (10)	0.4481 (6)	0.3281 (6)	0.074 (2)
O4A	-0.2254 (11)	0.3699 (5)	0.2305 (6)	0.077 (2)
O5A	-0.5199 (7)	0.4204 (4)	-0.1304 (5)	0.0490 (12)
O6A	-0.5216 (7)	0.7293 (5)	-0.1954 (6)	0.0576 (15)
O7A	-0.8416 (8)	0.5861 (5)	-0.2652 (6)	0.0562 (14)
N1A	-0.2786 (8)	0.4975 (4)	-0.2161 (6)	0.0333 (12)
N13A	0.4699 (10)	0.6702 (6)	0.1060 (7)	0.048 (2)
N15A	-0.0309 (13)	0.4234 (6)	0.2424 (7)	0.060 (2)
C1A	-0.3211 (12)	0.4608 (6)	-0.1319 (7)	0.037 (2)
C2A	-0.4676 (10)	0.5118 (6)	-0.3072 (7)	0.038 (2)
C3A	-0.6340 (12)	0.6104 (7)	-0.2540 (6)	0.037 (2)
C4A	-0.6006 (10)	0.3821 (6)	-0.3917 (7)	0.044 (2)
C5A	-0.4494 (13)	0.2787 (7)	-0.4486 (7)	0.059 (2)
C6A	-0.2926 (13)	0.3304 (7)	-0.5070 (8)	0.071 (2)
C7A	-0.6156 (15)	0.1592 (7)	-0.5321 (8)	0.078 (3)
C11A	-0.1180 (11)	0.4819 (6)	-0.0320 (7)	0.0296 (15)
C12A	0.0896 (11)	0.5607 (6)	-0.0128 (7)	0.043 (2)
C13A	0.2543 (12)	0.5850 (6)	0.0868 (7)	0.037 (2)
C14A	0.2275 (11)	0.5394 (6)	0.1706 (7)	0.042 (2)
C15A	0.0152 (12)	0.4649 (6)	0.1501 (7)	0.040 (2)
C16A	-0.1583 (11)	0.4360 (6)	0.0511 (6)	0.040 (2)
O1B	-1.6661 (8)	0.2242 (5)	0.0248 (6)	0.0557 (14)
O2B	-1.6925 (8)	0.1932 (5)	0.1787 (6)	0.0589 (14)
O3B	-1.1085 (9)	-0.0491 (5)	0.3425 (6)	0.061 (2)
O4B	-0.8510 (9)	-0.1480 (5)	0.2506 (6)	0.063 (2)

O5B	-0.7999 (8)	-0.0957 (4)	-0.0924 (5)	0.0496 (13)
O6B	-0.8681 (7)	0.2087 (4)	-0.2207 (6)	0.0542 (13)
O7B	-0.5688 (8)	0.0807 (5)	-0.2515 (6)	0.0569 (14)
N1B	-1.0817 (8)	-0.0113 (5)	-0.1938 (6)	0.0357 (13)
N13B	-1.6006 (10)	0.1758 (6)	0.0983 (6)	0.048 (2)
N15B	-1.0197 (11)	-0.0801 (6)	0.2613 (7)	0.048 (2)
C1B	-0.9894 (11)	-0.0440 (6)	-0.1033 (7)	0.033 (2)
C2B	-0.9562 (10)	-0.0261 (6)	-0.2828 (7)	0.038 (2)
C3B	-0.7752 (11)	0.0901 (7)	-0.2526 (7)	0.040 (2)
C4B	-1.1330 (11)	-0.0490 (7)	-0.3946 (7)	0.040 (2)
C5B	-1.2653 (12)	-0.1887 (7)	-0.4399 (7)	0.052 (2)
C6B	-1.1159 (14)	-0.2964 (7)	-0.4946 (8)	0.083 (3)
C7B	-1.4961 (13)	-0.1930 (9)	-0.5244 (9)	0.093 (3)
C11B	-1.1189 (11)	-0.0163 (6)	-0.0119 (6)	0.032 (2)
C12B	-1.3045 (11)	0.0650 (6)	0.0003 (7)	0.037 (2)
C13B	-1.3966 (10)	0.0937 (6)	0.0917 (7)	0.0308 (15)
C14B	-1.3120 (11)	0.0488 (6)	0.1787 (7)	0.038 (2)
C15B	-1.1245 (12)	-0.0304 (6)	0.1683 (6)	0.035 (2)
C16B	-1.0270 (10)	-0.0645 (5)	0.0764	0.032 (2)

Table 2. *Selected geometric parameters* (\AA , $^\circ$)

O5A—C1A	1.236 (7)	O5B—C1B	1.234 (7)
O6A—C3A	1.321 (7)	O6B—C3B	1.345 (7)
O7A—C3A	1.199 (7)	O7B—C3B	1.200 (7)
N1A—C1A	1.343 (7)	N1B—C1B	1.337 (7)
N1A—C2A	1.478 (6)	N1B—C2B	1.458 (7)
C1A—C11A	1.505 (8)	C1B—C11B	1.486 (8)
C2A—C3A	1.524 (8)	C2B—C3B	1.509 (8)
C2A—C4A	1.523 (7)	C2B—C4B	1.528 (7)

C1A—N1A—C2A	123.4 (5)	C1B—N1B—C2B	121.8 (5)
N1A—C2A—C3A	108.3 (5)	N1B—C2B—C3B	111.6 (5)
N1A—C2A—C4A	115.9 (5)	N1B—C2B—C4B	110.0 (5)
C3A—C2A—C4A	112.1 (5)	C3B—C2B—C4B	113.0 (5)
O6A—C3A—O7A	123.5 (6)	O6B—C3B—O7B	122.7 (6)
O6A—C3A—C2A	111.2 (5)	O6B—C3B—C2B	112.3 (5)
O7A—C3A—C2A	125.2 (6)	O7B—C3B—C2B	125.0 (6)
C2A—C4A—C5A	115.7 (5)	C2B—C4B—C5B	111.5 (5)
C1A—C11A—C12A	123.2 (6)	C1B—C11B—C12B	125.6 (5)
C1A—C11A—C16A	116.7 (6)	C1B—C11B—C16B	116.6 (5)
C2A—N1A—C1A—O5A	8.9 (9)	C2B—N1B—C1B—O5B	-4.3 (9)
C2A—N1A—C1A—C11A	-165.9 (5)	C2B—N1B—C1B—C11B	175.2 (5)
C1A—N1A—C2A—C3A	56.1 (7)	C1B—N1B—C2B—C3B	-81.5 (7)
C1A—N1A—C2A—C4A	-70.8 (7)	C1B—N1B—C2B—C4B	152.2 (5)
N1A—C2A—C3A—O7A	-120.7 (6)	N1B—C2B—C3B—O7B	124.8 (7)
C4A—C2A—C3A—O7A	8.4 (9)	C4B—C2B—C3B—O7B	-110.5 (7)
N1A—C2A—C3A—O6A	61.2 (6)	N1B—C2B—C3B—O6B	-52.0 (7)
C4A—C2A—C3A—O6A	-169.7 (5)	C4B—C2B—C3B—O6B	72.7 (7)
N1A—C2A—C4A—C5A	-55.1 (7)	N1B—C2B—C4B—C5B	-71.3 (7)
C3A—C2A—C4A—C5A	179.9 (5)	C3B—C2B—C4B—C5B	163.2 (6)
C2A—C4A—C5A—C6A	-55.5 (8)	C2B—C4B—C5B—C6B	-78.4 (7)
C2A—C4A—C5A—C7A	-178.2 (6)	C2B—C4B—C5B—C7B	159.2 (6)

Table 3. *Hydrogen-bonding geometry* (\AA , $^\circ$)

$D-H \cdots A$	$D-H$	$H \cdots A$	$D \cdots A$	$D-H \cdots A$
N1A—H1A \cdots O7A ⁱ	0.86	2.15	2.966 (7)	158
O6A—H1 \cdots O5B ⁱⁱ	0.82	1.86	2.675 (8)	173
N1B—H1B \cdots O7B ⁱⁱⁱ	0.86	2.17	3.019 (7)	168
O6B—H2 \cdots O5A	0.82	1.97	2.778 (7)	166

Symmetry codes: (i) $1 + x, y, z$; (ii) $x, 1 + y, z$; (iii) $x - 1, y, z$.

Molecule (I) crystallised in the triclinic system; space group P1 or P-1; the molecule is chiral, space group P1 chosen and confirmed by the analysis. The absolute configuration is based on L-leucine. The plate diffracted weakly but sufficient data were collected to establish the structure and elucidate the hydrogen bonding interactions in the crystal structure.

Data collection: CAD-4 (Enraf-Nonius, 1992). Cell refinement: *SET4* & *CELDIM* (Enraf-Nonius, 1992). Data reduction: *DATRD2* in *NRCVAX94* (Gabe, Le Page, Charland, Lee & White, 1989). Program(s) used to solve structure: *SHELXS86* (Sheldrick, 1986). Program(s) used to refine structure: *NRCVAX94* and *SHELXL93* (Sheldrick, 1993). Molecular graphics: *NRCVAX94*, *ORTEP* (Johnson, 1976), *PLATON* (Spek, 1996*a*), *PLUTON* (Spek 1996*b*). Software used to prepare material for publication: *NRCVAX94*, *SHELXL93* and *WordPerfect* macro PREPCIF (Ferguson, 1997).

G. F. thanks NSERC (Canada) for Research Grants and J. F. G. thanks the Research and Postgraduate Committee of Dublin City University for partial funding (Research Grant No. RC96-SRAF-06JG) of a research visit to the University of Guelph (July -August, 1996).

Supplementary data for this paper are available from the IUCr electronic archives (Reference: PRINTCIF). Services for accessing these data are described at the back of the journal.

References

- Collect, M., Solans, X., Font-Altaba, M. & Subirana, J. A. (1986). *Acta Cryst.* C42, 599–601.
- Enraf-Nonius (1992). CAD-4-PC Software, Version 1.1. Enraf-Nonius, Delft, Holland.
- Ferguson, G. (1997). PREPCIF - a *WordPerfect*-5.1 macro to merge and polish CIF format files from *NRCVAX94* and *SHELXL93* programs. University of Guelph, Canada.
- Flack, H. D. (1983). *Acta Cryst.* A39, 876–881.
- Gabe, E. J., Le Page, Y., Charland, J.-P., Lee F. L. & White, P. S. (1989). *J. Appl. Cryst.* 22, 384–387.
- Görbitz, C. H. & Dalhus, B. (1996). *Acta Cryst.* C52, 1754–1756.
- Harding, M. M. & Howieson, R. M. (1976). *Acta Cryst.* B32, 633–634.
- Johnson, C. K. (1976). *ORTEP* - A Fortran Thermal Ellipsoid Plot Program, Technical Report ORNL-5138, Oak Ridge National Laboratory, USA.
- Orpen, A. G., Brammer, L., Allen, F. H., Kennard, O., Watson, D. G. & Taylor, R. (1994). Appendix A of Structure Correlations, Vol. 2. Editors. H.-B. Bürgi and J. D. Dunitz, VCH *Publ.* Weinheim, Germany.
- Sheldrick, G. M. (1986). *SHELXS86*. Program for the solution of crystal structures. University of Göttingen, Germany.
- Sheldrick, G. M. (1993). *SHELXL93*. Program for the refinement of crystal structures. University of Göttingen, Germany.
- Spek, A. L. (1996a). *PLATON* Molecular Geometry Program, August, 1996 version. University of Utrecht, Utrecht, Holland.
- Spek, A. L. (1996b). *PLUTON* Molecular Graphics Program, August, 1996 version. University of Utrecht, Utrecht, Holland.
- Testa, B., Kyburz, E., Fuhrer W. & Giger, R. (1993). Editors. Perspectives in

Medicinal Chemistry, VCH *Publ.* Weinheim, Germany.

Vogel, A. I. (1989). *Textbook of Practical Organic Chemistry*, 5th Edition, Furniss, B. S., Hannaford, A. J., Smith, P. W. G. & Tatchell, A. R., Editors. Longman Scientific & Technical.

Fig. 1a. A view of A with our numbering scheme. Displacement ellipsoids are drawn at the 30% probability level.

Fig. 1b. A view of B with our numbering scheme. Displacement ellipsoids are drawn at the 30% probability level.

Fig. 2. A view of the hydrogen-bonding interactions in compound (I). The nitro groups and *para*-H atoms have been removed from molecules A and B in the asymmetric unit (labelled as *). All H atoms except for the amide NH in the four symmetry related molecules were removed for clarity. Displacement ellipsoids for the non-H atoms were drawn at the 30% probability level and the O and N atoms of A are drawn with cross-hatched thermal ellipsoids.

Table 1. Fractional atomic coordinates and equivalent isotropic displacement parameters (\AA^2) for compound (I)

Table 2. Selected geometric parameters (\AA , $^\circ$) for compound (I)

Table 3. Hydrogen bond parameters (\AA , $^\circ$) for compound (I)

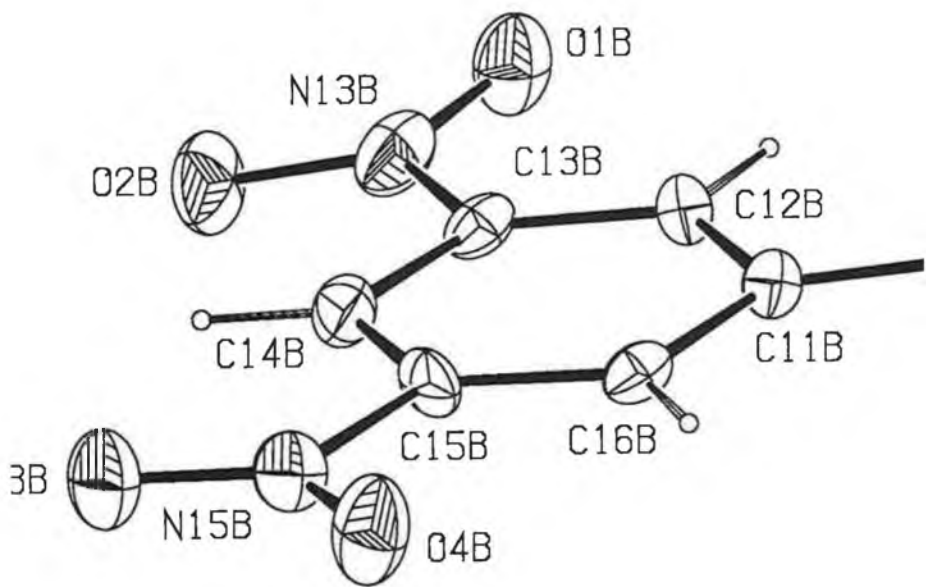

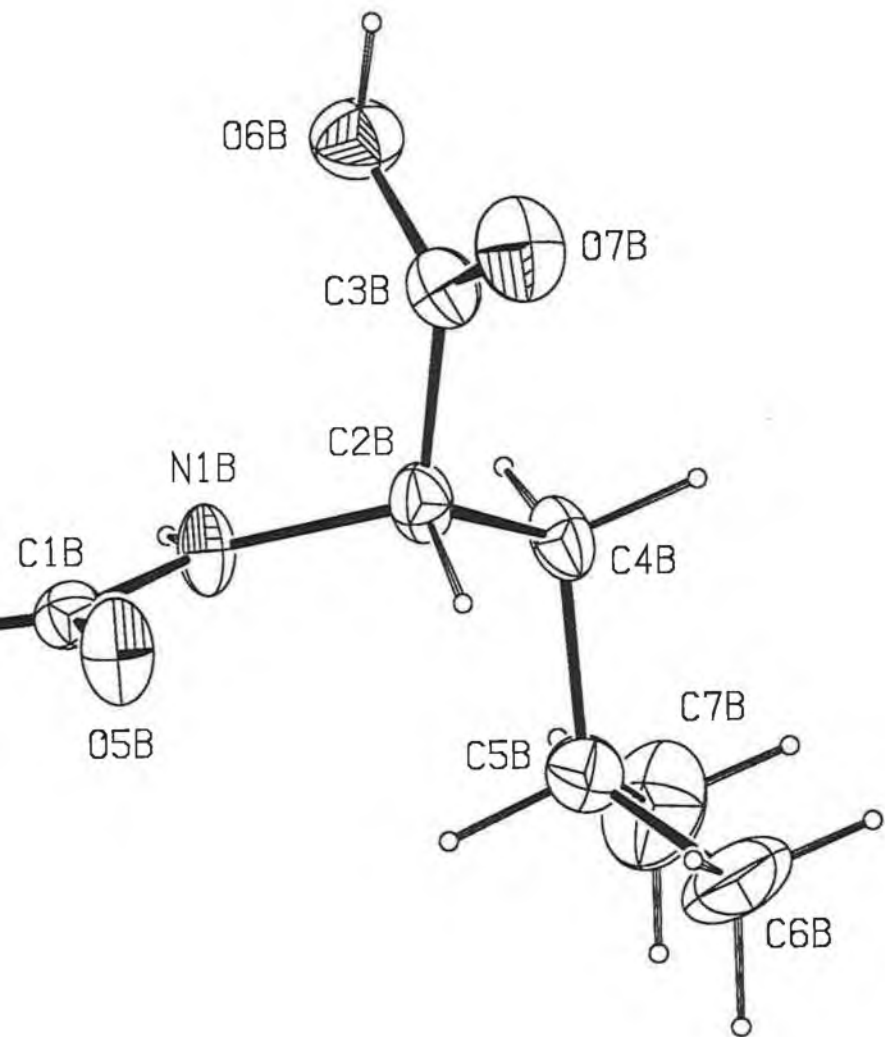

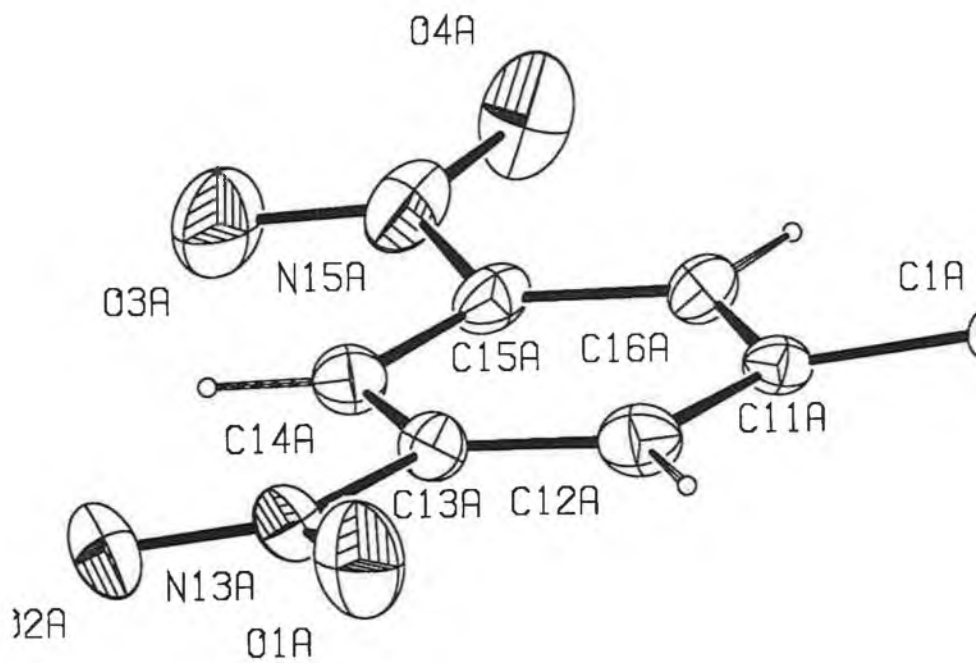

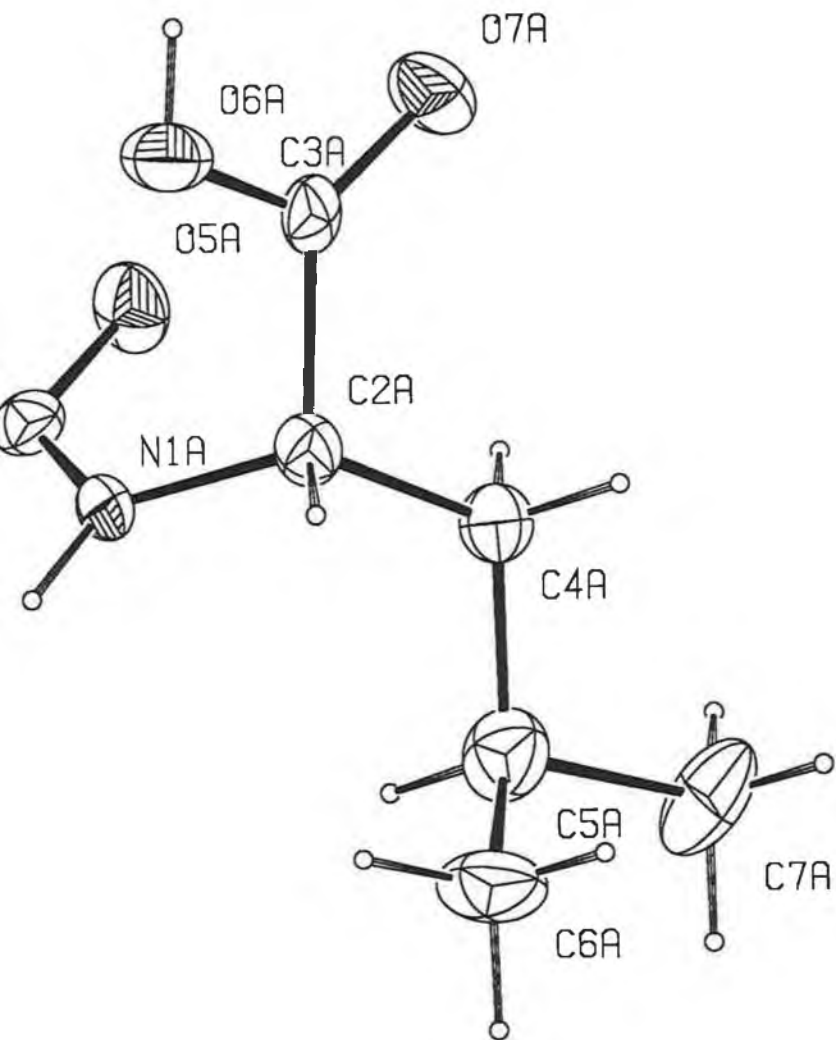

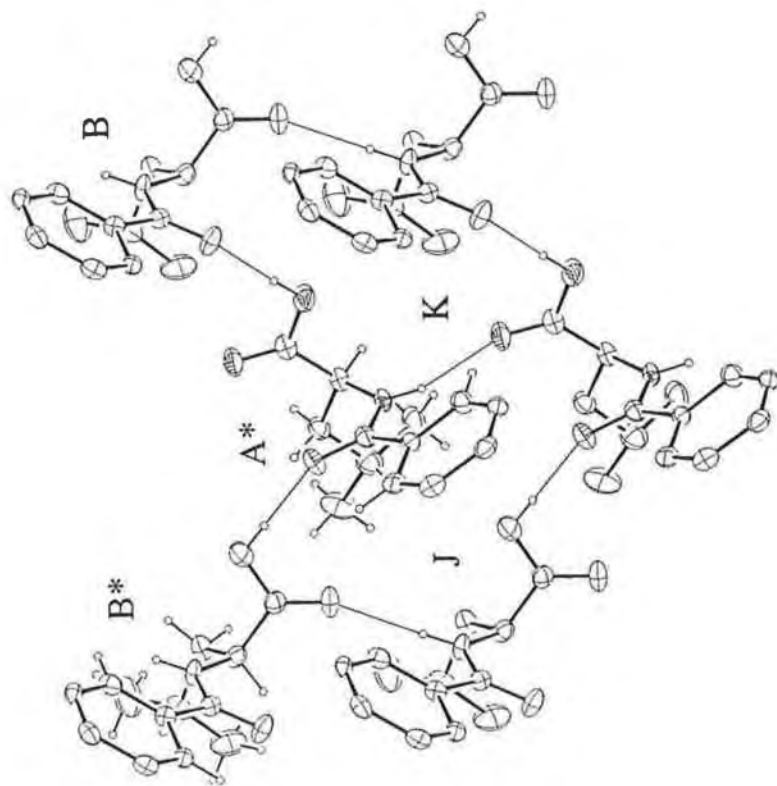

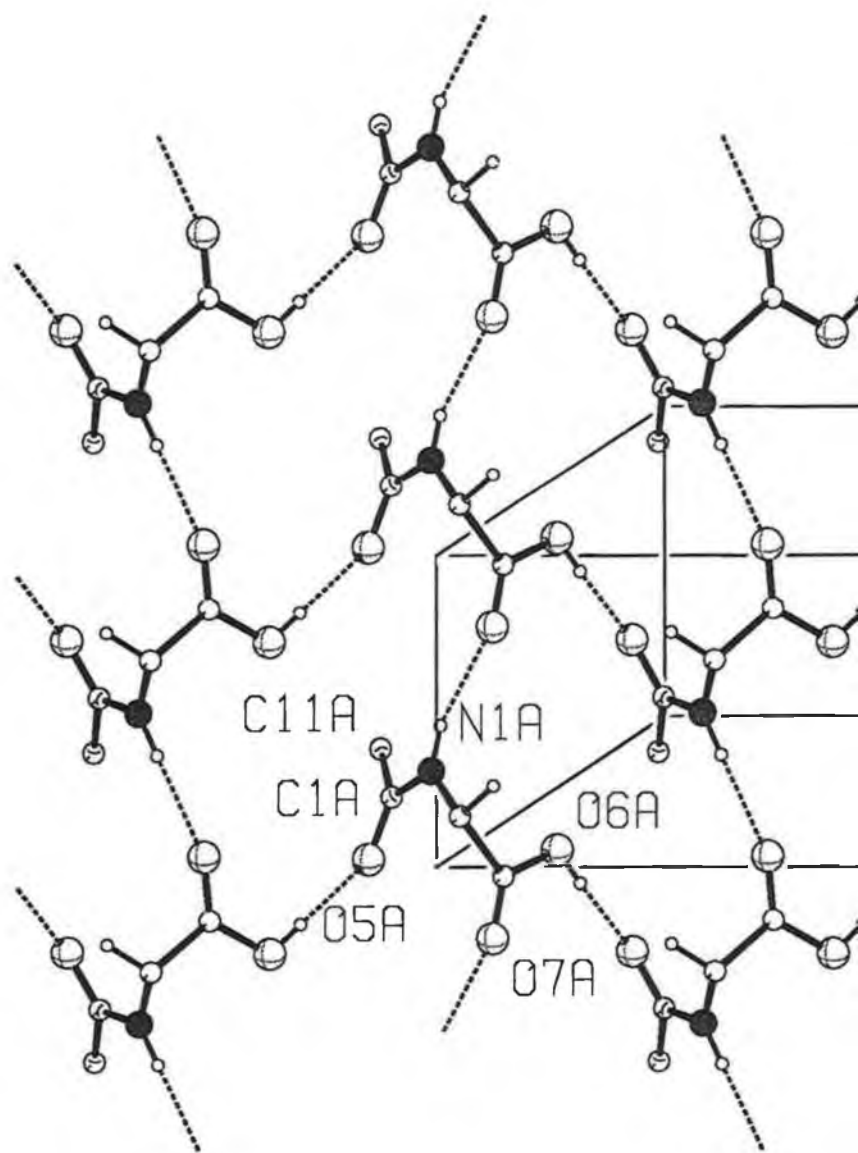

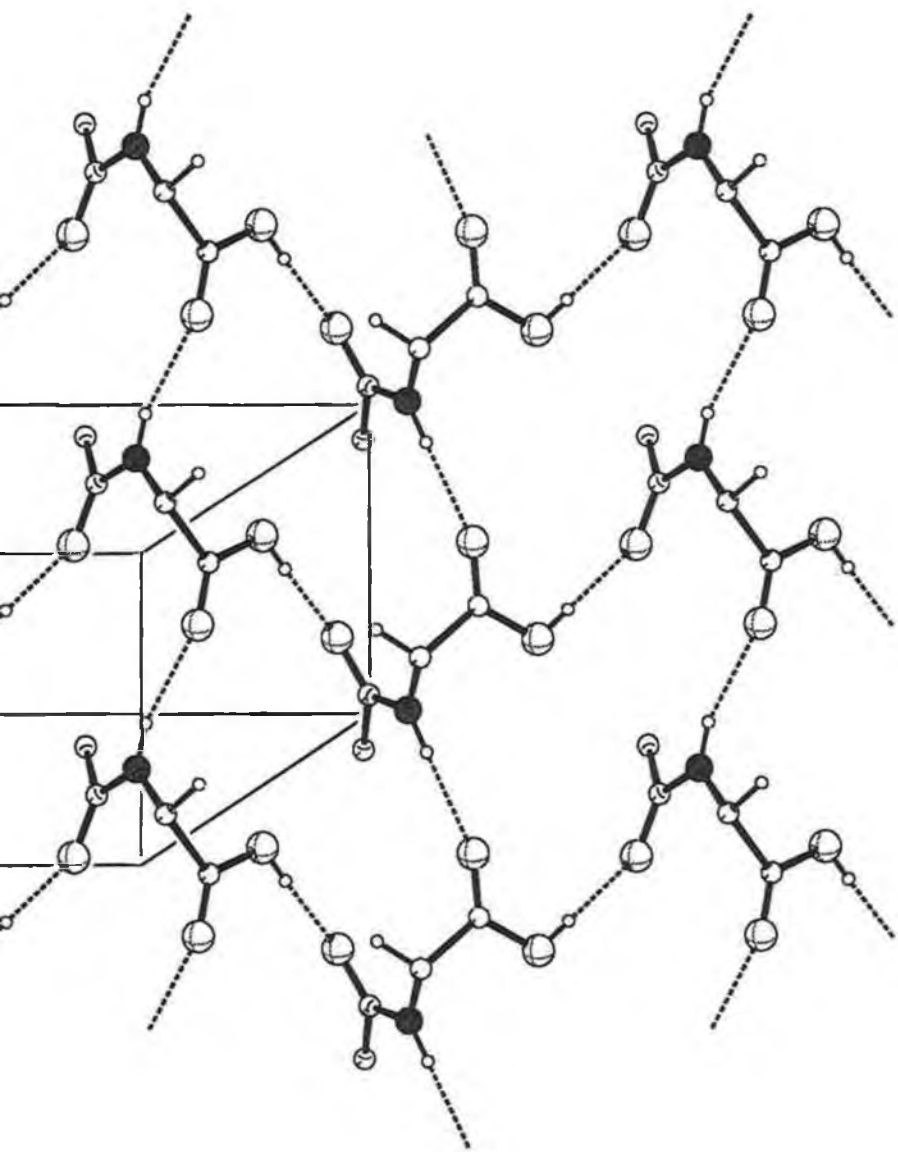

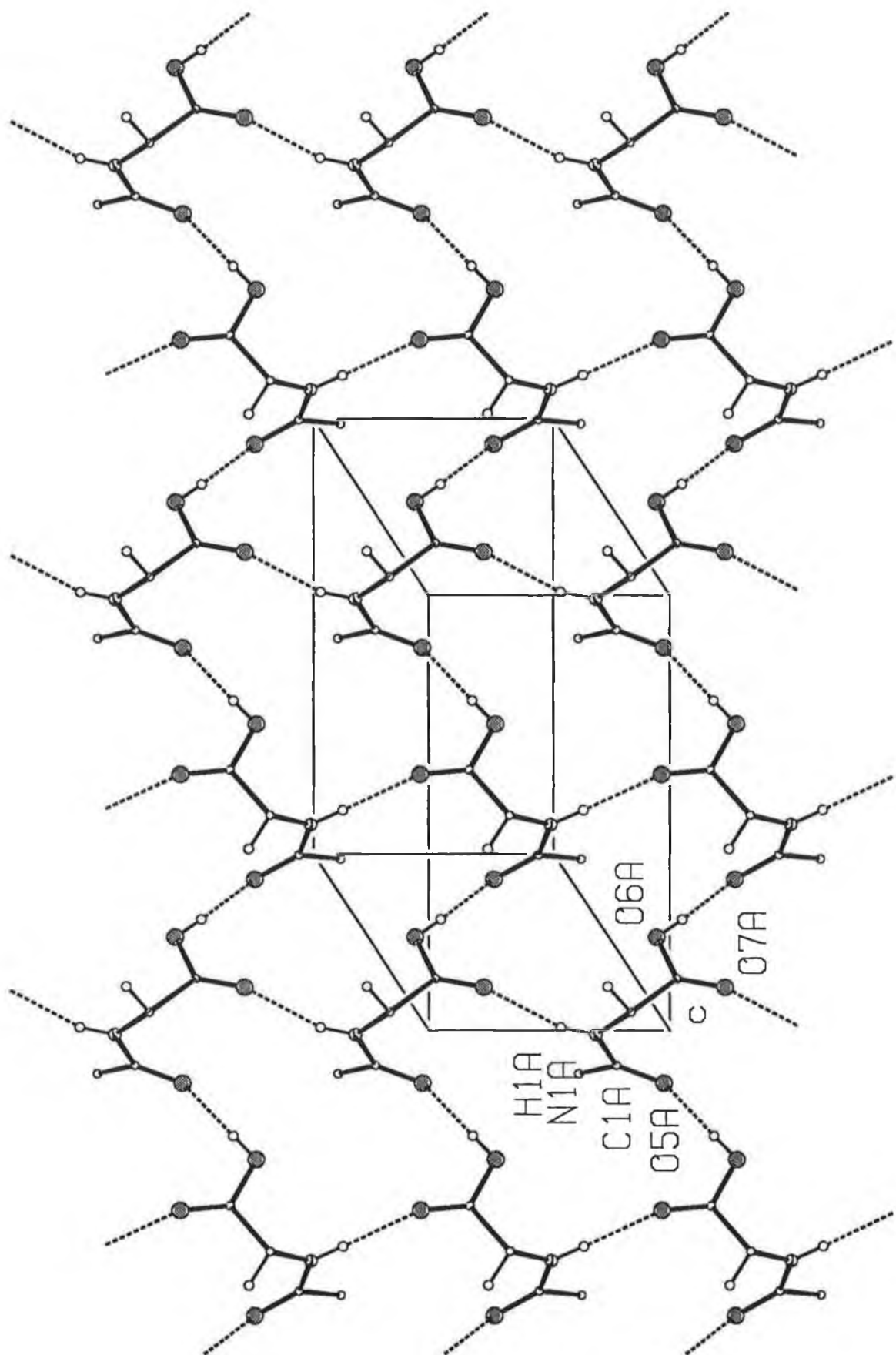

7 Apr 1998

Acta Cryst. (1998). C54, 000-000

N-H···O intramolecular and O-H···O, C-H···O and *sp*³C-H··· π (arene) intermolecular interactions in (2*S*)-2-[(2*R*)-2-hydroxy-2-phenylethanoyl]amino}-4-methylpentanoic acid

JOHN P. DALTON,^a JOHN F. GALLAGHER,^b PETER T. M. KENNY^b AND
MICHAEL O'DONOHUE^b

^a*School of Biological Sciences, Dublin City University, Dublin 9, Ireland,*
and ^b*School of Chemical Sciences, Dublin City University, Dublin 9, Ireland.*
E-mail: gallagherjfg@dcu.i.e

Abstract

The title compound C₁₄H₁₉NO₄ forms a hydrogen-bonded network in the solid state consisting of an intramolecular N—H···O {N···O, 2.569(3) Å} and intermolecular O—H···O=C {O···O, 2.704(2), 2.801(2) Å} hydrogen bonds; C—H···O {C···O, 3.344(3) Å} and *sp*³C—H··· π (arene) {shortest C···C, 3.873(4) Å} interactions.

Comment

The study of biologically active molecules is of primary importance in medicinal chemistry. Processes such as hormone processing, viral replication and cancer cell invasion are critically dependent on protease enzymes which have recently become attractive target molecules in drug design. Many inhibitors are based on modified amino acids which incorporate the basic structural features determining normal enzyme-substrate interactions. The title compound (I), is part of an ongoing study of hydrogen-bonding interactions in amino acid derivatives which may be of relevance towards the design of antimalarial drugs.

A view of molecule (I) (*RS* configuration) with our numbering scheme is given in Fig. 1 and selected dimensions are in Table 2. The bond lengths and angles are in agreement with expected values (Orpen *et al.*, 1994). The phenyl ring is almost perpendicular to the {N1,C2,C3,O3,C4,O4} plane, $86.60(6)^\circ$ and the maximum deviation from planarity for an atom in either plane is $0.172(1) \text{ \AA}$ for C4; the phenyl ring is at an angle of $76.45(9)^\circ$ to the carboxylic acid {O1,O2,C1,C2} plane. Examination of the structure with *PLATON* (Spek, 1997*a*) indicated that there were no solvent accessible voids in the crystal lattice.

Extensive hydrogen bonding is present in the crystal structure consisting of an intramolecular N—H \cdots O and intermolecular O—H \cdots O=C hydrogen bonds, C—H \cdots O and sp^3 C—H \cdots π (arene) interactions; a view is given in Fig. 2 and details are in Table 3. The N \cdots O distance in the intramolecular N—H \cdots O hydrogen bond is $2.569(3) \text{ \AA}$ with N—H \cdots O, $116(2)^\circ$. The O \cdots O intermolecular distances for O1 \cdots O3ⁱ and O4 \cdots O3ⁱⁱ are $2.704(2)$ and $2.801(2) \text{ \AA}$ with O—H \cdots O angles of $170(3)^\circ$ and $168(2)^\circ$ respectively, ($i = 1 - x, y - 1/2, -z$; $ii = 1 - x, y - 1/2, 1 - z$). A weak C—H \cdots O interaction C2—H2 \cdots O2ⁱⁱⁱ with C \cdots Oⁱⁱⁱ, $3.344(3) \text{ \AA}$ and C—H \cdots Oⁱⁱⁱ 159° is also present, ($iii = 1 - x, \frac{1}{2} + y, -z$). A sp^3 C—H \cdots π (arene) interaction with the C8 \cdots Cg1^{iv} distance, $3.873(4) \text{ \AA}$ and C8—H8A \cdots Cg(1)^{iv}, 145° (Cg1 is the ring centroid of the phenyl ring, $iv = 1 + x, y, z$) completes the intermolecular interactions.

The structure of (L)-Leucine has been reported previously, (Harding *et al.*, 1976; Collect *et al.*, 1986; Görbitz & Dalhus, 1996) and contains two crystallographically independent zwitterion molecules having similar conformations in the asymmetric unit.

The presence of C—H \cdots O and C—H \cdots π (arene) interactions with stronger hydrogen bonds *e.g.* O—H \cdots O has been commented on previously (Steiner, 1997). We have recently reported the structure of 2-(1*H*-Imidazol-2-yl)-3,4-dimethyl- 5-phenyl-1,3-oxazolidine (Gallagher *et al.*, 1998) where dominant N—H \cdots N hydrogen bonds are present in the crystal structure with weaker C—H \cdots π (arene), C—H \cdots O and C—H \cdots π (C=C) interactions completing the hydrogen bonding network. The subtle interplay of these intermolecular forces results in the presence of four molecule in the asymmetric unit. In (2R/2S)-2-(1-

oxo-1,3-dihydro-2*H*-isoindol-2-yl)-3-phenylpropanoic acid, the O—H···O hydrogen bonds are present with C—H···O and C—H··· π (arene) intermolecular interactions such that all hydrogen bond donor and acceptors take part in hydrogen bonding (Brady *et al.*, 1998). It is obvious that systematic studies of series of related molecules are necessary for even an elementary understanding of the factors which govern the observed interactions in crystal structures. Further studies are in progress on related amino acid derivatives.

Experimental

25ml of 1M NaOH was added to a solution of N-((R/S)-2-acetoxy-2-phenylacetyl)-L-leucine methyl ester (3.2g, 0.01mol) in CH₃OH (20ml) and allowed to stir at room temperature for 1hr. The solution was cooled to 0° and acidified with 10% HCl; the CH₃OH was removed *in vacuo*. Recrystallisation of the resulting precipitate from acetone/*n*-hexane yielded colourless blocks (2.3g, 87%) suitable for X-ray analysis. m.p. 116–118°C (uncorrected). i.r. ν_{\max} (KBr): 3459 (OH), 3389(NH), 3296, 1725 (carboxylic acid C=O), 1639 (amide C=O), 1556, 1267, 1160cm⁻¹. ¹H NMR data (400 MHz) (δ , DMSO): 0.75–0.85 (12*H*, m, C(CH₃)₂), 1.46–1.66 (6*H*, m, CH₂CH), 4.22–4.28 (2*H*, m, NCHCO₂), 4.93 (2*H*, s, OH), 6.25 (2*H*, s, NCOCH), 7.22–7.40 (10*H*, m, ArH), 7.98–8.00 (2*H*, d, *J* = 8.88Hz, NH). ¹³C NMR data (100 MHz) (δ , DMSO): 173.79, 171.94 (–CO₂H and –C=O), 141.25, 127.89, 127.38, 126.62 (aromatic C atoms), 73.28 (–CHOH), 49.75 (–NHCH), 24.32 (–CH₂), 22.83, 21.36 (CH(CH₃)₂). Note: The signals at 173.79 and 171.94 may be interchangeable. Mass spectrum M–H₂O found: 247.1322, C₁₄H₁₉NO₃ requires 247.1207 m/z (%): 247 (0.5) (M–H₂O), 107 (100), 86 (22), 77 (19).

Crystal data $C_{14}H_{19}NO_4$ $M_r = 265.30$

Monoclinic

 $P2_1$ $a = 8.5887(10) \text{ \AA}$ $b = 8.6404(6) \text{ \AA}$ $c = 9.6169(6) \text{ \AA}$ $\beta = 98.398(7)^\circ$ $V = 706.0(1) \text{ \AA}^3$ $Z = 2$ $D_x = 1.248 \text{ Mg m}^{-3}$ D_m not measuredMo $K\alpha$ radiation $\lambda = 0.7107 \text{ \AA}$ *Data collection*

Enraf-Nonius CAD-4 diffractometer

 ω - 2θ scans

Absorption correction: none

3225 measured reflections

3133 independent reflections

2540 reflections with

 $>2\sigma(I)$ $R_{int} = 0.008$

Cell parameters from 25 reflections

 $\theta = 10.4\text{--}19.7^\circ$ $\mu = 0.091 \text{ mm}^{-1}$ $T = 294(1) \text{ K}$

Block

 $0.38 \times 0.32 \times 0.14 \text{ mm}$

Colourless

Crystal source: synthesized by the
authors, see text $\theta_{max} = 27.4^\circ$ $h = -11 \rightarrow 11$ $k = -11 \rightarrow 11$ $l = 0 \rightarrow 12$

3 standard reflections

frequency: 120 min

intensity decay: no decay, variation

1.0%

*Refinement*Refinement on F^2

$$R[F^2 > 2\sigma(F^2)] = 0.0399$$

$$wR(F^2) = 0.1192$$

$$S = 1.013$$

3133 reflections

184 parameters

mixed

$$w=1/[\sigma^2(F_o^2) + (0.0786P)^2]$$

$$\text{where } P = (F_o^2 + 2F_c^2)/3$$

$$(\Delta/\sigma)_{\max} = 0.000$$

$$\Delta\rho_{\max} = 0.16 \text{ e } \text{\AA}^{-3}$$

$$\Delta\rho_{\min} = -0.15 \text{ e } \text{\AA}^{-3}$$

Extinction correction: *SHELXL97*

Extinction coefficient: 0.037 (8)

Scattering factors from *International**Tables for Crystallography* (Vol. C)

Absolute structure: Flack (1983)

Flack parameter = -1 (1)

Table 1. *Fractional atomic coordinates and equivalent isotropic displacement parameters (\AA^2)*

$$U_{\text{eq}} = (1/3)\sum_i\sum_j U^{ij} a^i a^j \mathbf{a}_i \cdot \mathbf{a}_j.$$

	<i>x</i>	<i>y</i>	<i>z</i>	U_{eq}
O1	0.59948 (19)	0.5082	-0.11799 (16)	0.0428 (4)
O2	0.6090 (3)	0.3478 (3)	0.06460 (18)	0.0603 (5)
O3	0.47750 (17)	0.7702 (2)	0.29740 (14)	0.0357 (3)
O4	0.62859 (17)	0.4387 (3)	0.48594 (16)	0.0405 (4)
N1	0.64033 (19)	0.5759 (3)	0.25073 (16)	0.0302 (4)
C1	0.6194 (2)	0.4751 (3)	0.0168 (2)	0.0332 (4)
C2	0.6649 (2)	0.6160 (3)	0.10900 (18)	0.0285 (4)
C3	0.5450 (2)	0.6452 (3)	0.32722 (18)	0.0277 (4)
C4	0.5127 (2)	0.5566 (3)	0.4572 (2)	0.0310 (4)
C5	0.8373 (2)	0.6567 (3)	0.1013 (2)	0.0369 (5)
C6	0.8983 (3)	0.8023 (4)	0.1799 (3)	0.0468 (6)
C7	0.8209 (4)	0.9465 (4)	0.1149 (4)	0.0743 (9)
C8	1.0762 (3)	0.8109 (5)	0.1859 (4)	0.0754 (10)
C11	0.3466 (2)	0.4924 (3)	0.4289 (2)	0.0339 (4)
C12	0.2312 (3)	0.5483 (4)	0.5024 (3)	0.0499 (6)
C13	0.0789 (3)	0.4889 (4)	0.4754 (3)	0.0639 (8)
C14	0.0437 (3)	0.3732 (4)	0.3802 (3)	0.0621 (8)
C15	0.1573 (3)	0.3148 (4)	0.3067 (3)	0.0594 (7)
C16	0.3088 (3)	0.3757 (3)	0.3308 (2)	0.0440 (5)

Table 2. *Selected geometric parameters (\AA , $^\circ$)*

O1—C1	1.314 (2)	N1—C3	1.322 (2)
O2—C1	1.200 (3)	C1—C2	1.523 (3)
O3—C3	1.239 (2)	C2—C5	1.534 (3)
O4—C4	1.423 (2)	C3—C4	1.525 (2)
N1—C2	1.451 (2)	C4—C11	1.518 (3)

C2—N1—C3	126.97 (18)	N1—C3—C4	115.49 (17)
O1—C1—O2	124.81 (19)	O4—C4—C3	108.22 (15)
O1—C1—C2	112.69 (17)	O4—C4—C11	112.68 (16)
O2—C1—C2	122.44 (18)	C3—C4—C11	108.36 (15)
N1—C2—C1	107.21 (15)	C2—C5—C6	115.51 (17)
N1—C2—C5	111.94 (16)	C5—C6—C7	112.3 (2)
C1—C2—C5	108.83 (15)	C5—C6—C8	109.3 (2)
O3—C3—N1	124.95 (17)	C7—C6—C8	110.8 (2)
O3—C3—C4	119.48 (16)		
C3—N1—C2—C1	-120.0 (2)	O3—C3—C4—O4	-166.9 (2)
C3—N1—C2—C5	120.8 (2)	N1—C3—C4—O4	16.1 (2)
C2—N1—C3—O3	-11.0 (3)	O3—C3—C4—C11	70.7 (2)
C2—N1—C3—C4	165.9 (2)	N1—C3—C4—C11	-106.4 (2)

Table 3. *Hydrogen-bonding geometry* (\AA , $^\circ$)

<i>D—H...A</i>	<i>D—H</i>	<i>H...A</i>	<i>D...A</i>	<i>D—H...A</i>
N1—H11...O4	0.84 (3)	2.09 (2)	2.569 (3)	116 (2)
O1—H1...O3 ⁱ	0.88 (4)	1.84 (4)	2.704 (2)	170 (3)
O4—H41...O3 ⁱⁱ	0.87 (3)	1.95 (3)	2.801 (2)	168 (2)
C2—H2...O2 ⁱⁱⁱ	0.98	2.41	3.344 (3)	159
C8—H8A...Cg1 ^{iv}	0.96	3.01	3.939 (3)	164
C8—H8A...C11 ^{iv}	0.96	3.18	4.104 (4)	161
C8—H8A...C12 ^{iv}	0.96	3.05	3.873 (4)	145
C8—H8A...C13 ^{iv}	0.96	3.16	3.934 (5)	139
C8—H8A...C14 ^{iv}	0.96	3.43	4.246 (4)	144
C8—H8A...C15 ^{iv}	0.96	3.57	4.470 (5)	157
C8—H8A...C16 ^{iv}	0.96	3.44	4.389 (4)	172

Symmetry codes: (i) $1 - x, y - \frac{1}{2}, -z$; (ii) $1 - x, y - \frac{1}{2}, 1 - z$; (iii) $1 - x, \frac{1}{2} + y, -z$; (iv) $1 + x, y, z$.

Molecule (I) which is chiral, crystallised as *RS* and *SS* diastereomers in the solid state. A crystal with *RS* configuration at the chiral centres was chosen for examination; space group $P2_1$ from the systematic absences.

A full "Friedel" data set was collected for this structure although the anomalous dispersion terms for O, N and C are small. The absolute structure was not determined (Flack parameter, $-1(1)$) by our X-ray analysis but can be inferred from the known absolute configuration of the starting material used in the synthesis.

The H atoms attached to carbon were treated as riding atoms with the C—H bond lengths in the range 0.93 to 0.98 Å; the N—H and O—H distances were refined to 0.837 (28) Å, 0.876 (38) Å and 0.867 (29) Å respectively.

Data collection: CAD-4 (Enraf-Nonius, 1992). Cell refinement: *SET4* & *CELDIM* (Enraf-Nonius, 1992). Data reduction: *DATRD2* in *NRCVAX96* (Gabe, Le Page, Charland, Lee & White, 1989). Program(s) used to solve structure: *SHELXS97* (Sheldrick, 1997). Program(s) used to refine structure: *NRCVAX96* and *SHELXL97* (Sheldrick, 1997). Molecular graphics: *NRCVAX96*, *ORTEP* (Johnson, 1976), *PLATON* (Spek, 1997*a*), *PLUTON* (Spek, 1997*b*). Software used to prepare material for publication: *NRCVAX96*, *SHELXL97* and *WordPerfect* macro *PRPCIF97* (Ferguson, 1997).

P. K. and M. O.'D thank the School of Chemical Sciences for financial support. J. F. G. thanks the Research and Postgraduate Committee of Dublin City University, the Royal Irish Academy and Forbairt for generous funding of a research visit to the University of Guelph (June–August, 1997) and especially Professor George Ferguson for use of his diffractometer and computer system.

Supplementary data for this paper are available from the IUCr electronic archives (Reference: PRINTCIF). Services for accessing these data are described at the back of the journal.

References

- Brady, F., Gallagher, J. F. & Kenny P. T. M. (1998). *Acta Cryst.* C54, In the press, [CF1250].
- Collect, M., Solans, X., Font-Altaba, M. & Subirana, J. A. (1986). *Acta Cryst.* C42, 599–601.
- Enraf-Nonius (1992). CAD-4-PC Software, Version 1.1. Enraf-Nonius, Delft, Holland.
- Ferguson, G. (1997). PRPCIF97 - a *WordPerfect*-5.1 macro to merge and polish CIF format files from *NRCVAX* and *SHELXL97* programs. University of Guelph, Canada.
- Flack, H. D. (1983). *Acta Cryst.* A39, 876–881.
- Gabe, E. J., Le Page, Y., Charland, J.-P., Lee, F. L. & White, P. S. (1989). *J. Appl. Cryst.* 22, 384–387.
- Gallagher, J. F., Briody, J. M. & Cantwell, B. P. (1998). *Acta Cryst.* C54, In the press, [SK1179].
- Görbitz, C. H. & Dalhus, B. (1996). *Acta Cryst.* C52, 1754–1756.
- Harding, M. M. & Howieson, R. M. (1976). *Acta Cryst.* B32, 633–634.
- Johnson, C. K. (1976). *ORTEP* - A Fortran Thermal Ellipsoid Plot Program, Technical Report ORNL-5138, Oak Ridge National Laboratory, USA.
- Orpen, A. G., Brammer, L., Allen, F. H., Kennard, O., Watson, D. G. & Taylor, R. (1994). In Appendix A of *Structure Correlation*, Vol. 2. Editors. H.-B. Bürgi and J. D. Dunitz, VCH *Publ.* Weinheim, Germany.
- Sheldrick, G. M. (1997). *SHELXS97*. Program for the solution of crystal structures. University of Göttingen, Germany.
- Sheldrick, G. M. (1997). *SHELXL97*. Program for the refinement of crystal structures. University of Göttingen, Germany.
- Spek, A. L. (1997*a*). *PLATON* Molecular Geometry Program, version of May 1997.

University of Utrecht, Utrecht, Holland.

Spek, A. L. (1997*b*). *PLUTON* Molecular Graphics Program, version of May 1997.

University of Utrecht, Utrecht, Holland.

Steiner, T. (1997). *J. Chem. Soc. Chem. Commun.* pp. 727–734.

Fig. 1. A view of (I) with our numbering scheme. Displacement ellipsoids are drawn at the 30% probability level.

Fig. 2. A view of the hydrogen bonding in the crystal structure.

Table 1. Fractional atomic coordinates and equivalent isotropic displacement parameters (\AA^2) for compound (I)

Table 2. Selected geometric parameters (\AA , $^\circ$) for compound (I)

Table 3. Hydrogen bond parameters (\AA , $^\circ$) for compound (I)

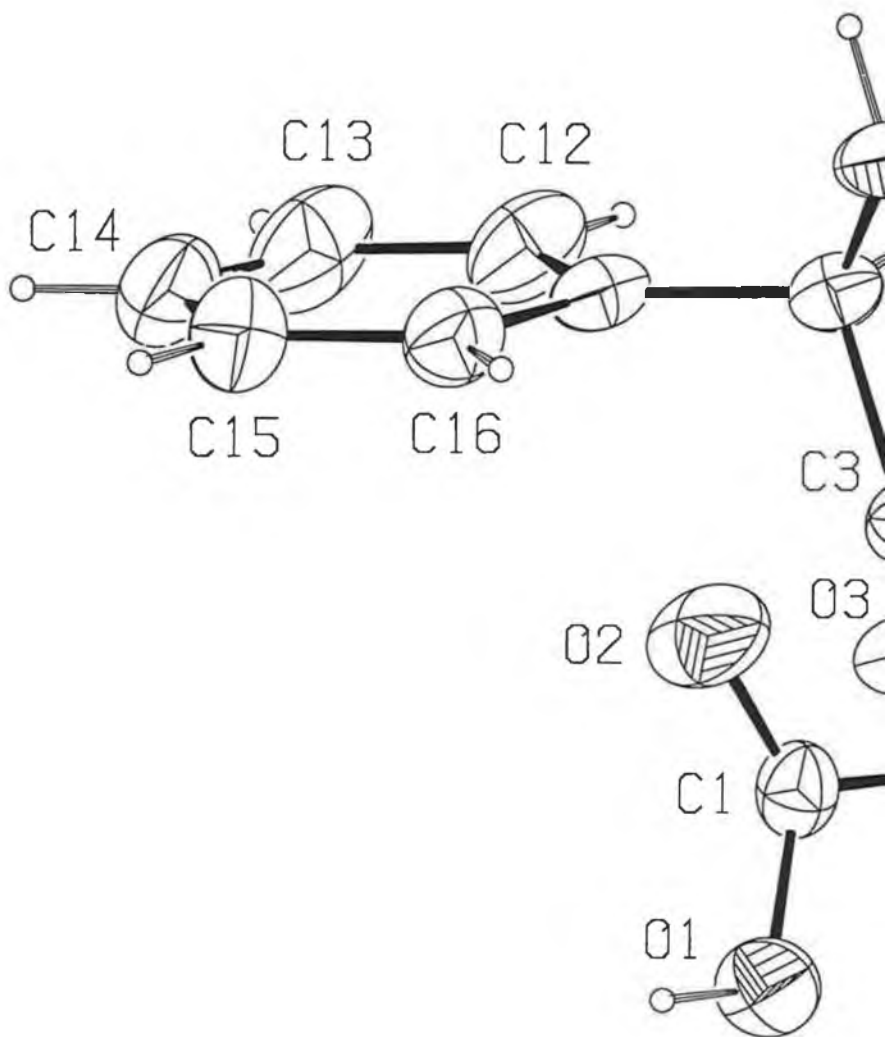

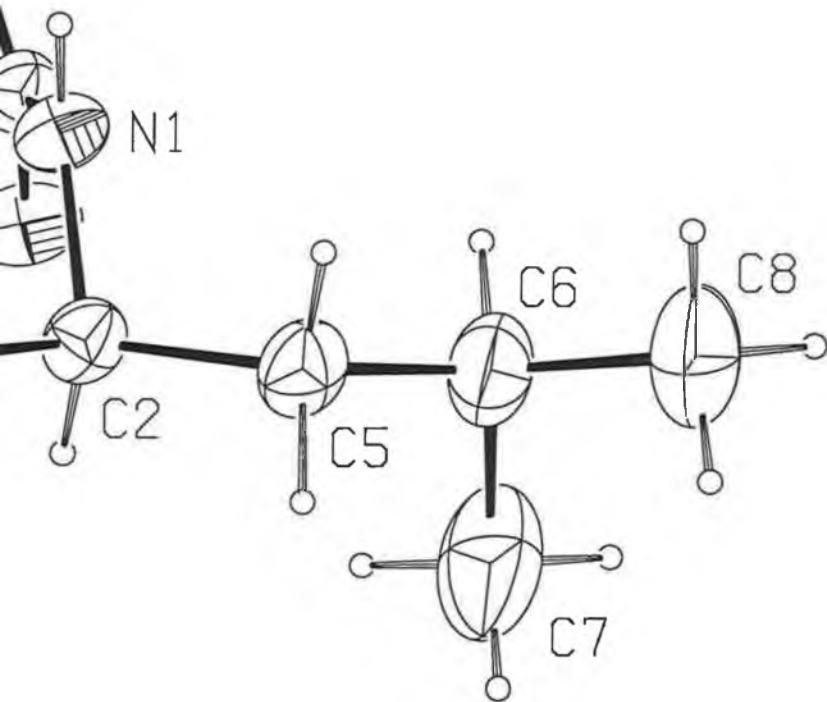
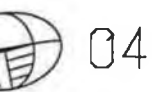

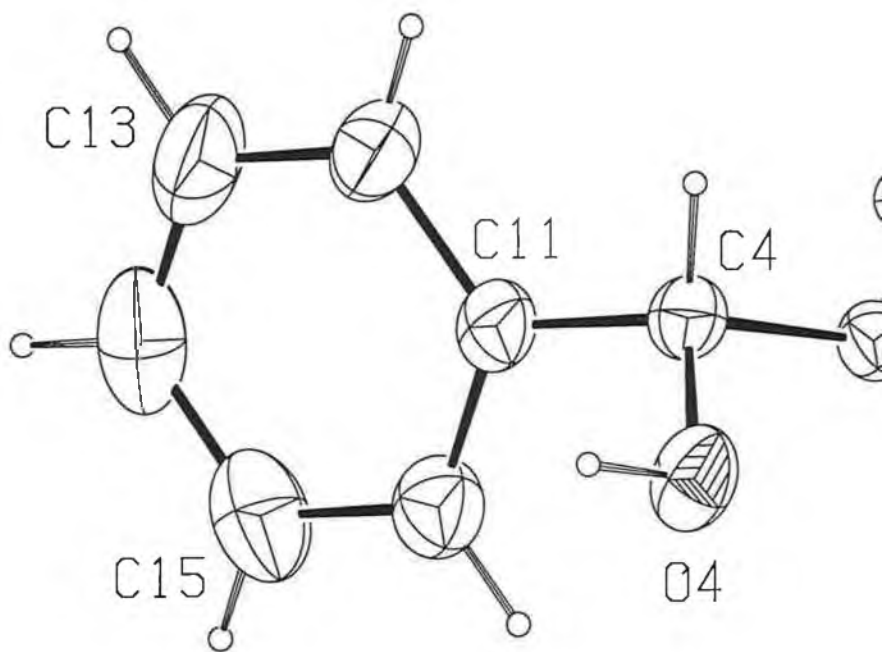

Partial ORTEP diagram showing the thermal ellipsoid for atom O2. The ellipsoid is drawn at the 50% probability level.

