

# Photochromic spiropyran monolithic polymers: Molecular photo-controllable electroosmotic pumps for micro-fluidic devices

Zarah Walsh,<sup>a</sup> Silvia Scarmagnani,<sup>b</sup> Fernando Benito-López<sup>b</sup>, Silvija Abele<sup>a,1</sup>, Fu-Qiang Nie<sup>a,2</sup>, Conor Slater<sup>b</sup>, Robert Byrne<sup>b</sup>, Dermot Diamond<sup>b</sup>, Brett Paull<sup>a</sup>, Mirek Macka<sup>a,\*</sup>

## Abstract

A novel photo-controllable micro-fluidic electroosmotic pump based on spiropyran monolithic polymers is presented here for the first time. Photochromic monolithic scaffolds have been synthesised within poly(tetrafluoroethylene) coated fused silica capillaries. These monoliths have a photochromic spiropyran monomer incorporated in the bulk by thermally induced copolymerisation with a cross-linking agent (divinylbenzene) and were encased in micro-fluidic devices to function as photo-controllable electroosmotic pumps (EOPs). Due to the presence of the spiropyran the monolith can exist in two forms: a zwitterionic merocyanine (MC) form and an uncharged spiropyran (SP). As both forms bare a net overall zero charge, an acidic electrolyte was used to produce a stable anodic electroosmotic flow (EOF), while still retaining the ability to switch between the SP and the MC forms, which exhibit different charge distributions. It was confirmed that visible light, which produces the SP form, caused an increase in EOF while UV light, which generates the MC form, caused a decrease in EOF. In this way the EOF from the chip was modified by light and not by changing the electric field, temperature or buffer pH, some of the more common methods of altering the EOF.

## Keywords

Photo-switchable electroosmotic flow; Photochromic monolith; Electroosmotic pump; Micro-fluidics; Spiropyran

## 1. Introduction

Chromatography is now over 100 years old [1–4] but the single most important advance in the field since the inception of chromatography was only developed in the early 1990s: the monolithic stationary phase, acknowledged as the “the first original breakthrough to have occurred in this area since Tswett invented chromatography, a century ago” [5]. Monoliths are valued for their relatively low resistance to pressure driven flow and the ability to prepare them in situ in capillaries and micro-fluidic chips by thermally and photo-initiated polymerisations [6–8]. Monoliths have found many applications outside of the area of separations science and chromatography, including as actuators [9–11]. In these works the monoliths were externally actuated by temperature, while other external stimuli have not been reported. Here, in this work, we report for the first time a light-responsive (photochromic) monolith externally actuated with UV- and

visible light. This is achieved by incorporating into the porous organic monolith a photochromic dye from the spiropyran family that changes its structure and charge distribution with light.

The spiroyrans were first discovered in 1921 [12] but their best studied property, their photochromism, was not observed until 1952 by Fischer and Hirshberg [13]. They are a well known family of dyes, which in addition to photochromism, also display thermochromic [12], solvatochromic [14], acidochromic [15] and electrochromic [16] behaviour. The dyes exist in two main forms: an uncharged, colourless spiropyran (SP) and an intensely coloured, zwitterionic merocyanine (MC). The structure of the two forms of the dye is shown in Fig. 1.

The conversion between the SP and the MC form is carried out with ultraviolet (UV) and visible light. Irradiation of the molecule with UV light at approximately 375 nm produces the zwitterion, while the white light returns the molecule to the uncharged form. The  $\lambda_{\text{max}}$  of absorbance of the spiropyran in the visible region is approximately 540 nm (depending on the specific derivative of the molecule), however, it was found through the course of this research that white light instead of green light produces a faster reconversion to the SP form [20]. This switching process is entirely reversible over a large number of irradiations although the exact number depends on several factors such as the stability of the particular spiropyran, the intensity of the light source and the presence of oxygen as the dye is susceptible to photo-bleaching, irreversible cleavage of the pyran ring [12]. It was found that the period of time over which the molecule is stable can be increased by binding it to, or incorporating it within, some type of polymeric support rather than leaving it free in solution [21]. This is likely due to the fact that, when immobilised, the chances of aggregation of the molecule in solution are reduced and so the dye switches more freely [22]. There is a minimum distance to be observed between the spiropyran and the support in order to prevent the surface interactions from interfering with the switching efficiency [20]. In previous work, it has been shown that a chain length of 8-methylene groups provides enough separation from the surface to allow effective switching between the two forms of the molecule [20]. Conversion experiments conducted with light emitting diodes (LEDs), chosen for their high intensity, quasi-monochromatic light output and negligible heat generation [23,24], showed that more than 100 switches could be performed when the spiropyran was immobilised on polymeric beads before a decrease in the switching intensity could be detected [20]. Moreover, spiropyran moieties have recently been immobilised by us in polydimethylsiloxane (PDMS) micro-fluidic channels as a photonically controlled, self-indicating system for metal ion accumulation and release [25].

In this work a spiropyran derivative with a long vinyl chain, 1',(9-decenyl)-3',3'-dimethyl-6-nitrospiro-[2H-1]-benzopyran-2,2'-indoline, synthesised from a procedure by McCoy *et al.* [26] was incorporated into a polymeric monolith by copolymerising it with a common cross-linker, divinylbenzene, to produce a

rigid, macro-porous, photochromic monolith. The monolithic stationary phase was then characterised, incorporated in the channel of a micro-fluidic chip and applied as an electroosmotic pump with photo-controllable flow rates. This novel pumping system described in detail below provides the ability to modify the flow rate not only by changing the electric field, as is commonly done [27], but also by irradiation with light. To our best knowledge, this is the first example of a photo-controllable electroosmotic pumping system and the first example of an externally photo-actuated porous monolith with its properties changing reversibly and repeatedly with irradiation by UV- and visible light. The most commonly exploited property of these molecules is their photochromism, which has allowed them to find applications in light sensitive media such as photo-sensitive ophthalmic lenses and optical recording media [17–19]. This photochromism, that is the conformational and polarity changes induced by light irradiation, is at the core of this work exploring the possibility of creating a photochromic monolithic porous material for a multitude of uses in separation science and elsewhere, with the specific attention to the development of a photo-dynamically controllable electroosmotic pumping system.

## **2. Experimental**

### **2.1. Reagents**

2,3,3-Trimethylindoline, 2,2-azobisisobutyronitrile (AIBN), 3-(trimethoxysilyl)propyl methacrylate (TMSPM), acetone, 1-decanol, divinylbenzene (DVB), ethanol, hydrochloric acid, 10-bromo-1-decene, 5-nitrosalicylaldehyde, methanol and styrene were all purchased from Sigma–Aldrich Chemical Co. (Dublin, Ireland) and all chemicals were used as received.

### **2.2. Materials**

100 µm i.d. poly(tetrafluoroethylene) (PTFE) coated fused silica capillary was purchased from Polymicro Technologies (Phoenix, AZ, USA).

5 min epoxy resin was purchased from Bondloc (Worcestershire, UK). Pressure sensitive adhesive (PSA, ARcare 8890) and sheets of poly(methyl methacrylate) (PMMA) were purchased from Adhesives Research Ltd. (Limerick, Ireland).

400 µm i.d. poly(ether ether ketone) (PEEK) tubing and a nano-flow sensor to monitor eluent flow rate from the electroosmotic pump was obtained from Upchurch Scientific (Oak Harbor, WA, USA).

375 nm and white (400–750 nm) LEDs were purchased from Roithner Laser Technik (Vienna, Austria). Standard stabilised power supplies (Maplin Electronics, Rotherham, UK), operated in constant current mode, were used to power the LEDs.

High voltage was generated for the EOP using a 0–30 kV high voltage power supply from Unimicro Technologies (Pleasanton, CA, USA).

## **2.3. Procedures**

### ***2.3.1. Pre-treatment of the PTFE-coated fused silica capillaries***

The capillary was treated before polymerisation in order to ensure good wall attachment using a procedure described by Okanda and El Rassi [28]. In brief, the capillaries were flushed with 1 M NaOH for 30 min, followed by 0.1 M HCl for 30 min and finally deionised water for a further 30 min. The capillaries were then flushed with acetone and dried with by flushing with air for 30 min. In the mean time a solution containing 50% TMSPM in acetone was prepared, sonicated and purged. This was then introduced into the dry capillaries used a peristaltic pump. The capillaries were sealed with rubber septa and immersed in a water bath at 60 °C for 20 h. After treatment the capillaries were flushed with methanol to remove all traces of the silanising agent and dried under nitrogen flow.

### ***2.3.2. Synthesis of the SP monomer***

A monomeric spiropyran, 1',(9-decenyl)-3',3'-dimethyl-6-nitrospiro[2H-1]-benzopyran-2,2'-(2H)-indoline, containing a long carbon chain with a vinyl group on the indoline ring, Fig. 1, which is suitable for subsequent copolymerisation with a divinylbenzene monomer, was synthesised in a two-step procedure. Firstly, an N-alkylation of the 2,3,3-trimethylindoline with a 10-bromo-1-decene is carried out followed by a coupling with 5-nitrosalicylaldehyde as outlined in a procedure by McCoy *et al.* [26], as shown in Fig. 2. The reaction is carried out at 80 °C in basic media, it is important that the temperature is not exceeded as this can induce polymerisation of the product.

### ***2.3.3. Synthesis of poly(spiropyran-co-divinylbenzene)***

A 110 µl pre-polymer solution, in which the monomers constitute 40% of the total volume, was prepared containing 40 µl divinylbenzene, 6 mg of the spiropyran monomer, 70 µl of 1-decanol and 0.42 mg of AIBN. The solution was then sonicated, purged with nitrogen and then filled by capillary action into pre-treated PTFE-coated fused silica capillaries. Sealing with a rubber septum attached to a weight, the capillaries were immersed in the water bath vertically in order to promote a more homogeneous and dense growth of polymer. The polymer was allowed to form over 5 days at 60 °C. After polymerisation the columns were flushed with methanol for 30 min to remove porogens and unreacted initiator.

### ***2.3.4. Synthesis of poly(styrene-co-divinylbenzene)***

A 200 µl pre-polymer solution, in which the monomers also constitute 40% of the total volume, was prepared containing 40 µl styrene, 40 µl divinylbenzene, 120 µl 1-decanol and 0.73 mg of AIBN. The solution was sonicated, purged with nitrogen and then filled by capillary action into pre-silanised PTFE-

coated fused silica capillaries as before. They were then polymerised in the same way as the poly(spiropyran-co-divinylbenzene) monoliths described previously with the exception that the polymerisation time was 20 h.

### **2.3.5. Fabrication of the micro-fluidic chip platform**

In order to provide support for the short lengths of capillary functioning as electroosmotic pumps, a micro-fluidic device was designed and fabricated. Channels in the micro-fluidic chip were first designed using 3D Excalibur software (Progressive Software Corp., USA) and then fabricated by direct micro-milling (Datron 3D M6, Datron Technology Ltd., Milton Keynes, UK). A chip 20 mm × 30 mm × 5 mm with channels 8 mm × 0.4 mm × 0.4 mm was produced as described by Nie *et al.* [29,30]. The PMMA sheets were washed thoroughly with ethanol after milling to remove traces of dust and excess PMMA and capillaries within which the photochromic monoliths were contained were encased in the channels. In order to compare the response of a non-switchable monolith with the photochromic monoliths, a poly(styrene-co-divinylbenzene) monolith was synthesised and encased in one of the channels of the chip. The capillaries were held in place in the channel using a drop of 5 min epoxy glue before the channels were covered with a layer of PSA and a second, unmilled sheet of PMMA. The whole chip was placed in a vice for several minutes to ensure that the chip was well sealed and would not leak. 1 cm lengths of PEEK tubing were used as inlet and outlet tubing and were connected from the inlet/outlet to 1.5 ml Eppendorf tubes, which served as solvent reservoirs (Fig. 3). The chip design allowed easy inlet/outlet capabilities for the capillaries, support for the capillaries and easy access to buffer reservoirs.

### **2.3.6. Characterisation of the monoliths**

Before any electroosmotic pumping experiments were attempted it was necessary to characterise the monolithic stationary phase and the presence of the spiropyran. The monolith itself was characterised by optical and scanning electron microscopy.

A SVM-340 Synchronised Video Microscope (Labsmith, USA) was used for the former while an S-3000N VP-SEM (Hitachi, Japan) was used for the latter.

The presence of the spiropyran was verified by reflective absorbance spectroscopy for which a purposely designed capillary holder for reflectance measurement was fabricated in black acrylonitrile-butadiene-styrene (ABS) copolymer with a Stratasys 3D printer (Eden Prairie, MN, USA). The two parts of the holder (the probe case and the capillary case) were designed using a standard CAD/CAM software package (ProEngineer from PTC, Needham, MA, USA) [31]. Reflectance UV-Vis spectra were recorded using a S2000® spectrometer combined with a FCR-7UV200-2 reflection probe (7 μm × 200 μm cores), which was connected to a DH-2000-FSH, deuterium (215–400 nm) and halogen (400–1700 nm) light source, using a PTFE based reflectance standard WS-1-SL to standardise measurements at 100%

reflectance [32,33]. All spectrometric instrumentation was purchased from Ocean Optics Inc. (Eerbeek, Netherlands). The resulting spectra are relative measurements processed by the Ocean Optics software against the previously recorded reference spectrum, which was recorded in the dark at the same distance from the probe as the sample [32–34].

### ***2.3.7. Measurement of the electroosmotic flow (EOF)***

The channels and reservoirs of the electroosmotic pump were filled with 1 mM HCl, specifically chosen to protonate the spiropyran and generate charge on the SP form and a stable positive charge on the MC form of the molecule. The electrodes were immersed in the electrolyte, a field from 0 to 125 kV/m was applied across the channels and finally the flow rate of the eluent from the channel was measured using a nano-flow sensor. All the experiments were carried out in the dark with the outlet tubing positioned at the same height as the reservoirs so that there was no difference in pressure between the outlet and the inlet. The EOF was measured when the monolith was switched by LED to each of the two forms of the spiropyran.

## **3. Results and discussion**

The strategy chosen in this work to create an externally actuated light-switchable porous material was to copolymerise a spiropyran derivative carrying a double bond, here called the “spiropyran monomer”, into an organic porous monolith. Organic porous monoliths were introduced by Svec and Fréchet [6] and became hugely successful and popular as continuous separation media for chromatography. Incorporation of a photochromic molecule into an organic monolith in a way that does not disable the switching is extremely useful for the creation of photochromic monoliths for Separation science and potentially numerous other applications. Creating a photochromic monolith and demonstrating a photocontrollable electroosmotic flow was a novel outcome of this work.

Synthesis of the spiropyran monomer was quite straightforward and was carried out exactly as described in the publication of McCoy et al. [26]. For the synthesis of the spiropyran monolith both ethylene dimethacrylate and divinylbenzene were used as cross-linkers, however only divinylbenzene produced a rigid macro-porous copolymer with the spiropyran monomer. Once divinylbenzene was selected three different concentrations of spiropyran were added to the polymerisation solution (4%, 10% and 50%, w/v, of total solution) but it was found that only the lowest concentration (4%, w/v) would dissolve in the mixture, therefore all polymerizations were carried out with the stock solution containing this concentration of spiropyran relative to the divinylbenzene cross-linker. The solubility of the spiropyran monomer could be increased by using short-chain alcohols as porogens, e.g. ethanol; however this is known to result in a large decrease in the permeability of the monolith. It was desirable in this case to have monolithic materials, which could be easily flushed, and therefore decanol remained as the porogen.

As this is the first reported synthesis of poly(spiropyran-co-divinylbenzene) monoliths it is important to confirm from SEM images the polymer has the same characteristic, globular, porous structure of polymer monoliths (Fig. 4) often shown in the literature [35]. Importantly it can be seen that the polymer is well attached to the walls of the capillary providing good mechanical stability, which is important for successful chromatographic and electrophoretic applications [36].

Once the poly(SP-co-DVB) monoliths were synthesised it was necessary to characterise them to show that the spiropyran was present and switching effectively before the monoliths could be applied as electroosmotic pumps. Optical microscopy was used to verify the filling of the capillary as well as to get a closer look at the colour change of the monolith when irradiated with different wavelengths of light. Fig. 5a shows the capillary after 2 min of irradiation with a white LED when the monolith was dry. It is clear from the image that the monolith is well filled with no apparent voids in the polymer and that there is no colour in the monolith due to the presence of the SP form. Fig. 5b shows the same monolith after 2 min irradiation at 375 nm. Here the monolith appears blue showing the presence of the MC form of the dye. The colour change not only proves the presence of the spiropyran and its ability to switch but it also indicates that the spiropyran is copolymerised with the divinylbenzene and not simply immobilised on the surface. This confirmation is based on the above mentioned solvatochromic behaviour of the spiropyrans, which means that in a polar environment the MC form will appear pink while in a non-polar environment there will be an hypsochromic shift in absorbance and the MC form will appear blue [37]. As the monolith is dry there is no solvent present to influence the colour change and so the colour is dictated by the polarity of the matrix, which in this case is divinylbenzene, a highly non-polar matrix. This has also been noted by Zhu et al. [38]. The presence of the blue colour indicates that the copolymerisation has been successful as in preliminary experiments (data not shown here) the MC form grafted onto the surface of a non-polar monolith in the dry form appears pink. It is believed that by copolymerisation, therefore incorporation in the bulk, the spiropyran is more closely affected by the non-polar matrix and so undergoes a solvatochromic response causing it to appear blue.

Reflective absorbance spectroscopy (RAS) was also carried out on the monolithic stationary phase within the capillary to confirm the switching between the SP and MC forms in both the non-polar form and in a polar solvent (Fig. 6). When the column is irradiated with the 375 nm LED a band appears in the spectrum at the max of absorbance of the dye in the visible region indicating the presence of the MC form of the monolith (green and red lines, Fig. 6). To achieve a more intense signal from the MC form of the monolith during this measurement the column was flushed with ethanol, this causes an hypsochromic shift in the wavelength of absorbance of the MC form. To summarise, in the non-polar matrix the  $\lambda_{\text{max}}$  of the MC is 582 nm (green line) while in the polar solvent it is approximately 550 nm (red line). The MC band disappears when the column is irradiated with white light showing that the polymer can be reconverted to

the SP form (blue and black lines, Fig. 6). In the presence of the 1 mM HCl used in the following experiments the protonated merocyanine form appears yellow in colour with an absorbance band in the region 410–430 nm [39]. As the colour change between the white SP and the yellow MC<sup>+</sup> is negligible it is not shown in Fig. 6. The time necessary for the conversion of the SP to the MC form was determined by a simple kinetics experiment, which was carried out by putting the capillary in the in-house made probe holder, irradiating the capillary at 375 nm for 5 min and taking a spectrum every 10 s to monitor the conversion of the SP form. It was observed that this conversion took approximately 120 s. According to the literature the conversion of the SP to MC in solution is rather quick; however, in the presence of macrocycles this conversion is hindered and slowed down [40]. In this case due to the fact that the spiropyran is encompassed in the bulk polymer and not free in solution or immobilised as a thin layer on a polymer surface, a slow conversion such as that observed is to be expected. This information is important to be able to effectively control the photo-controllable electroosmotic pump.

After characterisation of the monolithic capillaries 8 mm lengths were cut and encased in a PMMA micro-fluidic chip as outlined in the experimental section (Fig. 3). The encasement procedure was necessary due to the fragility of the PTFE-coated capillary in which the monolith had been synthesised. In previous experiments manipulation of the capillary, i.e. flushing, threading into reservoir vials, etc., had caused stripping of the PTFE from the fused silica and breakage of the entire capillary. For these reasons the micro-fluidic platform was designed and assembled, providing support for the capillary and easy connection of the capillary, reservoirs and high voltage (HV) power supply. The channels and reservoirs were filled with 1 mM HCl as the electrolyte and then exposed to alternating irradiation with UV and visible light causing the spiropyran monolith to switch its configuration as shown in Fig. 1.

It was observed that the protonated SP-form produced an increase in the EOF while the protonated MC form caused a relative decrease in the EOF, this can be seen in Fig. 7. As the SP form of the monolith has no surface charge before flushing with 1 mM HCl there would, theoretically, be no EOF expected from this form of the monolith. It has been previously reported, however, that organic polymer monoliths produce a weak EOF without further modification [41, 42] although for the control poly(S-co-DVB) monolith the flow recorded was never higher than ca. 4 nl/min. As the photo-controllable monolith is to be used as an electroosmotic pump a more substantial EOF is required. To achieve this, protonation of the spiropyran monolith was found to be necessary. In the protonated SP form there is a localised positive charge centred on the N of the indoline ring. In contrast, in the protonated MC form, the phenylate oxygen is protonated, cancelling its negative charge, and the positive charge on the indoline ring is delocalised into the extended  $\pi$ -system. Additionally the quinonoid form of the MC is believed to be present in equilibrium with the protonated form. The presence of the quinonoid form, which has no effective charge, in parallel to the protonated MC form, reduces the number of charged sites available for generation of the



EOF. Hence, under acidic conditions, the SP-form produces a greater number of charged sites, and therefore a greater EOF effect. The mechanism we propose for the switching of the spiropyran between the SP and MC form causing the EOF to increase and decrease accordingly is shown in Fig. 8, this is similar to that proposed by Drummond and Furlong for the switching of the molecule in the presence of water/1,4-dioxane mixtures [43].

Experiments have been carried out attempting to pass current in both directions, towards the anode and towards the cathode, however EOF is only observed towards the anode indicating that the surface is always cationic, When the SP is protonated the surface of the monolith is positively charged and so the electrical double layer is made up of negative charges, which migrate towards the positive electrode. As the charge migration begins to occur electrolyte flow in the channel, or electroosmotic flow, commences, which is then measured at the anode. Irradiating at 375 nm to form the protonated MC form actually results in the formation of a two forms of the MC, a cationic and uncharged form. This reduces the effective surface charge and the electroosmotic flow slows down.

To summarise, irradiating the monolith with a white LED shifts the equilibrium state, in which the spiropyran usually resides, towards the SP form and an increase in the EOF is observed while irradiation with UV light pushes the equilibrium towards the MC form and the EOF is decreased by approx. 50%. For example, in Fig. 7, the measured EOF decreases from ca. 150 nl/min to ca. 75 nl/min at an applied field of 125 kV/m. While this flow rate is relatively low for many practical uses, it serves to prove the concept of a light-switchable electroosmotic pump. It can be noticed in Fig. 7 that there is a non-linear character to the EOF. A similar behaviour was observed by Nischang and Tallarek [44] in silica monoliths and was explained by non-equilibrium electrokinetic effects which may develop in porous media due to the presence of ion-permselective regions. It may also be due to the population effect of changing between the two states—eventually as the % in a particular form begins to dominate, the effect will diminish as there is less of the other form around to switch. Both of these possible causes are currently under investigation. With this graph, which is an average of four experiments, it is shown that the flow rate from the spiropyran based electroosmotic pump can be easily modified by irradiation with different wavelengths of light. Under acidic conditions the SP-form produces an increase in EOF while the MC form produces a decrease. Switching the wavelength of irradiation means that the flow rate can be increased or decreased without having to change the applied field. These monoliths are particularly suited to application for increasing the flow rate when using the standard method of increasing the voltage could create flow instabilities such as bubble formation in the channel. Increasing the flow by light irradiation would be a gentler method of achieving this increase. At this point in the development it would be more suited to gradient flow rate increases due to the long interconversion time; however experimentation is ongoing to improve switching efficiency.

## 4. Conclusions

A concept of an externally photo-actuated photochromic porous monolith demonstrated with a photo-controllable electroosmotic pump. The photochromic monolith is made from a photo-switchable monomer copolymerised with a divinylbenzene cross-linker. Proof has been provided that by irradiating these photochromic monoliths encased within the channels of a micro-fluidic chip, thereby converting the spiropyran molecule between its two forms, the flow rate of this electroosmotic pump can be modulated purely by applying light without having to modify the applied field.

## Acknowledgements

Z.W., S.A. and M.M would like to thank the Marie Curie Excellence Grants and Funding (MC EXT FP6/MEXT-CT-2004-014361) for financial support of this work. S.S., C.S. and D.D. would like to acknowledge financial support from Science Foundation Ireland under the CLARITY Centre award (SFI 03/IN 3/1361 and 07/RPF/MASF812). F.B.L. would also like to acknowledge financial support from the Irish Research Council for Science, Engineering and Technology (IRCSET) fellowship number 2089. The authors would also like to thank Dr. I. Nischang for useful discussions.

## References

- [1] M.S. Tsvett, *Berichte der Deutschen botanischen Gesellschaft* 24 (1906) 385.
- [2] M.S. Tsvett, *Berichte der Deutschen botanischen Gesellschaft* 24 (1906) 316.
- [3] L.S. Ettre, *Journal of Chromatographic Science* 41 (2003) 225.
- [4] G. Guiochon, *Journal of Chromatography A* 1168 (2007) 101.
- [5] M. Al-Bokari, D. Cherrak, G. Guiochon, *Journal of Chromatography A* 975 (2002) 275.
- [6] F. Svec, J.M.J. Fréchet, *Analytical Chemistry* 64 (1992) 820.
- [7] Q.C. Wang, F. Svec, J.M.J. Fréchet, *Analytical Chemistry* 65 (1993) 2243.
- [8] C. Viklund, E. Pontén, B. Glad, K. Irgum, P. Horstedt, F. Svec, *Chemistry of Materials* 9 (1997) 463.
- [9] G.F. Chen, F. Svec, D.R. Knapp, *Lab on a Chip* 8 (2008) 1198.
- [10] Q.Z. Luo, S. Mutlu, Y.B. Gianchandani, F. Svec, J.M.J. Fréchet, *Electrophoresis* 24 (2003) 3694.
- [11] C. Yu, S. Mutlu, P. Selvaganapathy, C.H. Mastrangelo, F. Svec, J.M.J. Fréchet, *Analytical Chemistry* 75 (2003) 1958.

- [12] R. Guglielmetti, in: H. Durr, H. Bouas-Laurent (Eds.), *Photochromism: Molecules and Systems*, Elsevier, Amsterdam, 2003.
- [13] E. Fischer, Y. Hirshberg, *Journal of the Chemical Society* (1952) 4522.
- [14] B.S. Lukyanov, M.B. Lukyanova, *Chemistry of Heterocyclic Compounds (Khimiya Geterotsiklicheskikh Soedinenii)* 41 (2005) 323.
- [15] C.J. Roxburgh, P.G. Sammes, *Dyes and Pigments* 27 (1995) 63.
- [16] P.M.S. Monk, R.J. Mortimer, D.R. Rosseinsky, *Electrochromism and Electrochromic Devices*, Cambridge University Press, Cambridge, UK, 2007.
- [17] R. Bertelson, *Organic Photochromic and Thermochromic Compounds*, Plenum Press, New York, 1999.
- [18] G. Such, R.A. Evans, L.H. Yee, T.P. Davis, *Journal of Macromolecular Science-Polymer Reviews C* 43 (2003) 547.
- [19] W.L. Zhao, E.M. Carreira, *Organic Letters* 7 (2005) 1609.
- [20] S. Scarmagnani, Z. Walsh, C. Slater, N. Alhashimy, B. Paull, M. Macka, D. Diamond, *Journal of Materials Chemistry* 18 (2008) 5063.
- [21] R.J. Byrne, S.E. Stitzel, D. Diamond, *Journal of Materials Chemistry* 16 (2006) 1332.
- [22] R. Matsushima, M. Nishiyama, M. Doi, *Journal of Photochemistry and Photobiology A: Chemistry* 139 (2001) 7.
- [23] P.K. Dasgupta, I.Y. Eom, K.J. Morris, J.Z. Li, *Analytica Chimica Acta* 500 (2003) 337.
- [24] S.L. McDermott, J.E. Walsh, R.G. Howard, *Optics and Laser Technology* 40 (2008) 487.
- [25] F. Benito-Lopez, S. Scarmagnani, Z. Walsh, B. Paull, M. Macka, D. Diamond, *Sensors and Actuators B-Chemical* 140 (2009) 295.
- [26] C.P. McCoy, L. Donnelly, D.S. Jones, S.P. Gorman, *Tetrahedron Letters* 48 (2007) 657.
- [27] K.D. Bartle, M.G. Cikalo, M.M. Robson, in: K.D. Bartle, P. Myers (Eds.), *Capillary Electrochromatography*, Royal Society of Chemistry, Cambridge, 2001, p. 1.
- [28] F.M. Okanda, Z. El Rassi, *Electrophoresis* 27 (2006) 1020.

- [29] F.Q. Nie, M. Macka, B. Paull, *Lab on a Chip* 7 (2007) 1597.
- [30] F.Q. Nie, M. Macka, L. Barron, D. Connolly, N. Kent, B. Paull, *Analyst* 132 (2007) 417.
- [31] S. Scarmagnani, Z. Walsh, F. Benito-Lopez, C. Slater, M. Macka, B. Paull, D. Diamond, *e-Journal of Surface Science and Nanotechnology* 7 (2009) 649.
- [32] L.M. Mathger, R.T. Hanlon, *Biology Letters* 2 (2006) 494.
- [33] S. Yoshioka, S. Kinoshita, *Journal of the Optical Society of America A-Optics Image Science and Vision* 23 (2006) 134.
- [34] A. Pauw, *American Journal of Botany* 93 (2006) 917.
- [35] F. Svec, J.M.J. Fréchet, *Industrial & Engineering Chemistry Research* 38 (1999) 34.
- [36] F. Svec, T.B. Tennikova, in: F. Svec, T.B. Tennikova, Z. Deyl (Eds.), *Monolithic Materials: Preparation, Properties and Applications*, Elsevier, Amsterdam, 2003.
- [37] Y. Kalisky, T.E. Orlowski, D.J. Williams, *Journal of Physical Chemistry* 87 (1983) 5333.
- [38] M.Q. Zhu, L.Y. Zhu, J.J. Han, W.W. Wu, J.K. Hurst, A.D.Q. Li, *Journal of the American Chemical Society* 128 (2006) 4303.
- [39] H. Kang, Y.S. Lee, E. Kim, Y. Kang, D.W. Kim, C. Lee, *Molecular Crystals and Liquid Crystals* 406 (2003) 363.
- [40] V.A. Krongauz, A. Golinelli, *Polymer Bulletin* 6 (1982) 259.
- [41] J. Dong, C.H. Xie, R.J. Tian, R.N. Wu, J.W. Hu, H.F. Zou, *Electrophoresis* 26 (2005) 3452.
- [42] L. Zhang, G. Ping, L. Zhang, W. Zhang, Y. Zhang, *Journal of Separation Science* 26 (2003) 6.
- [43] C.J. Drummond, D.N. Furlong, *Journal of the Chemical Society-Faraday Transactions* 86 (1990) 3613.
- [44] I. Nischang, U. Tallarek, *Electrophoresis* 25 (2004) 2935.

## Figures

### Figure 1

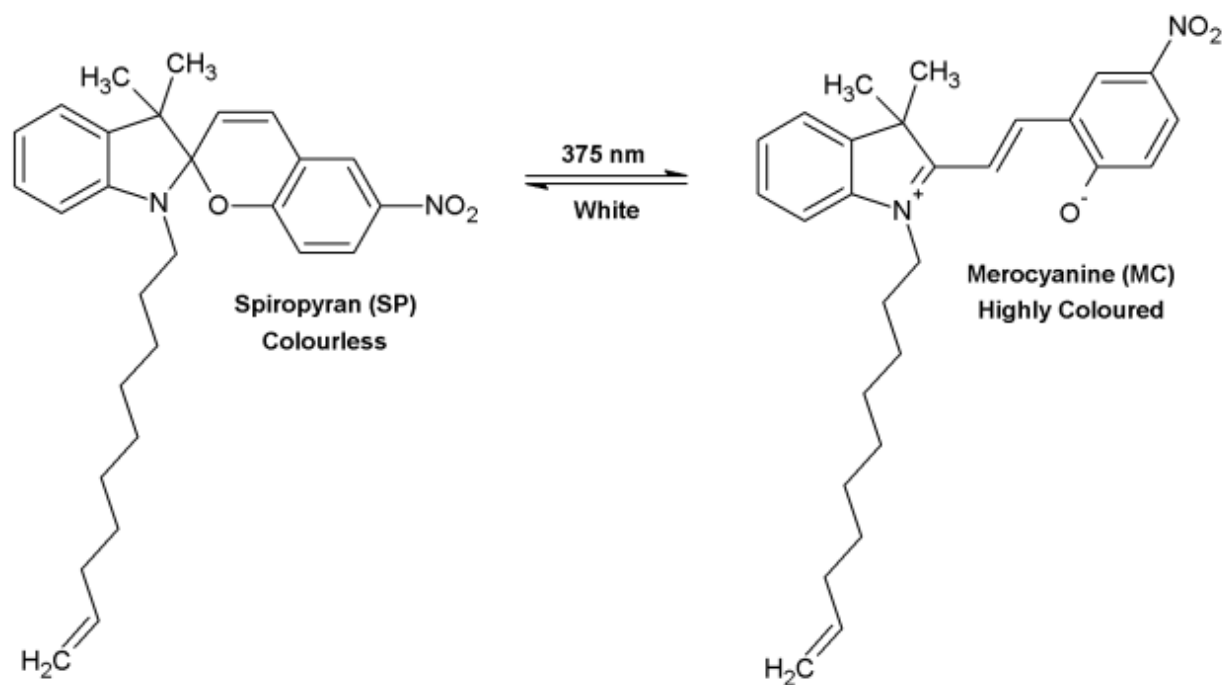

Figure 2

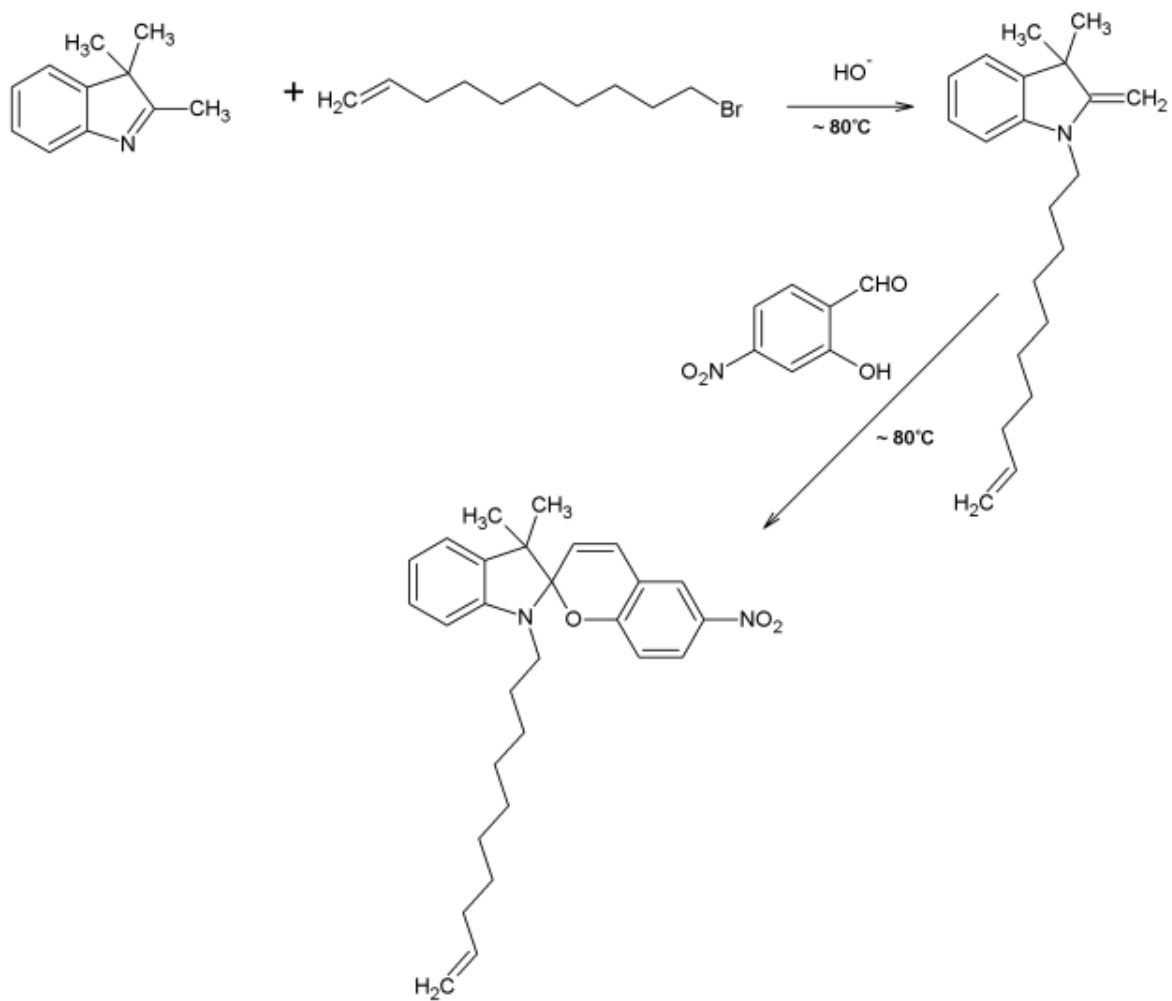

Figure 3

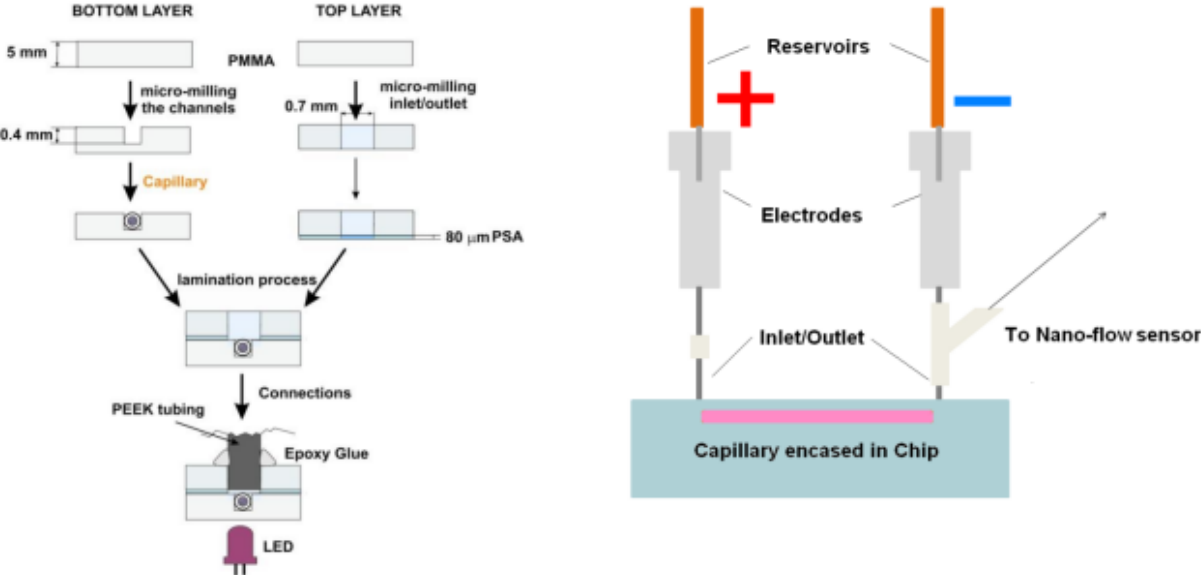

Figure 4

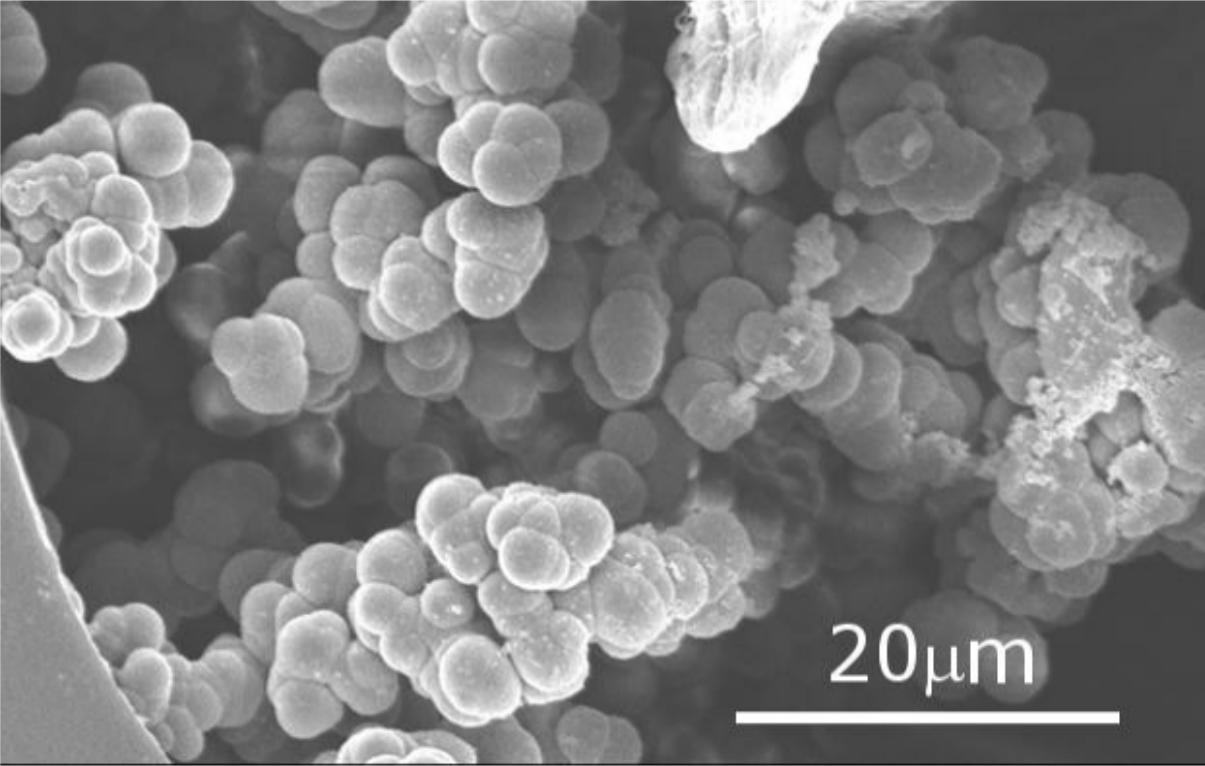

Figure 5

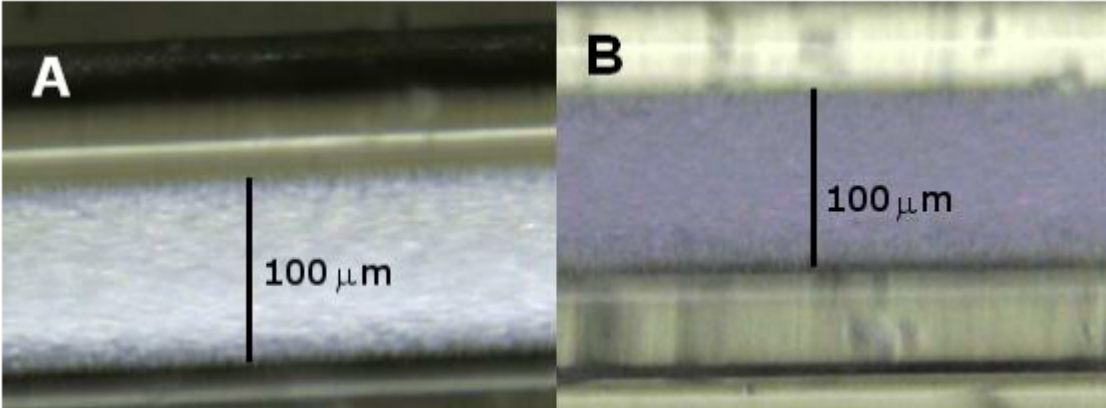

Figure 6

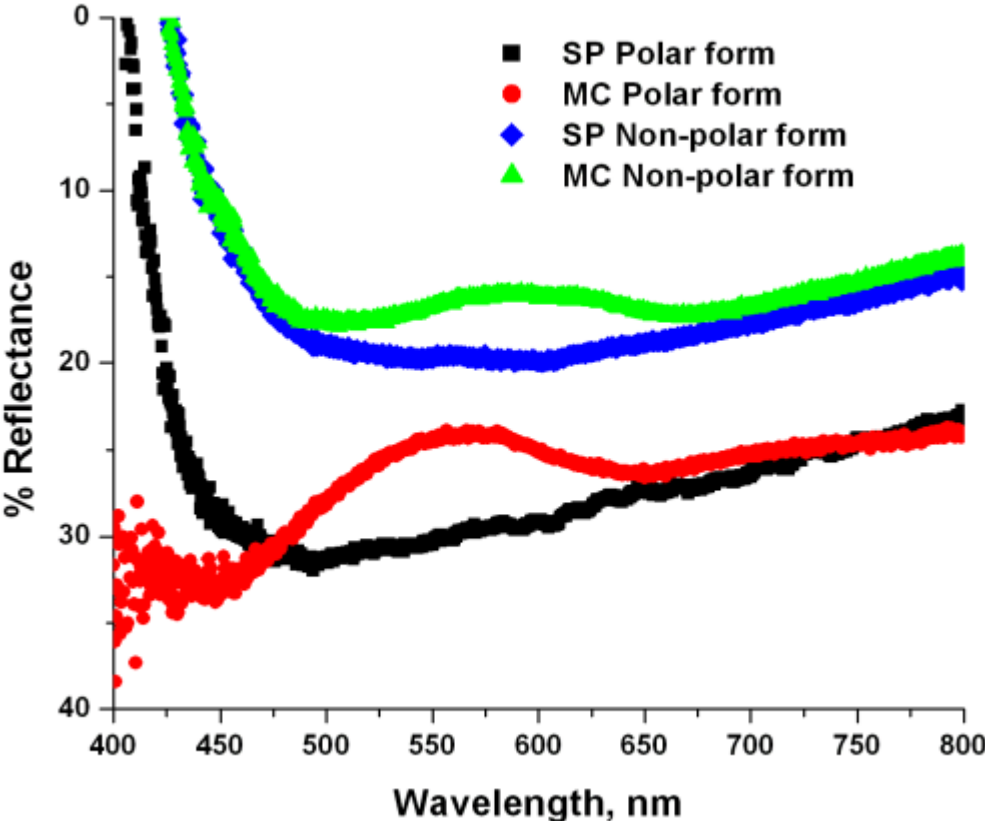



Figure 7

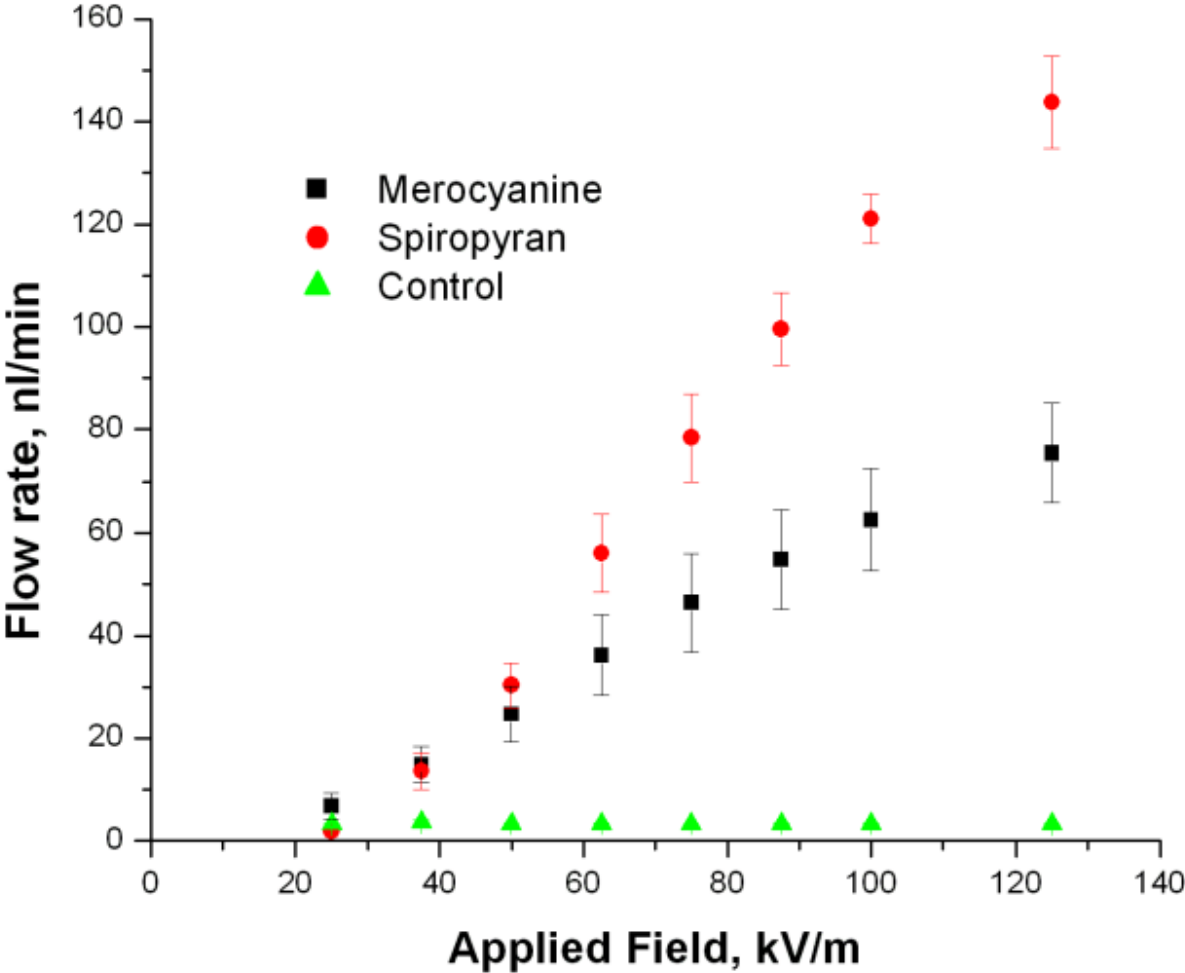
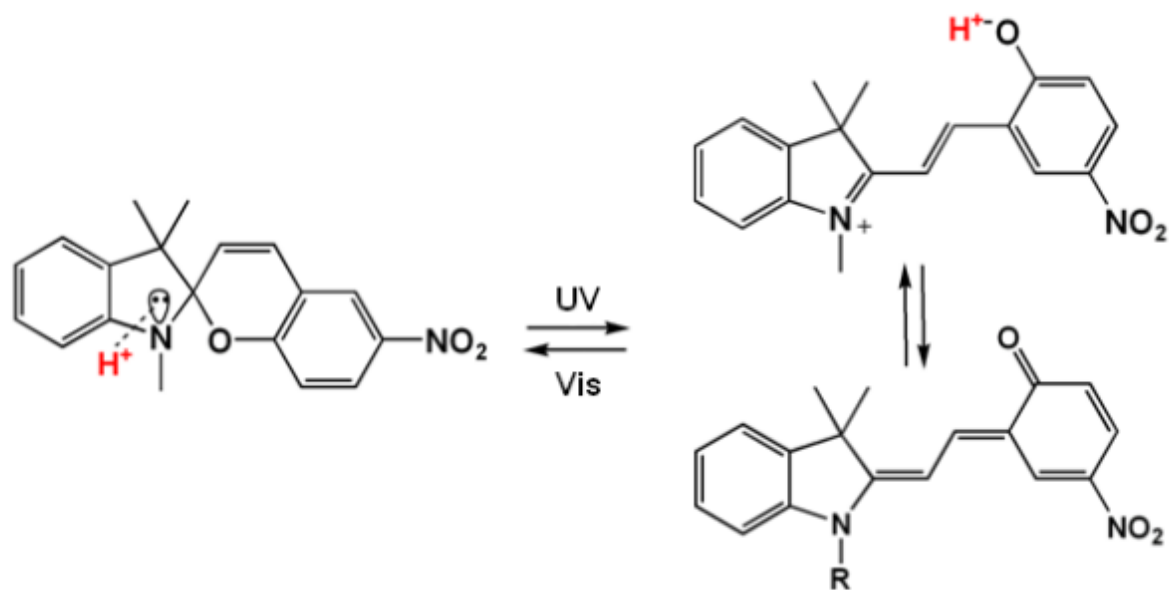

Figure 8



## **Biographies**

Zarah Walsh obtained her BSc (Hons, Chemistry with French) at Dublin City University in 2005 and recently completed a PhD in analytical chemistry at the School of Chemical Sciences of Dublin City University under the supervision of Dr. Mirek Macka and Prof. Brett Paull where she worked on the development of novel monolithic stationary phases for capillary separations.

Silvia Scarmagnani studied pharmaceutical chemistry in the University of Padua where in 2006 she received her Master degree (Honors) in “Pharmaceutical’s Chemistry and Technology”. She carried out her Master thesis, based on the synthesis of Antitumor Agents derived from Hydroxybenzaldehyde, in collaboration with Cardiff University, U.K. In 2010 she received her PhD in Chemistry from the School of Chemical Sciences of Dublin City University, Ireland where, under the supervision of Prof. Dermot Diamond, she worked on the development of adaptive surfaces for optical sensing using molecular photoswitches.

Fernando Benito López studied chemistry at the Universidad Autonoma de Madrid and completed his master studies in the group of Dr. M.J. Macazaga and Dr. R.M. Medina. He graduated with a thesis entitled “Synthesis and electrochemical study of alkynyl cobalt and osmium complexes” in 2002. He obtained his PhD at the University of Twente, Enschede, The Netherlands, under the supervision of Prof. David N. Reinhoudt and Dr. Willem Verboom, with a thesis entitled “High-pressure: a challenge for lab-on-a-chip technology” in 2007. Currently, he is a postdoctoral research fellow in the group of Prof. Dermot Diamond at Dublin City University, Dublin, Ireland.

Silvija Abele received her PhD from the Claude Bernard University Lyon I, France (Preparation and Characterization of Reactive Surfactants Derivatives of Maleic Anhydride: Utilisation in Emulsion Polymerization, 1998) and did her second post-doctoral research project in the Micro-fluidic Analysis Research group at the School of Chemical Sciences, Dublin City University, Ireland. Currently Dr. Abele is a lecturer in Analytical Chemistry at the University of Latvia. Her research interests include monolithic stationary phases for separation science and utilisation of light emitting diodes for synthesis of monoliths.

Fu-Qiang Nie obtained his B.Sc. in Materials Science in 1999 at Jinan University, China, and his PhD in the Chemistry and Physics of Polymers at Zhejiang University, China. He followed this with post-doctoral research at the Institute of Advanced Biomedical Engineering and Science (Japan) and Dublin City University. In 2008 he returned to China to take up an associate Professorship in the Institute of Chemistry at the Chinese Academy of Sciences where he works on micro-fluidics and functional interface materials.

Conor Slater received a B.Eng. and an M.Eng. from Dublin City University, Dublin, Ireland, in 2005 and 2009 respectively. He is currently a doctoral assistant at école Polytechnique Fédérale de Lausanne in

Switzerland studying ceramic packaging of electronic control systems for commercial aircraft. In 2005, he was an intern at Mitsubishi Electric Research Labs, Cambridge, MA, USA, and in 2004 he worked at BMW, Steyr, Austria designing online monitoring systems. His research interests include integrated sensing systems based on micro technology and the application of micro technology to harsh environments.

Robert Byrne studied pure and applied chemistry at Dublin City University (BSc Hons 2004) and received his PhD from Dublin City University (Materials Chemistry, 2008). His research interests include controlling molecular actuation by external stimuli for biomimetic applications.

Dermot Diamond received his PhD and DSc from Queen's University Belfast (Chemical Sensors, 1987, Internet Scale Sensing, 2002), and was VP for Research at Dublin City University (2002–2004). He has published over 200 peer-reviewed papers in international journals, is a named inventor in 13 patents, and is co-author and editor of three books. He is currently director of the National Centre for Sensor Research ([www.ncsr.ie](http://www.ncsr.ie)) and a Principle Investigator in CLARITY ([www.clarity-centre.com/](http://www.clarity-centre.com/)), a major research initiative focused on wireless sensor networks. In 2002 he was awarded the inaugural silver medal for Sensor Research by the Royal Society of Chemistry, London. Details of his research can be found at [www.dcu.ie/chemistry/asg](http://www.dcu.ie/chemistry/asg).

Brett Paull is an associate professor of analytical chemistry and Director of the Irish Separation Science Cluster at Dublin City University. Research interests include materials and their applications within separation science, bioanalytical science and environmental monitoring.

Mirek Macka received his PhD from the University of Tasmania, Australia (Separations of Metal Ions by Capillary Electrophoresis using Complexation with Metallochromic Ligands, 1997), was holder of prestigious research fellowships including recent EC senior fellowship and grant “Marie Curie Excellence Grants Fellow and Team Leader” at the School of Chemical Sciences and National Centre for Sensor Research, Dublin City University, where he is Principle Investigator Researcher, and from August 2010 he is a New Stars Professor at the University of Tasmania, Australia. He has published over 130 peer-reviewed papers in international journals. His research interests include separations by capillary electrophoresis and liquid chromatography, miniaturisation of analytical instrumentation including microfluidics, ‘exotic’ monolithic stationary phases, utilisations of solid state light sources in chemistry and life sciences and computer-based approaches in chemistry including modelling and dynamic fluidic simulations.