

## Evaluation and optimization of Laser Cutting Parameters for Plywood materials

H. A. Eltawahni<sup>a</sup>, N. S. Rossini<sup>b</sup>, M. Dassisti<sup>b</sup>, K. Alrashed<sup>c</sup>, T. Aldaham<sup>c</sup>, K. Y. Benyounis<sup>d</sup> and A. G. Olabi<sup>e</sup>

a- Mechanical Eng. Dept., University of Benghazi, P. O. Box 1308, Benghazi-Libya.

b- Mechanical and Management Engineering Department, Politecnico di Bari, Viale Japigia 182, 70126 Bari-Italy.

c- College of Technology at Al-Riyadh, Mech. Eng. Dept., P.O.Box 7650, ZIP Code 31472, Saudi Arabia.

d- Department of Industrial Engineering and Manufacturing systems, University of Benghazi, P. O. Box 1308, Benghazi-Libya.

e- School of Mech. & Manu. Eng., Dublin City University, Dublin 9, Ireland.

[hayat.eltawahni2@mail.dcu.ie](mailto:hayat.eltawahni2@mail.dcu.ie)

### ABSTRACT

Laser process parameters influence greatly the width of kerfs and quality of the cut edges. This article reports experiments on the laser plywood-cutting performance of a CW 1.5 kW CO<sub>2</sub> Rofin laser, based on design of experiments (DOE). The laser was used to cut three thicknesses 3, 6 and 9 mm of plywood panels. The process factors investigated are: laser power, cutting speed, air pressure and focal point position. The aim of this work is to relate the cutting edge quality parameters namely: upper kerf (UK), lower kerf (LK), the ratio between upper to lower kerfs and the operating cost to the process parameters mentioned above. Mathematical models were developed to establish the relationship between the process parameters and the edge quality parameters, and special graphs were drawn for this purpose. Finally, a numerical optimization was performed to find out the optimal process setting at which both kerfs would lead to a ratio of about 1, and at which low cutting cost take place.

**Keywords:** CO<sub>2</sub> laser cutting, design of experiment, plywood, optimization

### 1. Introduction

Wood is diffusely used in the building industry as a construction material. Due to its sustainability it represents an alternative to non-renewable resources such as aluminium, steel, concrete and plastics. Currently, plywood is often named as the first from the group of these products which are known as engineered wood given that it shows excellent physical and mechanical properties and it is relatively cheap [1]. Plywood has its origins in laminating veneers around 3,500 years ago in Egypt during the days of the Pharaohs. The early Greeks and Romans also used veneers and plywood mainly for furniture. From the mid 1800's modern plywood were utilized in pianos, furniture and tea chests. Plywood came of age as a versatile construction material

in the 1930's when water resistant resins were used as glues giving plywood longevity and integrity. Control of veneer surface in plywood production is essential to maintain plywood quality [2]. Rough veneers reduce contact between the layers resulting in a weak glue line and low strength properties of the plywood [3].

During 1960's the laser was discovered soon after that it becomes popular in many applications in industry especially in materials processing such as cutting of engineering structures due to its high power density and accuracy. By means of laser beam cutting (LBC) different advanced materials can be cut for example metals, plastics, rubbers, wood, ceramics and composites [4]. Some articles have been published on the laser cutting of different materials such as stainless steel and plastic materials (high-performance polyethylene and polymethyl-methacrylate) with the aim of analysing the effect of LBC parameters on quality characteristics of the cut [5 – 7]. The laser cutting of wood is one of the earliest applications of the laser processing of materials. It was successfully used in the packing industry to cut plywood mouldings in the early-1970s [8, 9]. Laser systems continue to be used in this application because of the advantage of their capability to cut complicated patterns at present. They have also found their application in the furniture industry where it is possible to get a completely automated cutting process allowing, for instance, the cutting of plywood inlays [10]. Moreover, the darkened cut surfaces obtained from the laser cut sometimes actually provide a decorative effect to the cut surface [9, 11]. Highly precise cut is one of the main advantages of laser cutting of wood in comparison with conventional cutting methods given that it is possible obtain a narrow kerf width and extremely smooth surfaces [12, 13]. Additionally, lowest presence of mechanical stress in the work piece, no tool wear, low noise emission, reduced amount of sawdust could be achieved by using this cutting method instead of conventional ones [14, 15]. Nowadays, the CO<sub>2</sub> laser is the most widely used laser in cutting operations of wood. An example of CO<sub>2</sub> laser cutting of wood is picked out in the experiment by Lum et al. [16] which aim was to determine the process parameter settings for the cutting of medium density fibreboard (MDF). The authors showed that laser cutting is a type of thermo chemical decomposition (TCD) mechanism. The energy from the laser beam acts to break chemical bonds and thus disrupt the integrity of the material. Eltawahni et al. [17] have evaluated the cutting quality of MDF wood composite material using CO<sub>2</sub> laser. The optimal cutting combinations between laser power, cutting speed, air pressure and focal point position process factors were presented in favours of high quality process output and in favours of low cutting cost. Additionally, the importance of parameters like laser power, cutting speed and shield gas to determine the cut quality for both hard and soft timber materials has been highlighted by Khan et al. [18]. Both Mukherjee et al. [13] and Khan et al. [18] have also discussed about how nozzle design and variation in shield gas velocity could improve the cutting performance

of CO<sub>2</sub> lasers on timber-based materials. Indeed, one of the important factors is laser cutting speed because higher cutting speed can bring to lower production as a result of lower cycle time. Shield gas pressure are depended upon the nozzle size and in case of supply gas in cylinder, the amount of gas remaining inside the cylinder can also affects the gas pressure. The location of the laser focal point with respect to the workpiece could influence the cutting efficiency as well as it has been underlined by Barnekov et al. [15, 19]. In their preliminary study, they have found that the severance energy which is laser power divide by material thickness for the material is about 1 Jmm<sup>-2</sup>. The same authors reported that other future research on laser cutting of wood needs to be done. The type of laser influences intensely the interaction of the laser beam with wood. In the study performed by Grad and Mozina [20] it has been proven that the CO<sub>2</sub> laser beam is absorbed almost completely by wood, which seem to be the reason why most researchers focusing on this type of laser. The same result has been achieved by Hattori [21], who discusses the laser processing of wood. The author concluded that CO<sub>2</sub> laser is the most suitable for wood processing, amongst several different types, because of CO<sub>2</sub> gas wavelength and correspondent energy density that provide a high quality of cutting. For instance, CO<sub>2</sub> laser has an higher energy density than YAG laser when interacting with wood and paper; furthermore, the orientation of a linearly polarized beam has to be considered, provided that it has an effect on the kerf shape resulting. A narrow kerf with sharp straight edges could be obtained only if the laser beam is polarized in the cutting direction. Contrariwise, if the beam is polarized forming an angle with the cut direction, the side of the cut will absorb a major laser power. As a consequence accordingly the kerf will result wider with a taper that is influenced by the angle between the cutting direction and the plane of polarization [22].

The fundamentals of LBC are mostly the same in both CO<sub>2</sub> and Nd-YAG lasers. The laser beam is focused onto the surface of the material to be cut by means of focusing lens, results in heating the material surface locally. The size of the molten volume is usually just slightly greater than the diameter of the focused beam. The molten material is ejected with the aid of high-pressure assist gas jet usually flow coaxial with the laser beam [23]. In addition to blowing the molten material away, for some materials, the type of the assist gas can improve or destroy the cutting operation by chemical reaction. However, most of non-metallic materials are been cut by CO<sub>2</sub> laser, due to they are highly absorptive at the CO<sub>2</sub> wavelength of 10.6 μm [4].

The purpose of this work is to investigate the effect of CO<sub>2</sub> laser cutting process parameters on the cut edge quality features (responses), finding out the relationship between the process parameters and the responses. An appropriate response surface methodology (RSM) technique has been adapted to this aim to reach the desired quality features at a reasonable operating cost. Finally, the

desirable and/or optimal cutting conditions can be obtained by using desirability approach and the developed models.

## **2. Experimental Work**

### **2.1 The experimental design**

Design of Experiment (DOE) and artificial neural network (ANN) of laser machining have been used in many applications of laser-cutting and laser-welding for better understanding of the relationship between laser parameters and responses, mainly with optimization purposes [24 – 31]. While ANN is a sort of “model free” technique to forecast process outcomes, DOE is far more accurate in providing statistical meanings to the causal relationship between parameters and responses. DOE is a long lasting well-assessed corpus of techniques, with several applications in the field of science and engineering for the purpose of process optimization and development, because it is essentially experimental based modelling: a good literature review on the techniques used in optimizing certain manufacturing process and the selection of the appropriate technique has been outlined by Benyounis and Olabi [27]. Accordingly, a DOE approach has been selected to be implemented in this work, in particular by adopting the Taguchi’s methodology with two level factorial design, which have the lower number of runs to study a multifactor and multi-responses process such as the laser cutting. Unfortunately, the two-level FD involve some restrictions given that the quadratic effect cannot be determined using (it is a screen design); to the same extent some of the interactions between the factors affecting the process cannot be determined using Taguchi methodology due to the aliased structures, which means not all the interaction effects can be estimated [28]. Conversely, RSM offers interesting features in analyzing the relationship and the influences of input machining parameters on the responses [24, 25, 29], making possible to find out all the factor’s effects and their interactions. In fact, in Eq.1 below  $x_i$  terms are the input variables that influence the response  $y$ , and  $b_0$ ,  $b_i$ , and  $b_{ij}$  are estimated regression coefficients, while  $\varepsilon$  is the experimental error; the first summation term represents the main factor effects, the second term stands for the quadratic effects and the third term represents the two factor interaction effects. Therefore, RSM was chosen by implementing Box-Behnken design, which is a three level design and it is able to investigate the process with a relatively small number of runs as compared with the central composite design [27, 28]. This design characterizes with its operative region and study region are the same, which would lead to investigate each factor over its whole range, which is a competitive advantage for this design over the central composite design [17]:

$$y = b_o + \sum b_i \chi_i + \sum b_{ii} \chi_{ii}^2 + \sum b_{ij} \chi_i \chi_j + \varepsilon \quad (1)$$

If all independent variables were measurable and can be repeated with negligible error, the response surface can be expressed by:

$$y = f(x_1, x_2, \dots, x_k) \quad (2)$$

where k is the number of independent variables.

To optimise the “y” response it is necessary to find an appropriate approximation for the true functional relationship between the independent variables and the response surface. Usually a second order polynomial Eq.1 is used in RSM. The values of the coefficients  $b_0$ ,  $b_i$ ,  $b_{ii}$  and  $b_{ij}$  can be calculated using regression analysis. The F statistics for significance effects of the model can be computed by means of analysis of variance (ANOVA).

In this study four process parameters are considered, namely: laser power, cutting speed, air pressure and focal point position. Table 1 shows process input parameters and experimental design levels used for the three thicknesses (3, 6 and 9 mm). The experimental data was analysed by statistical software, Design-Expert V7. Second order polynomials were fitted to the experimental data to obtain the regression equations. The sequential F-test and other adequacy measures were carried out to select the best fit. A step-wise regression method was used to fit the second order polynomial Eq. 1 to the experimental data and to find the significant model terms [28, 32]. The same statistical software was used to generate the statistical and response plots as well as the optimization.

Table 1: Process variables and experimental design levels.

Parameter	Code	Unit	Levels								
			-1			0			+1		
			Thickness, mm			Thickness, mm			Thickness, mm		
			3	6	9	3	6	9	3	6	9
Laser power	A	W	120	225	375	210	412.5	562.5	300	600	750
Cutting speed	B	mm/min	2500	2000	2000	3750	3500	3500	5000	5000	5000
Air pressure	C	bar	1	2	2	2	3	3.5	3	4	5
Focal point position	D	mm	-3	-6	-7.5	-1.5	-3	-3.75	0	0	0

The main experiment was performed as per the design matrix in a random order to avoid an systematic error.

## 2.2 Experimental settings

The specimen used were dry sheet panels of plywood composite of 500 x 500 mm dimensions, with thicknesses of 3, 6 and 9 mm. Trial laser cut runs were initially carried out by varying one of the process factors at-a-time to find out the best ranges for laser power, cutting speed, air pressure and focal point position factors. Full cut, with an acceptable kerf width, cutting edge striations and dross were the criteria of selecting the working ranges for all factors. A CW 1.5 kW CO<sub>2</sub> Rofin laser with a linear polarized beam angled at 45° provided by Mechtronic Industries Ltd. A focusing lens with a focal length of 127 mm was used to perform the cut. Fig. 1 illustrates the location of the focal plane relative to the upper surface for 6 mm plywood board. As reported in [16] there is no significant reduction in the kerf width when using either the compressed air or nitrogen. In addition, the compressed air is cheaper than nitrogen. Therefore compressed air was supplied coaxially as an assist gas with different pressures. Furthermore, the compressed air system was used to remove smoke and fumes generated by the laser cutting operation. The nozzle used has a conical shape with nozzle diameter of 1.5 mm. The stand-off-distance was kept to 0.5 mm. Specimens were cut from the panel for each condition. The specimen shape was designed as shown in Fig. 2(a), in order to allow the measurement of all responses in an accurate and simple way. The upper and lower kerf width “responses” were measured using an optical microscope with digital micrometers attached to it with an accuracy of 0.001 mm, which allows measurement in both X-axis and Y-axis. An average of three measurements of both kerf widths was recorded for all runs. Fig. 2(c-b) illustrates a photograph of UK and LK of a plywood specimen taken by the optical microscope. As can be seen from these pictures, the presence of charring on the cutting edges is minimal and it did not significantly affect the quality of the cut for all the three thicknesses. The ratio of the upper kerf to the lower kerf was calculated for each run using the averaged data.

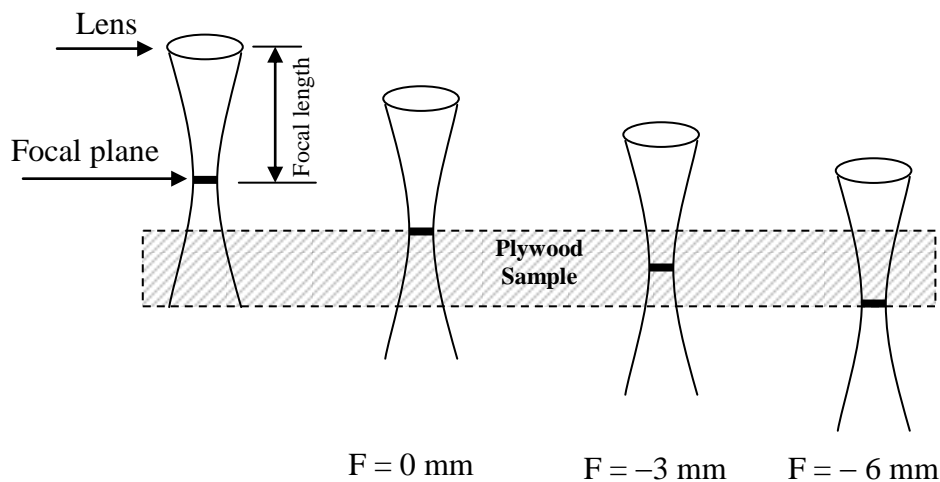
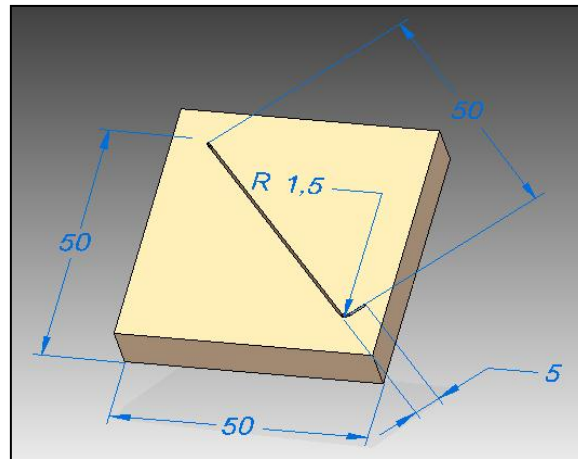
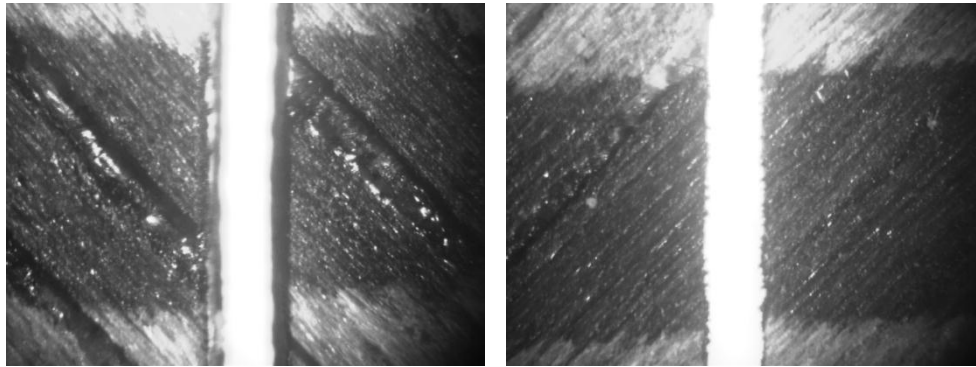

Fig. 1: Schematic plot showing the location of the focus of the beam relative to the upper surface.



(a)



(b)

(c)

Fig. 2(a-c): Specimen shape designed by Solid Edge software(a); upper kerf (b) and lower kerf (c) width of a plywood specimen shown by optical microscope.

### 2.2.1 Estimation of the laser-cutting operating cost

Laser-cutting operating costs can be estimated as cutting per working hours or per unit length. The laser system used in this work utilized CO<sub>2</sub> using a static volume of laser gases of approximately 7.5 litre every 72 hour. For this laser system with 1.5 kW maximum outputs power the operating costs generally falls into the categories listed in Table 2, where the value 0.8 pf, in the first two element costs, represents the power factor of the AC electrical power system used. The operating cost calculation does not account the unscheduled breakdown and maintenance, such as breakdown in the table motion controller or PC hard disc replacement. The total approximated operating cost per working hours as a function of process parameters can be estimated by  $2.654 + 1.376xP + 1.3718x10^{-5}xP$ . While the total approximated operating cost per unit length of the cut is

given by Eq. 3 assuming 85% utilization. Eq. 3a was used to calculate the cutting cost per meter for all samples and the results were presented in Tables 3-5.

Table 2: Operating costs breakdown.

Element of cost	Calculations	Cutting cost €/hr
Laser electrical power	(20.88 kVA)(0.8 pf)( € 0.12359/kWhr)x(P/1.5)	1.376xP
Chiller electrical power	(11.52 kVA)(0.8 pf)( € 0.12359/kWhr)	1.139
Motion controller power	(4.8 kVA)(0.8 pf)( € 0.12359/kWhr)	0.475
Exhaust system power	(0.9 kWhr)( € 0.12359/kWhr)	0.111
Laser gas LASPUR208	{(€1043.93/ bottle)/(1500liter/bottle)} x 7.5Liter/72hr	0.072
Gas bottle rental	(€181.37/720hr)	0.252
Chiller additives	(€284.80/year)/(8760 hr/year)	0.033
Compressed air	(0.111 kW/m <sup>3</sup> )(€0.12359/kWhr)x(m <sup>3</sup> /1000liter)	1.3718x10 <sup>-5</sup> [€/l] x F[l/hr]
Nozzle tip	(€7.20/200hr)	0.036
Exhaust system filters	(€5/100hr)	0.05
Focus lens	(€186/lens)/(1000hr)	0.186
Maintenance labour (with overhead)	(12 hr/2000hrs operation)(€50/hr)	0.30
Total operation cost per working hours		2.654+1.376xP +1.3718x10 <sup>-5</sup> xF

$$\text{Cutting cost[Euro/m]} = \frac{2.654 + 1.376 \times P [\text{kW}] + 1.3718 \times 10^{-5} \times F [\text{l/hr}]}{(0.85) \times S [\text{mm/min}] [60 \text{min/hr}] [m/1000 \text{mm}]} \quad (3)$$

$$\text{Cutting cost[Euro/m]} = \frac{2.654 + 1.376 \times P + 1.3718 \times 10^{-5} \times F}{0.051 \times S} \quad (3a)$$

Where

P: used output power in kW.

F: flow rate in l/hr.

S: cutting speed in mm/min.

At pressure above 0.89 bar the compressed air will flow in a supersonic manner. Note that this pressure value (0.89 bar) is independent of nozzle diameter [33]. At pressure above this threshold the flow rate in [l/hr] of the compressed air through a nozzle can be easily calculated from Eq. 4 [17].



$$\text{Flow rate} = F[\text{l/hr}] = 492 \times d^2 (p_g + 1) \quad (4)$$

Where:

d: Nozzle diameter [mm].

P<sub>g</sub>: Nozzle supply pressure [bar].

### 3. Results and discussion

The outputs of the experiments and the average measured responses for each thickness are presented in Tables 3-5. The upper and lower kerf were measured by an optical microscope as discussed above, while the operating cost were obtained using Eqs 3a and 4.

Table 3: Design matrix and experimentally recorded responses for thickness 3 mm.

Std	Run	Factors				Responses			
		A: Laser power, W	B: Cutting speed, mm/min	C: Air pressure, bar	D : Focal position, mm	Upper kerf, mm	Lower kerf, mm	Ratio	Cost €/m
1	6	120	2500	2	-1.5	0.303	0.156	1.944	0.0225
2	8	300	2500	2	-1.5	0.382	0.380	1.005	0.0244
3	18	120	5000	2	-1.5	0.290	0.137	2.122	0.0112
4	19	300	5000	2	-1.5	0.348	0.298	1.170	0.0122
5	2	210	3750	1	-3	0.637	0.151	4.226	0.0155
6	25	210	3750	3	-3	0.607	0.179	3.389	0.0157
7	28	210	3750	1	0	0.364	0.221	1.643	0.0155
8	11	210	3750	3	0	0.332	0.181	1.831	0.0157
9	7	120	3750	2	-3	0.481	0.136	3.548	0.0150
10	17	300	3750	2	-3	0.551	0.248	2.223	0.0163
11	24	120	3750	2	0	0.266	0.125	2.132	0.0150
12	9	300	3750	2	0	0.322	0.257	1.254	0.0163
13	20	210	2500	1	-1.5	0.331	0.218	1.520	0.0233
14	1	210	5000	1	-1.5	0.296	0.182	1.622	0.0117
15	27	210	2500	3	-1.5	0.345	0.232	1.489	0.0236
16	13	210	5000	3	-1.5	0.273	0.193	1.419	0.0118
17	12	120	3750	1	-1.5	0.324	0.139	2.334	0.0149
18	29	300	3750	1	-1.5	0.348	0.251	1.388	0.0162
19	3	120	3750	3	-1.5	0.310	0.137	2.271	0.0151
20	21	300	3750	3	-1.5	0.285	0.201	1.417	0.0164
21	5	210	2500	2	-3	0.540	0.184	2.935	0.0234
22	10	210	5000	2	-3	0.501	0.153	3.265	0.0117
23	4	210	2500	2	0	0.311	0.264	1.178	0.0234
24	16	210	5000	2	0	0.287	0.200	1.434	0.0117
25	14	210	3750	2	-1.5	0.313	0.229	1.368	0.0156
26	23	210	3750	2	-1.5	0.333	0.247	1.347	0.0156
27	26	210	3750	2	-1.5	0.339	0.238	1.421	0.0156
28	15	210	3750	2	-1.5	0.322	0.229	1.406	0.0156
29	22	210	3750	2	-1.5	0.319	0.217	1.470	0.0156

Table 4: Design matrix and experimentally recorded responses for thickness 6 mm.

Std	Run	Factors				Responses			
		A: Laser power, W	B: Cutting speed, mm/min	C: Air pressure, bar	D : Focal position, mm	Upper kerf, mm	Lower kerf, mm	Ratio	Cost €/m
1	13	225	2000	3	-3	0.404	0.313	1.288	0.0297
2	27	600	2000	3	-3	0.567	0.506	1.121	0.0347
3	9	225	5000	3	-3	0.348	0.252	1.383	0.0119
4	12	600	5000	3	-3	0.486	0.390	1.246	0.0139
5	14	412.5	3500	2	-6	0.836	0.373	2.242	0.0183
6	18	412.5	3500	4	-6	0.790	0.320	2.472	0.0185
7	17	412.5	3500	2	0	0.340	0.405	0.838	0.0183
8	11	412.5	3500	4	0	0.364	0.403	0.903	0.0185
9	5	225	3500	3	-6	0.811	0.315	2.576	0.0169
10	3	600	3500	3	-6	0.885	0.420	2.109	0.0198
11	10	225	3500	3	0	0.279	0.165	1.691	0.0169
12	20	600	3500	3	0	0.374	0.496	0.754	0.0198
13	29	412.5	2000	2	-3	0.509	0.450	1.131	0.0320
14	23	412.5	5000	2	-3	0.456	0.353	1.292	0.0128
15	4	412.5	2000	4	-3	0.503	0.427	1.178	0.0323
16	6	412.5	5000	4	-3	0.470	0.350	1.343	0.0129
17	19	225	3500	2	-3	0.511	0.302	1.689	0.0169
18	16	600	3500	2	-3	0.574	0.382	1.502	0.0197
19	22	225	3500	4	-3	0.494	0.318	1.556	0.0170
20	26	600	3500	4	-3	0.588	0.421	1.398	0.0199
21	21	412.5	2000	3	-6	0.970	0.496	1.956	0.0322
22	28	412.5	5000	3	-6	0.888	0.395	2.248	0.0129
23	15	412.5	2000	3	0	0.377	0.467	0.807	0.0322
24	2	412.5	5000	3	0	0.322	0.369	0.874	0.0129
25	25	412.5	3500	3	-3	0.551	0.417	1.320	0.0184
26	24	412.5	3500	3	-3	0.525	0.342	1.536	0.0184
27	7	412.5	3500	3	-3	0.520	0.386	1.348	0.0184
28	8	412.5	3500	3	-3	0.527	0.337	1.566	0.0184
29	1	412.5	3500	3	-3	0.542	0.398	1.361	0.0184

Table 5: Design matrix and experimentally recorded responses for thickness 9 mm.

Std	Run	Factors				Responses			
		A: Laser power, W	B: Cutting speed, mm/min	C: Air pressure, bar	D : Focal position, mm	Upper kerf, mm	Lower kerf, mm	Ratio	Cost €/m
1	18	375	2000	3.5	-3.75	0.550	0.483	1.139	0.0317
2	17	750	2000	3.5	-3.75	0.617	0.657	0.940	0.0368
3	19	375	5000	3.5	-3.75	0.387	0.321	1.205	0.0127
4	22	750	5000	3.5	-3.75	0.483	0.570	0.847	0.0147
5	12	562.5	3500	2	-7.5	0.869	0.325	2.671	0.0195
6	10	562.5	3500	5	-7.5	0.916	0.345	2.652	0.0197
7	3	562.5	3500	2	0	0.371	0.408	0.909	0.0195
8	23	562.5	3500	5	0	0.344	0.435	0.792	0.0197
9	6	375	3500	3.5	-7.5	0.871	0.204	4.263	0.0181
10	2	750	3500	3.5	-7.5	0.956	0.362	2.640	0.0210
11	5	375	3500	3.5	0	0.353	0.278	1.273	0.0181
12	11	750	3500	3.5	0	0.377	0.542	0.696	0.0210
13	15	562.5	2000	2	-3.75	0.602	0.565	1.066	0.0341
14	21	562.5	5000	2	-3.75	0.456	0.392	1.164	0.0136
15	29	562.5	2000	5	-3.75	0.624	0.562	1.110	0.0345
16	16	562.5	5000	5	-3.75	0.595	0.433	1.372	0.0138
17	9	375	3500	2	-3.75	0.521	0.285	1.826	0.0180
18	24	750	3500	2	-3.75	0.620	0.474	1.310	0.0209
19	4	375	3500	5	-3.75	0.553	0.323	1.710	0.0183
20	8	750	3500	5	-3.75	0.580	0.516	1.124	0.0212
21	1	562.5	2000	3.5	-7.5	0.913	0.320	2.854	0.0343
22	25	562.5	5000	3.5	-7.5	0.895	0.390	2.296	0.0137
23	13	562.5	2000	3.5	0	0.415	0.631	0.659	0.0343
24	28	562.5	5000	3.5	0	0.348	0.392	0.887	0.0137
25	7	562.5	3500	3.5	-3.75	0.567	0.427	1.329	0.0196
26	14	562.5	3500	3.5	-3.75	0.575	0.460	1.249	0.0196
27	26	562.5	3500	3.5	-3.75	0.581	0.433	1.344	0.0196
28	20	562.5	3500	3.5	-3.75	0.585	0.425	1.377	0.0196
29	27	562.5	3500	3.5	-3.75	0.588	0.399	1.475	0.0196

### 3.1 Analysis of Variance

The test for significance of the regression models, test for significance on each model coefficients were carried out. Step-wise regression method was selected to select the significant model terms automatically. The resultant 12 ANOVA tables for the reduced quadratic models summarize the analysis of variance of each response and show the significant model terms, but to avoid any confusion for the reader these tables were abstracted to present only the most important information as shown in Table 6. The DF value of each model is calculated as the sum of the DF values of all the factors, quadratic effects, and the interaction effects associated with the considered

response. This table shows also the other adequacy measures  $R^2$ , adjusted  $R^2$  and predicted  $R^2$ . The entire adequacy measures are close to 1, which is in reasonable agreement and indicate adequate models. The values of adequacy measures are good as compared with the values listed in [24, 25].

Table 6: Synthesis of the ANOVA analysis - all the reduced quadratic models.

Thickness, mm	Response	SS <sub>-model</sub>	DF	Prob. >F Model	R <sup>2</sup>	Adj- R <sup>2</sup>	Pre- R <sup>2</sup>
3	Upper kerf	0.27	6	< 0.0001 (Sig.)	0.9284	0.9089	0.8643
	Lower kerf	0.075	6	< 0.0001 (Sig.)	0.8307	0.7846	0.6864
	Ratio	17.59	6	< 0.0001 (Sig.)	0.9399	0.9235	0.8537
	Cost	0.0004447	6	< 0.0001 (Sig.)	1.0000	0.9999	0.9999
6	Upper kerf	0.93	4	< 0.0001 (Sig.)	0.9546	0.9471	0.9300
	Lower kerf	0.13	6	< 0.0001 (Sig.)	0.8330	0.7875	0.6627
	Ratio	6.22	5	< 0.0001 (Sig.)	0.9233	0.9066	0.8719
	Cost	0.001270	5	< 0.0001 (Sig.)	0.9998	0.9997	0.9993
9	Upper kerf	0.94	4	< 0.0001 (Sig.)	0.9647	0.9588	0.9463
	Lower kerf	0.32	8	< 0.0001 (Sig.)	0.9577	0.9408	0.8954
	Ratio	17.15	6	< 0.0001 (Sig.)	0.9219	0.9006	0.7809
	Cost	0.001437	5	< 0.0001 (Sig.)	0.9998	0.9997	0.9994

The final mathematical models in terms of coded factors are provided in the Eqs 5- 16 below, where A is the laser power in Watt, B is the cutting speed in mm/min, C is the air pressure in bar and D is the focal position in mm.

Eqs 5-8 give mathematical models for 3 mm thick plywood.

$$\text{Upper kerf} = 0.31 + 0.022*A - 0.018*B - 0.012*C - 0.12*D + 0.021*C^2 + 0.11*D^2 \quad (5)$$

$$\text{Lower kerf} = 0.23 + 0.067*A - 0.023*B - 0.003250*C + 0.016*D - 0.031*C^2 - 0.029*D^2 \quad (6)$$

$$\text{Ratio} = 1.42 - 0.49*A - 0.076*C - 0.84*D + 0.26*CD + 0.33*C^2 + 0.90*D^2 \quad (7)$$

$$\begin{aligned} \text{Operating Cost} = & 0.016 + 0.0006745*A - 0.005860*B + 0.00008271*C - 0.0002428*AB \\ & - 0.00002978*BC + 0.001953*B^2 \end{aligned} \quad (8)$$

Eqs 9-12 give mathematical models for 6 mm thick plywood.

$$\text{Upper kerf} = 0.50 + 0.052*A - 0.030*B - 0.26*D + 0.099*D^2 \quad (9)$$

$$\begin{aligned} \text{Lower kerf} = & 0.38 + 0.079*A - 0.046*B - 0.001056*D + 0.057*AD - 0.033*A^2 \\ & + 0.028*B^2 \end{aligned} \quad (10)$$

$$\text{Ratio} = 1.48 - 0.17*A + 0.075*B - 0.64*D - 0.23*B^2 + 0.22*D^2 \quad (11)$$

$$\text{Operating Cost} = 0.018 + 0.001554*A - 0.009654*B + 0.00009.146*C - 0.0007588*AB + 0.004137*B^2 \quad (12)$$

Eqs 13-16 provide mathematical models for 9 mm thick plywood.

$$\text{Upper kerf} = 0.56 + 0.033*A - 0.047*B - 0.27*D + 0.078*D^2 \quad (13)$$

$$\text{Lower kerf} = 0.42 + 0.10*A - 0.060*B + 0.014*C + 0.062*D + 0.027*AD - 0.077*BD + 0.078*B^2 - 0.058*D^2 \quad (14)$$

$$\text{Ratio} = 1.42 - 0.32*A + 0.0002553*B - 1.01*D + 0.26*AD - 0.31*B^2 + 0.57*D^2 \quad (15)$$

$$\text{Operating Cost} = 0.020 + 0.001554*A - 0.010*B + 0.0001372*C - 0.0007588*AB + 0.004407*B^2 \quad (16)$$

### 3.3 Adequacy of the Developed models

The adequacy and the improvement of the developed models were tested by three confirmation experiments, carried out using different test conditions at different parameters conditions; these experiments were selected from the optimization results, using the first optimal solution related to the first optimization criterion for each plywood thickness. The predicted values of UK, LK, ratio and operating cost, for validation experiments were calculated using the point prediction option in the Design-Expert software and the developed mathematical models. Table 7 presents the experimental conditions, the actual experimental values, the predicted values and the percentages of error for all thicknesses. Comparing the percentage error for all the four responses it is possible to conclude that experimental conclusions here drawn are in reasonable agreement with others obtained in [6, 17 and 24].

Table 7: Confirmation experiments.

Thickness, mm	Factors				Values	Responses			
	A, W	B, mm/min	C, bar	D, mm		Upper kerf, mm	Lower kerf, mm	Ratio	Cost, €/m
3	278.39	4891.45	1.46	-0.21	Actual	0.294	0.262	1.122	0.0123
					Predicted	0.306	0.247	0.999	0.0122
					Error %	-4.082	5.725	10.973	0.813
6	336.39	4908.86	3.63	-0.10	Actual	0.279	0.288	0.969	0.0127
					Predicted	0.296	0.301	1	0.0127
					Error %	-6.093	-4.514	-3.226	0
9	411.25	2761.77	4.72	-0.91	Actual	0.386	0.419	0.921	0.0235
					Predicted	0.396	0.421	0.999	0.0243
					Error %	-2.591	-0.477	-8.441	-3.404

## 3.5 Discussion

### 3.5.1 Upper kerf

Fig. 3(a-c) perturbation plots shows the main effect of the considered cutting parameters on the upper kerfs responses for all thicknesses. The perturbation plot would help to compare the effect of all the factors at a particular point in the design space. This type of display does not show the effect of interactions. The lines represent the behaviours of each factor while holding the others in a constant ratio. In the case of more than one factor this type of display could be used to find those factors that most affect the response. Note that the paths emanate from the centre point. This reference point on the perturbation plot can be changed. The final optimum makes a good reference point from which one can see how sensitive the response becomes to the process factors. Taking a look at this graph it is clear that the factor which has the major effect on the upper kerf is the focal point position. Particularly, the upper kerf decreases as the focal point position increases. This result confirms the theory that the smallest spot size of the laser beam is present on the surface when the focal point is precisely on the surface and consequently the laser power will localize in narrow area. Conversely, if the beam is defocused below the surface, the laser power will spread onto wider area on the surface and accordingly it will lead to a wider upper kerf. Both the laser power and cutting speed are also influencing the upper kerf as it is shown from the same figure. However, the upper kerf increases as the cutting speed decreases while it increases as the laser power increases. This is in agreement with the logic as carrying out laser-cutting with a slow cutting speed more materials will be melted and ejected causing the upper kerf to increase given that more heat would be brought to the sample. As regards laser power effect, increasing the laser power, the upper kerf would increase owing to the increase in the heat input as a result of the increase in the laser power. These results agree well enough with the results obtained in the reference [32]. Lastly, it is evident that the upper kerf decreases slightly as the gas pressure increases. However, the effect of the gas pressure on the average upper kerf exists only for 3 mm thick plywood and it disappears for 6 and 9 mm thick plywood. The change of focal position, cutting speed and laser power factors from its lowest value to its highest value while keeping the other factors at their centre values will bring to a percentages change in the upper kerf as follows (the percentages are for 3 mm, 6 mm and 9 mm thick, respectively): (a) changing focal position would lead up to a decrease of 43.77%, 60.25% and 59.25%; (b) changing the cutting speed would lead up to a decrease of 10.94%, 11.24% and 15.54%; (c) changing the laser power would lead up to an increase of 15.22%, 23.23% and 12.57%. The change in the upper kerf as a result of changing air pressure for the 3 mm thick consists of a decrease of just 7.25%.

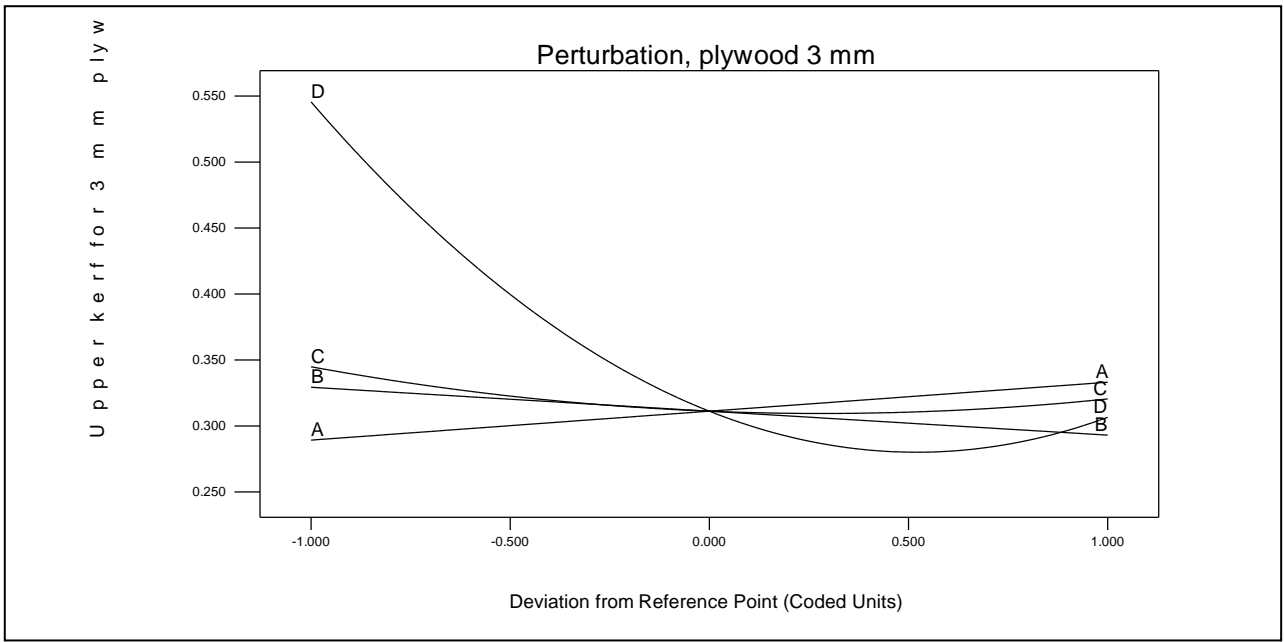

(a)

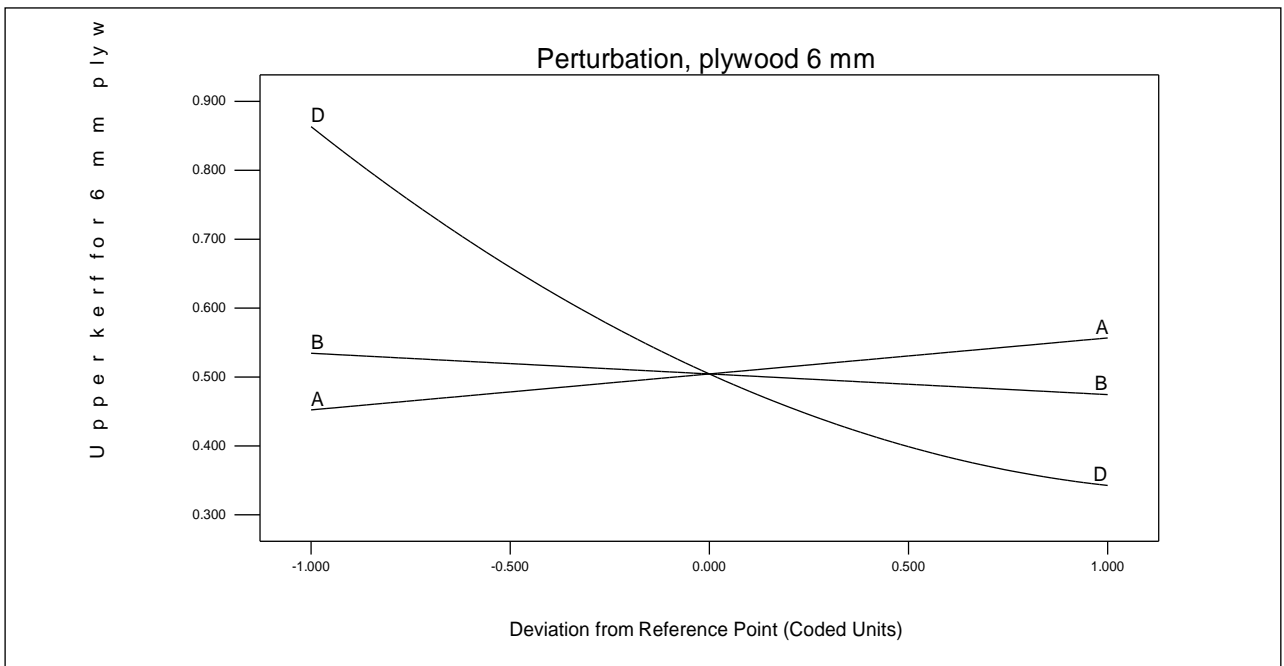

(b)

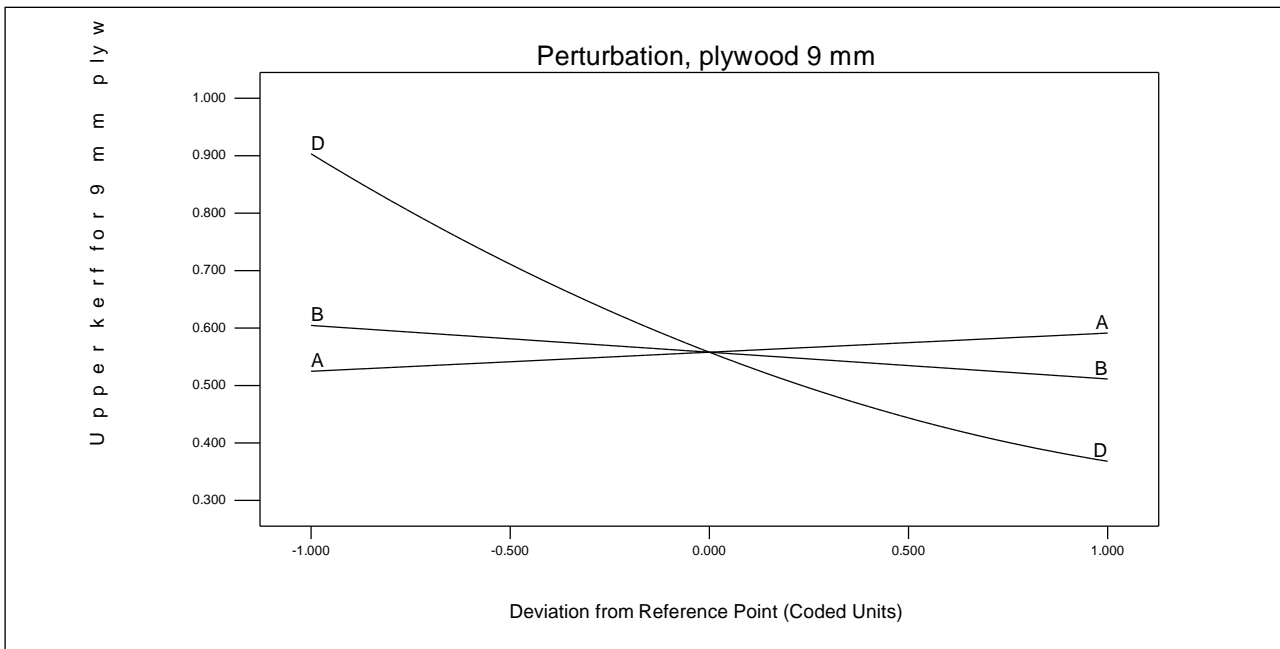

(c)

Fig. 3(a-c): Perturbation plots showing the effect of each factor on the average upper kerf for the (a) 3 mm thick, (b) 6 mm thick and (c) 9 mm thick.

### 3.5.2 Lower kerf

Fig. 4(a-c) perturbation plots show the average lower kerf widths for all thicknesses. In this plot it is clear that the major factors, which have an effect on the lower kerf, are the laser power, the cutting speed and the focal position. These results confirmed the results obtained in the reference [32] that is to say the lower kerf decreases as the cutting speed increases. Furthermore, the lower kerf increases as the laser power increases and this agrees well enough with the results found in the literatures. Additionally, the lower kerf increases as the focal point position increases for 3 mm thick and 9 mm thick plywood while the effect is almost null for the 6 mm thick. So, as already mentioned above, the lower kerf will increase when a focused beam is used given that the laser power would spread on the bottom surface onto a wider area, as the beam is becoming wider at the bottom of the sample. Finally, the air pressure has a very small effect on the average lower kerf for 3 mm thick and 9 mm thick plywood only. The change of laser power, cutting speed and focal position factors from its lowest value to its highest value while keeping the other factors at their centre values will bring to a percentages change in the lower kerf as follows (the percentages are for 3 mm, 6 mm and 9 mm thick, respectively): (a) changing laser power would result in an increase of 82.32%, 58.96% and 64.56%; (b) changing the cutting speed would result in a decrease of 17.72%, 20.26% and 21.58%; (c) changing the focal position would result in an increase of 17.46%, a



decrease of 0.52% and an increase of 41.14%. The percentages of changes in the lower kerf as a result of changing air pressure for the 3 mm thick and 9 mm thick consist of a decrease of 2.90% and an increase of 6.93%. Fig. 5 exhibits the interaction of the laser power with the focal point position on the average lower kerf for the 6 mm thick. It is evident that to achieve a narrow lower kerf at higher laser power above 417 W it is necessary using focal point position of -6 mm. Conversely, a narrower average lower kerf could be obtained by using lower laser power less than 417 W and a focused beam. Fig. 5 demonstrates the interaction of the cutting speed with the focal point position on the average lower kerf for the 9 mm thick. From Fig. 6 it is clear that at slower cutting speed less than 4698.08 mm/min a narrower lower kerf would be achieved by using focal point position of -7.50 mm. On the other hand, a narrower average lower kerf could be obtained by using faster cutting speed above 4698.08 mm/min and a focused beam.

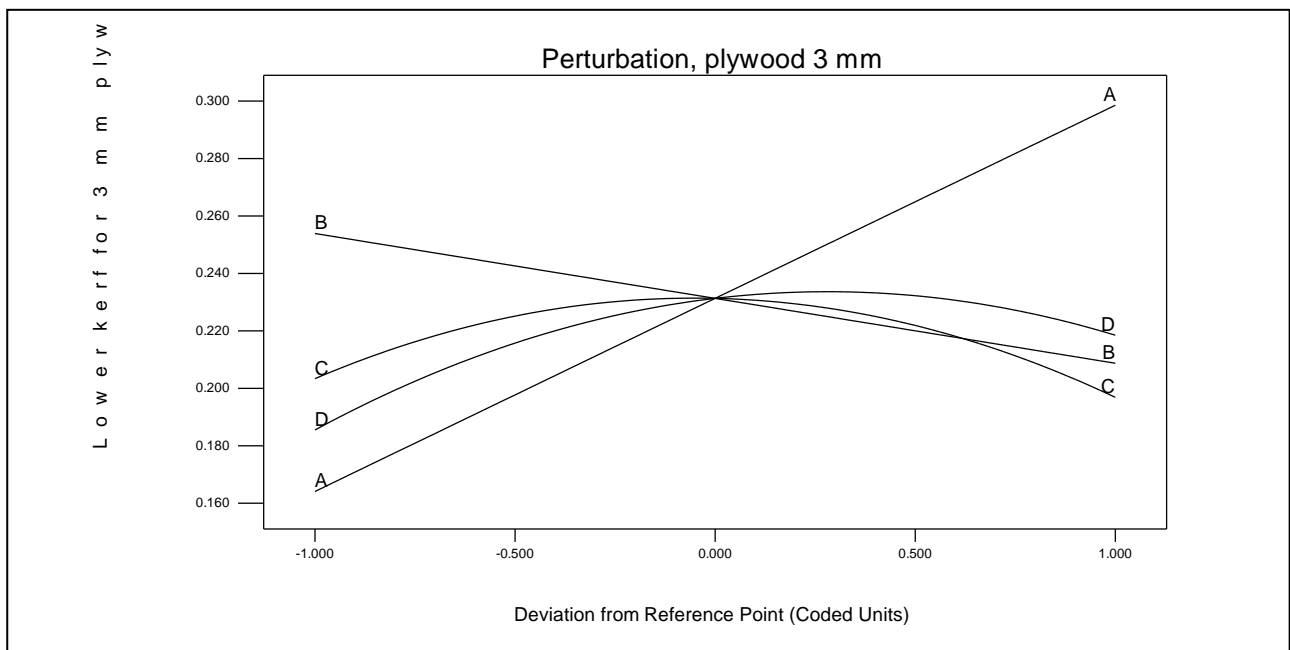

(a)

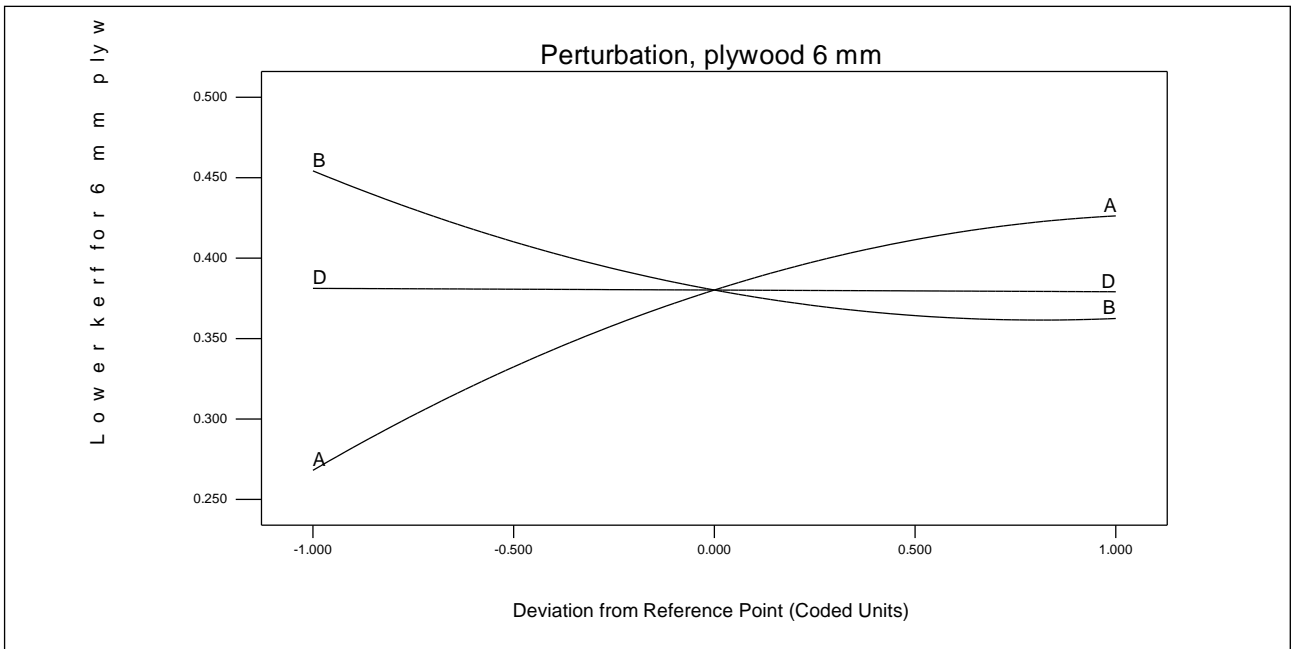

(b)

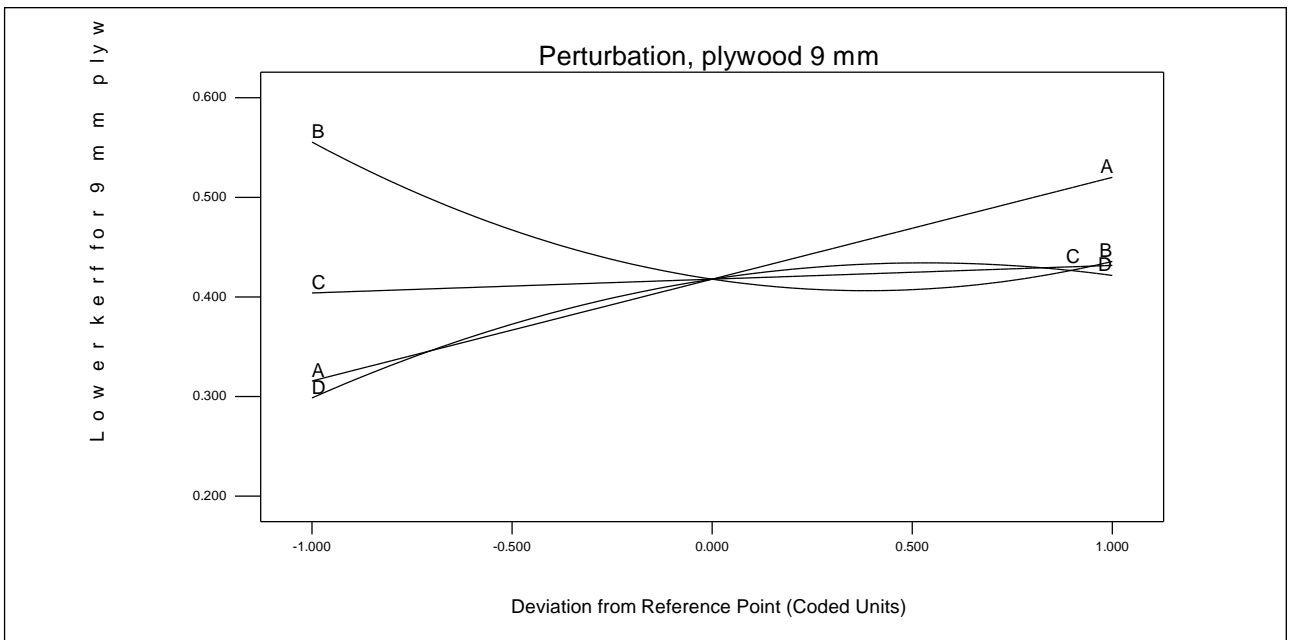

(c)

Fig. 4(a-c): Perturbation plots showing the effect of each factor on the average lower kerf for the (a) 3 mm thick, (b) 6 mm thick and (c) 9 mm thick.

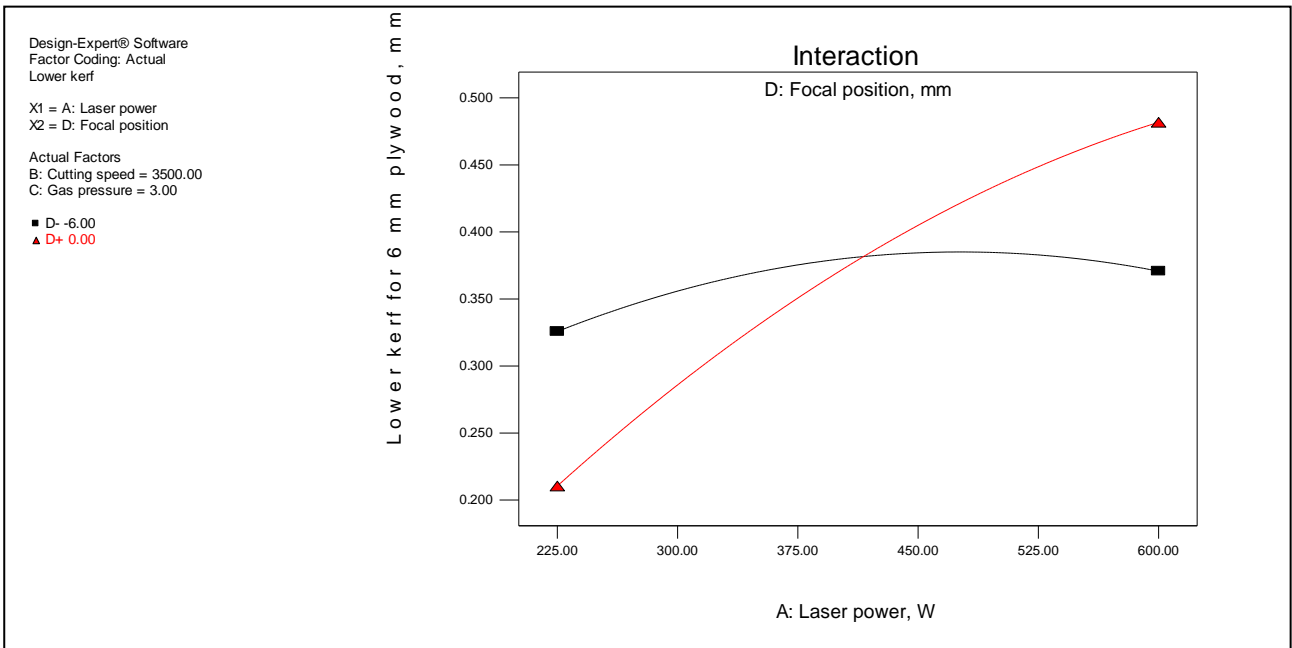

Fig. 5: Interaction graph between laser power and focal point position for the 6 mm thick plywood.

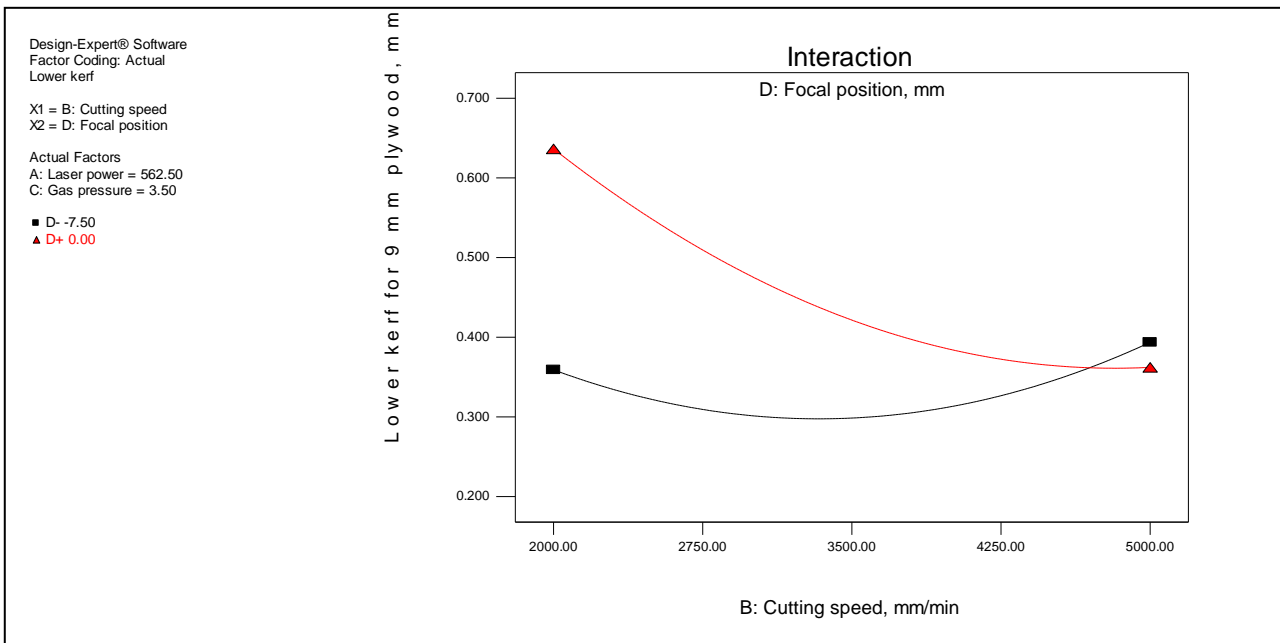
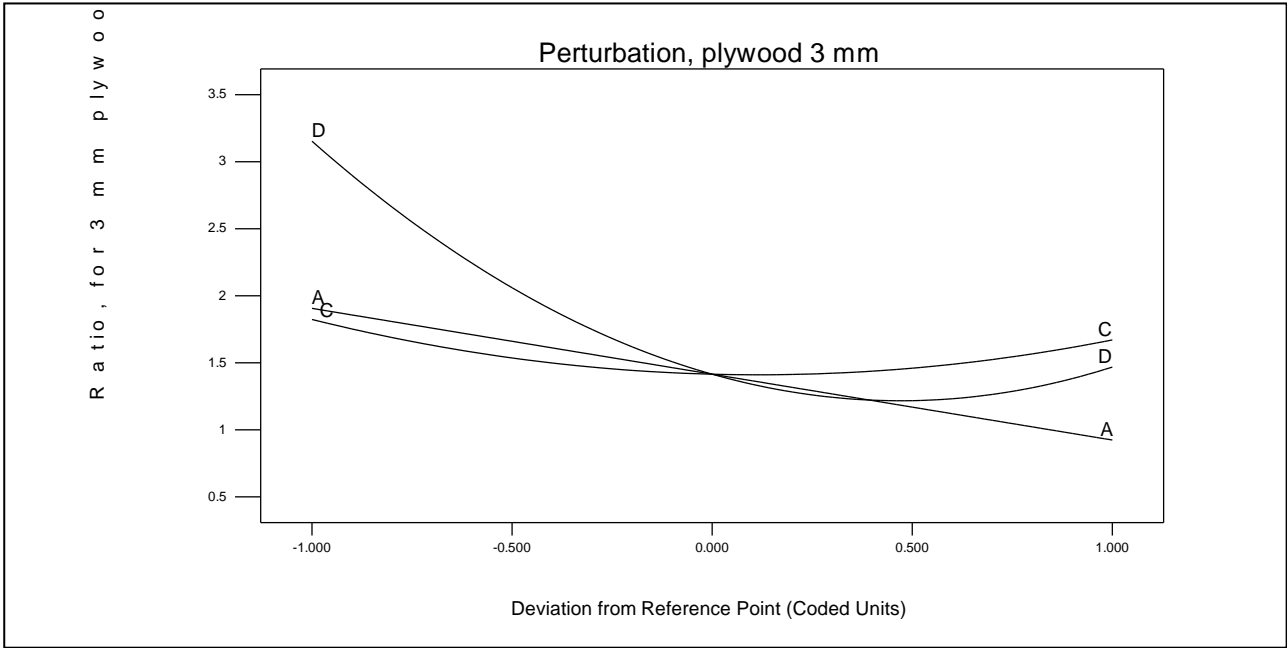

Fig. 6: Interaction graph between cutting speed and focal point position for the 9 mm thick plywood.

### 3.5.3 Ratio between upper kerf to lower kerf

Fig. 7(a-c) perturbation plots show the effect of the considered cutting parameters on the ratio between the upper kerf to the lower kerf for all thicknesses. It is evident that the factor which has the main role on the ratio between the upper kerf to the lower kerf is the focal position, in particular the ratio decreases as the focal position increases. The laser power has the second main effect on the ratio as shown from the same figure, where it could be seen that the ratio decreases as the laser power increases. Indeed, this effect becomes less significant as the thickness increases. Additionally, the ratio increases as the cutting speed increases up to around 3750 mm/min for 6 mm thick and 3500 mm/min for 9 mm thick, and then it starts to decrease as the cutting speed increases. Finally, the air pressure has a slight effect only on the ratio for 3 mm thick. The change of focal position and laser power factors from its lowest value to its highest value while keeping the other factors at their centre values will bring to a percentages change in the ratio as follows (the percentages are for 3 mm, 6 mm and 9 mm thick, respectively): (a) changing focal position would lead up to a decrease of 114.85%, 122.30% and 208.32%; (b) changing the laser power would lead up to a decrease of 106.28%, 26.23% and 58.87%. The percentages of changes in the ratio as a result of changing cutting speed for the 6 mm thick and 9 mm thick consist of a decrease of 12.79% and 0.10%. Moreover, the change in the ratio as a result of changing air pressure for the 3 mm is of 9.10%. Fig. 8(a-c) contour graphs show the effect of the focal point position and the laser power on the ratio for the three thicknesses. This figure is useful for picking out the area in which the desirable ratio between the upper kerf to the lower kerf is present in order to obtain square cut edge, that is to say the area where the ratio is around 1.



(a)

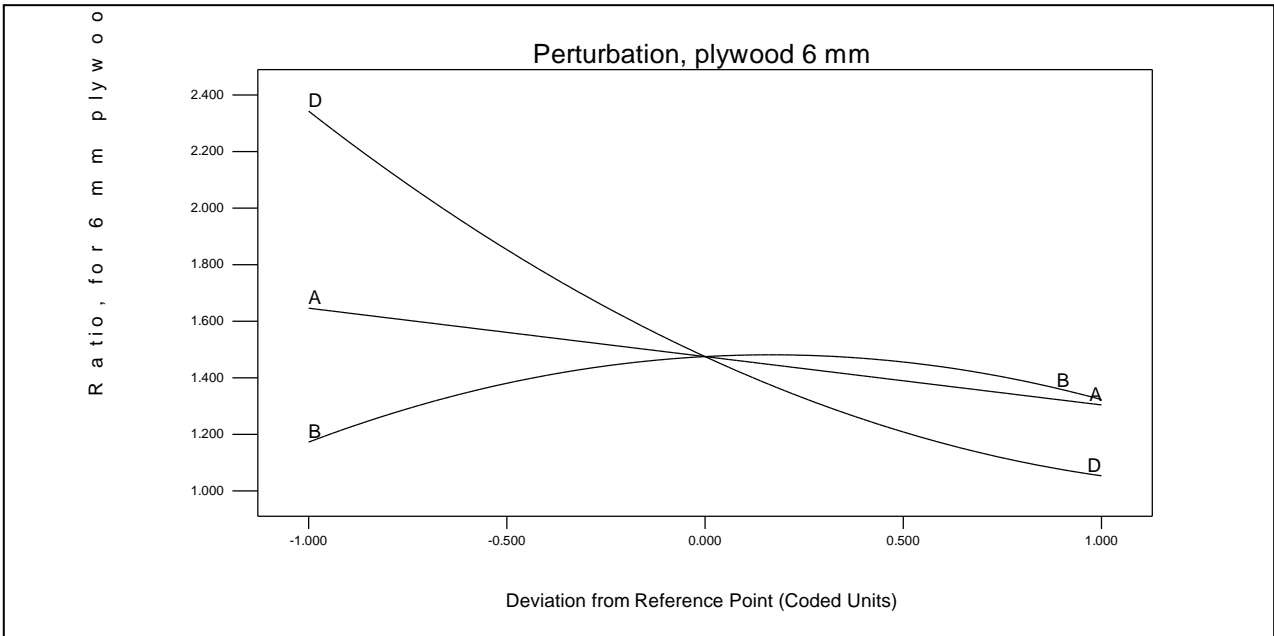

(b)

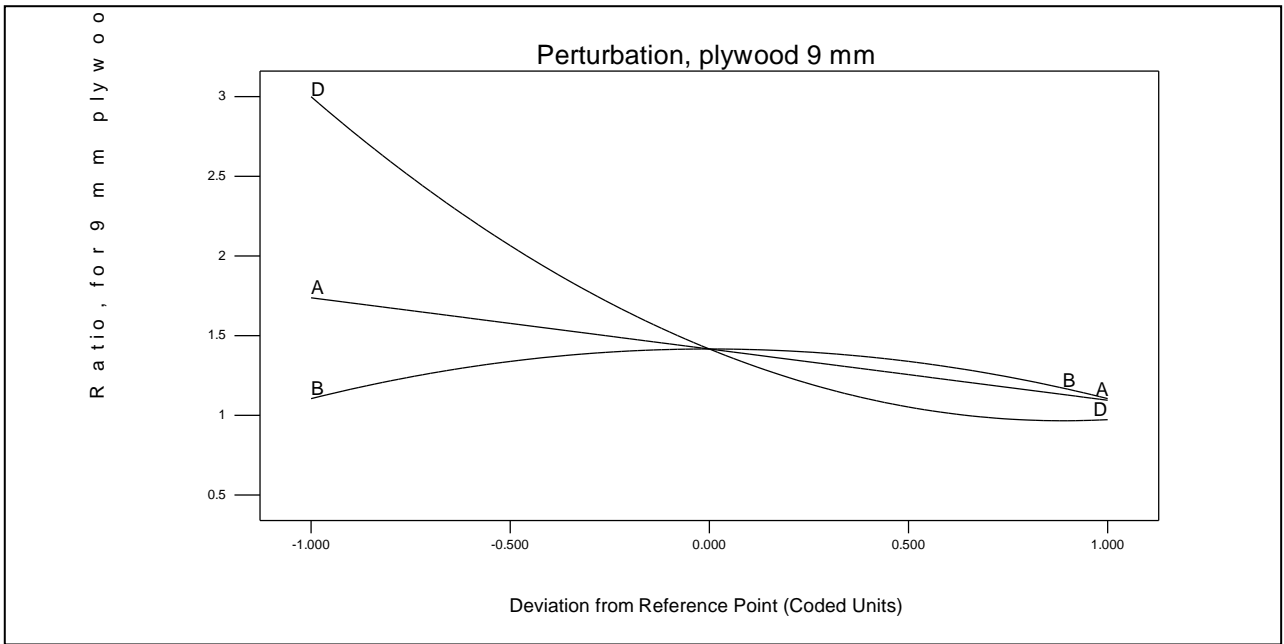

(c)

Fig. 7(a-c): Perturbation plots showing the effect of each factor on the ratio for the (a) 3 mm thick, (b) 6 mm thick and (c) 9 mm thick.

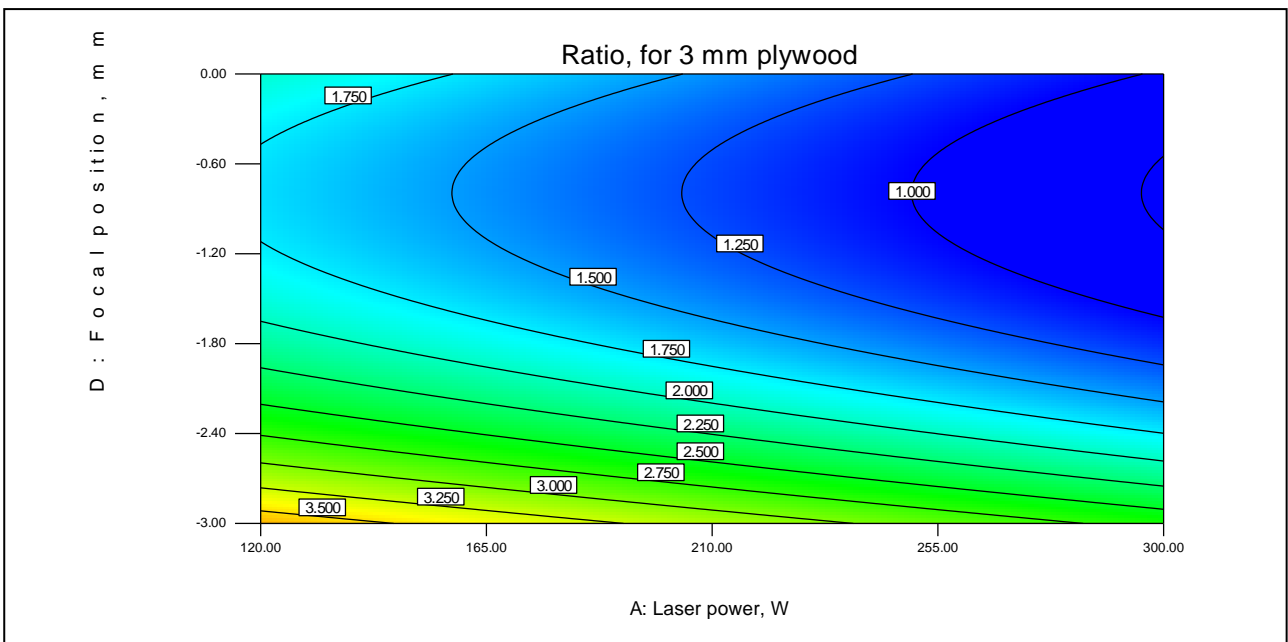

(a)

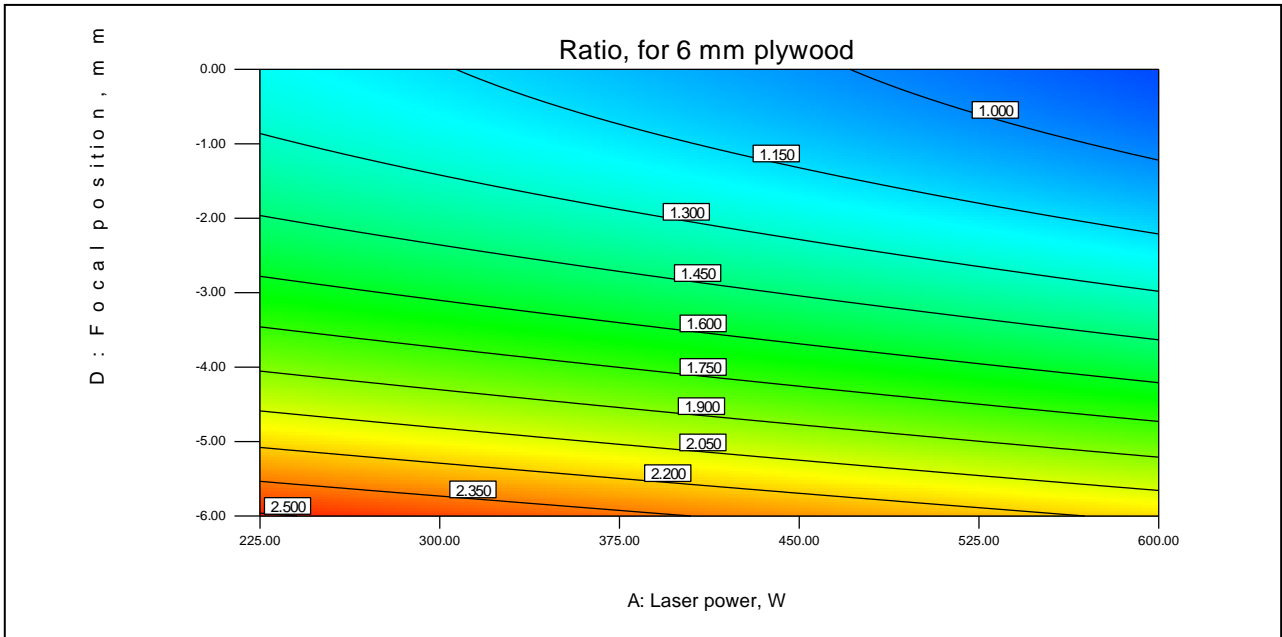

(b)

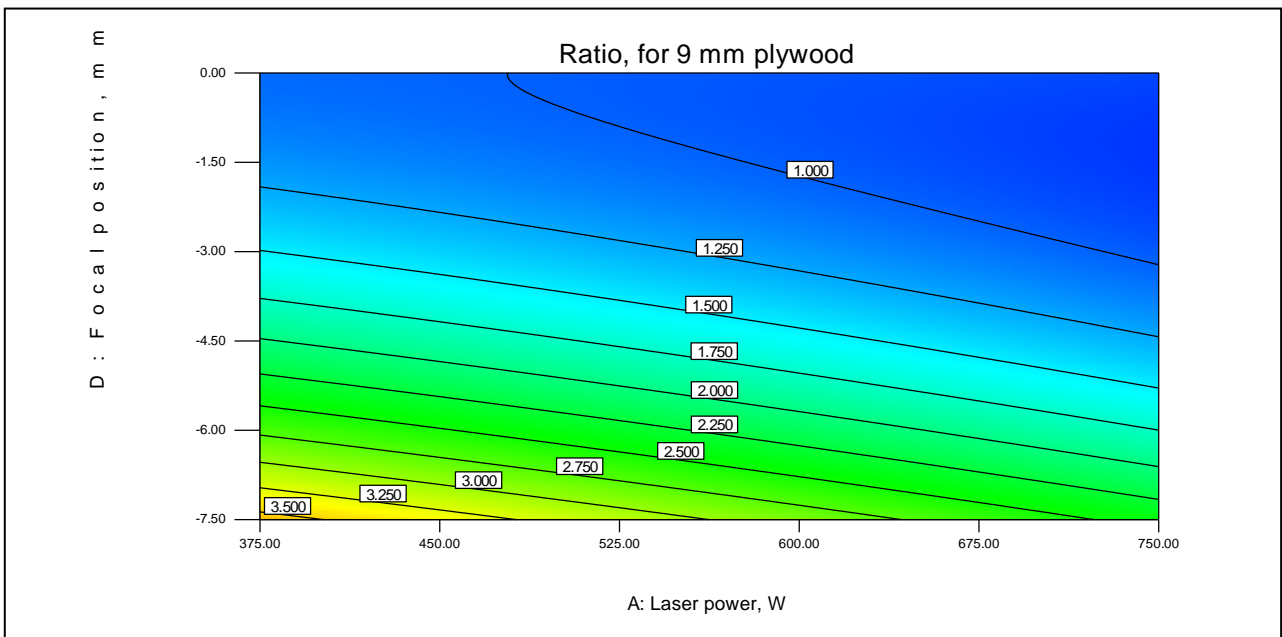

(c)

Fig. 8(a-c): Contours graph showing the effect of focal point position and laser power for the (a) 3 mm thick, (b) 6 mm thick and (c) 9 mm thick.

### 3.5.5 Operating cost

Fig. 9(a-c) perturbation plots show the main effect of the considered cutting parameters on the operating cost. The cutting speed is the main factor that affects the operating cost while the laser power and the compressed air have a slight influence. The focal position has not effect on the operating cost. As regards the cutting speed, it is demonstrated that the operating cost reduces considerably as the cutting speed increases. On the other hand, the operating cost increases as both the laser power and the compressed air pressure increase. The percentages of change in the operating cost as a result of changing cutting speed, laser power and compressed air factors from its lowest value to its highest value while keeping the other factors at their centre values are as follows (the percentages are for 3 mm, 6 mm and 9 mm thick, respectively): (a) changing cutting speed would result in a decrease of 100%, 149.61% and 150.37%; (b) changing the laser power would result in an increase of 8.67%, 18.45% and 17.22%; (c) changing the compressed air would result in an increase of 1.29%, 1.09% and 1.03%.

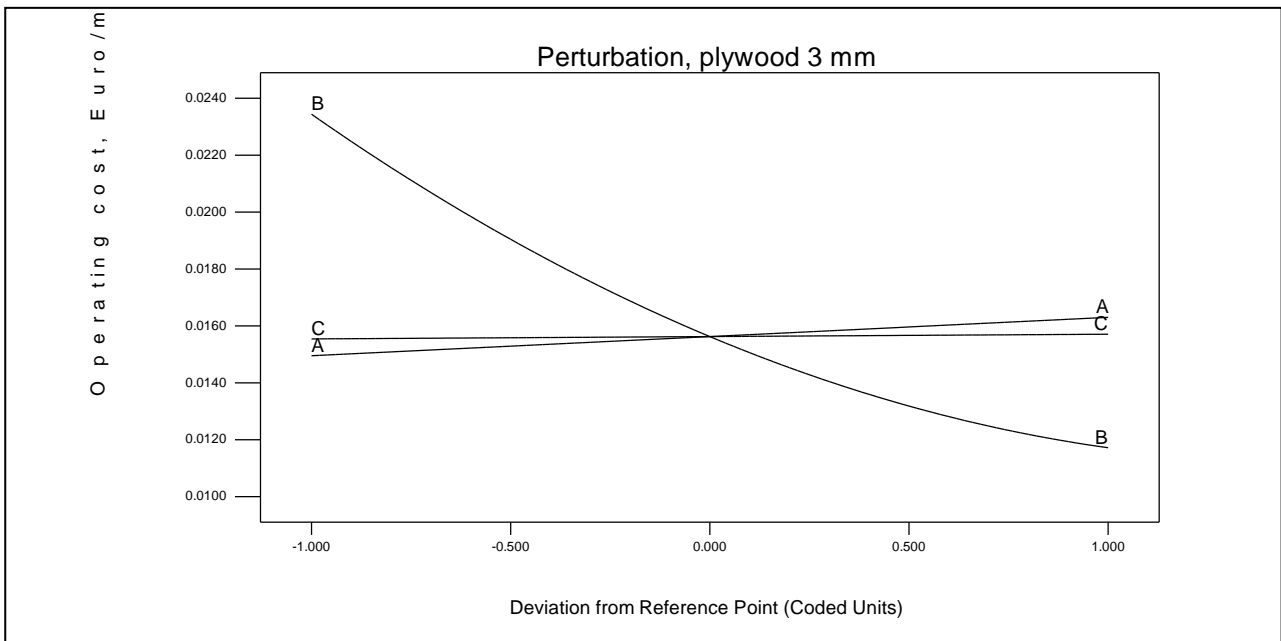

(a)



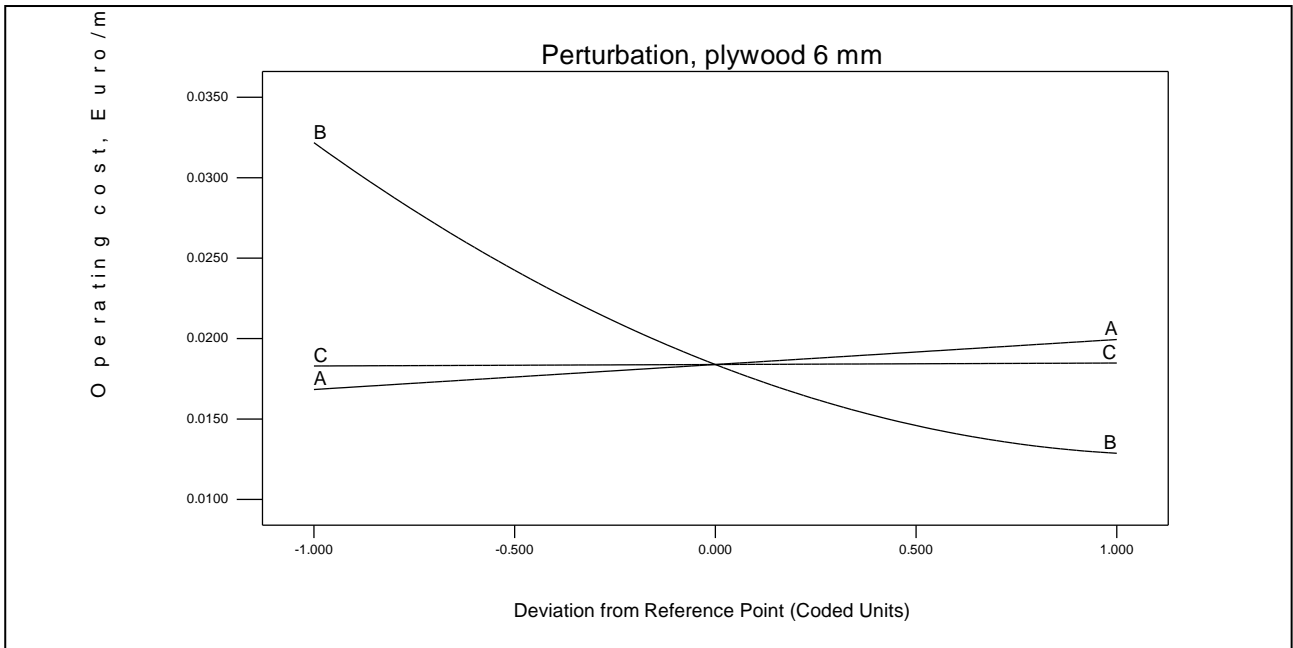

(b)

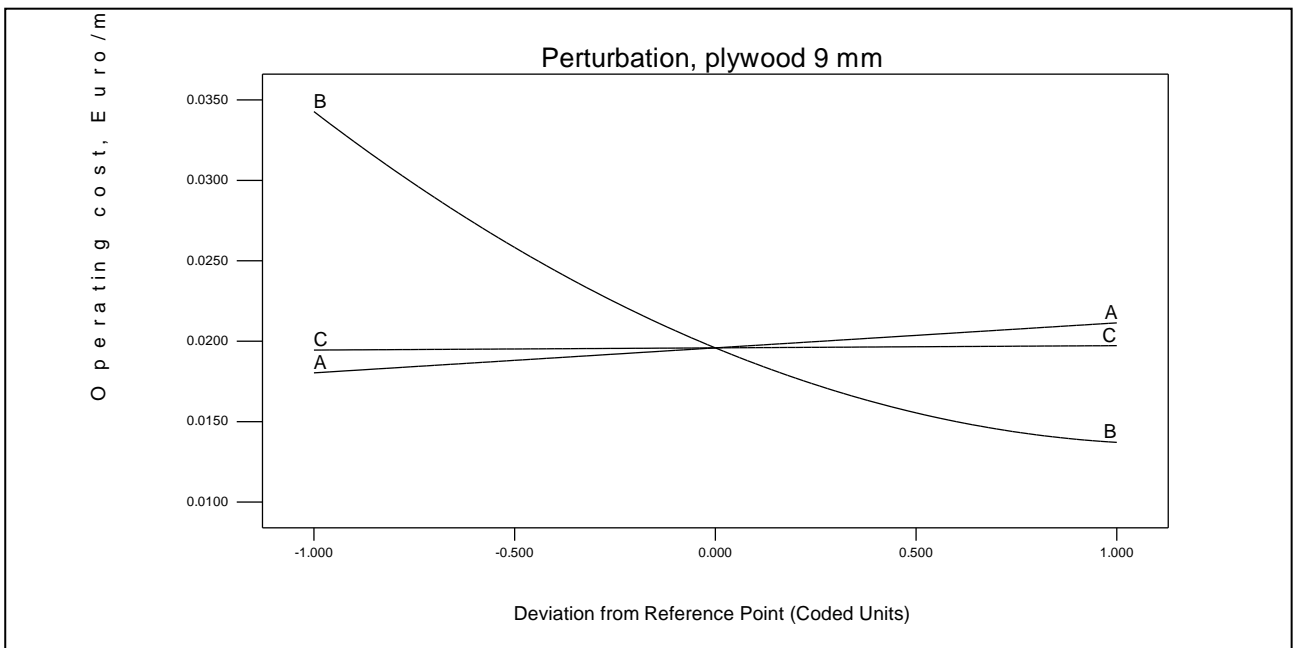

(c)

Fig. 9(a-c): Perturbation plots showing the effect of each factor on the operating cost per meter for the (a) 3 mm thick, (b) 6 mm thick and (c) 9 mm thick.

#### 4. Optimization

Cutting plywood with laser is a multi-factor process and a proper combination of the parameters involved is needed to achieve high quality and optimum process efficiency. Therefore, the optimum values for the CO<sub>2</sub> laser parameters need to be established in order to get the most desirable performance of it. The effect of each factor and its interaction with the other factors on the responses, the output of the process (i.e. responses) and finally the edge quality or the cost of cut section have to be regard with the aim to run any optimization. For this case study, two different optimization criteria have been considered; for each criterion factors and responses have been set with a specific goal as shown in Table 8. As regard the first criterion, the cutting edge quality is considered to be an issue, therefore, no restrictions were made on the four factors. As regard the second criterion, the aim is to find out the optimal cutting conditions which would minimize the operating cost therefore, no restrictions were made on the UK, LW and ratio responses. Solving such multiple response optimization problems using the desirability approach consist of using a technique for combining multiple responses into a dimensionless measure performance called as overall desirability function. The desirability approach is based on the idea that the "quality" of a product or process that has multiple quality characteristics, with one of them outside of some "desired" limits, is completely unacceptable. The method finds operating conditions  $x$  that provide the "most desirable" response values. For each response  $Y_i(x)$ , a desirability function  $d_i(Y_i)$  assigns numbers between 0 and 1 to the possible values of  $Y_i$ , with  $d_i(Y_i) = 0$  representing a completely undesirable value of  $Y_i$  and  $d_i(Y_i) = 1$  representing a completely desirable or ideal response value. The individual desirabilities are then combined using the geometric mean, which gives the overall desirability  $D$  (Eq. 17):

$$D = (d_1(Y_1) \cdot d_2(Y_2) \cdot \dots \cdot d_k(Y_k))^{1/k} \quad (17)$$

with  $k$  denoting the number of responses. Notice that if any response  $Y_i$  is completely undesirable ( $d_i(Y_i) = 0$ ), then the overall desirability is zero. In practice, fitted response values  $\hat{Y}_i$  are used in place of the  $Y_i$ . Depending on whether a particular response  $Y_i$  is to be maximized, minimized, or assigned a target value, different desirability functions  $d_i(Y_i)$  can be used. This optimization technique has flexibility in assigning weights and importance on each factor and responses [27 – 29]. The optimal solutions found for all thicknesses are presented in Tables 9-11. They satisfy the desirable goals for each factor and response and look for either, maximize the cut edge quality (i.e. by setting the ratio around 1) or minimize the cutting cost (i.e. by minimizing both the laser power

and air pressure as well as maximizing the cutting speed) in an attempt to optimize the laser cutting process of plywood.

Table 8: Criteria for numerical optimization.

Factor or response	First criterion (Cutting edge quality)		Second criterion (Cost)	
	Goal	Importance	Goal	Importance
Laser power	Is in range	3	Minimize	5
Cutting speed	Is in range	3	Maximize	5
Air pressure	Is in range	3	Minimize	3
Focal position	Is in range	3	Is in range	3
Upper Kerf	Is in range	3	Is in range	3
Lower Kerf	Is in range	3	Is in range	3
Ratio	Target to 1	5	Is in range	3
Operating cost	Is in range	3	Minimize	5

#### 4.1 Optimization of 3 mm plywood

Table 9: Optimal solution as obtained by Design-Expert for plywood 3 mm.

	No.	A, W	B, mm/min	C, bar	D, mm	Upper kerf, mm	Lower kerf, mm	Ratio	Cost, €/m	Desirability
1 <sup>st</sup> criterion Quality	1	278.39	4891.45	1.46	-0.21	0.306	0.247	1.000	0.0122	1
	2	263.84	3389.45	1.51	-0.92	0.312	0.274	1.000	0.0179	1
	3	260.45	3309.71	2.33	-1.03	0.302	0.275	1.000	0.0184	1
	4	256.60	4219.26	2.26	-0.74	0.283	0.256	1.000	0.0140	1
	5	267.33	2582.66	2.13	-0.36	0.316	0.290	1.000	0.0234	1
2 <sup>nd</sup> criterion Cost	1	120.00	4999.99	1.14	-0.99	0.270	0.123	1.962	0.0112	0.9881
	2	120.01	5000.00	1.14	-1.16	0.277	0.123	2.025	0.0112	0.9880
	3	120.00	4999.99	1.14	-1.20	0.278	0.123	2.043	0.0112	0.9878
	4	122.77	5000.00	1.10	-1.05	0.275	0.123	1.992	0.0113	0.9872
	5	120.37	4999.96	1.14	-0.87	0.268	0.123	1.926	0.0112	0.9871

The optimal combinations of process factors and the correspondence responses values for both quality and cost criteria for 3 mm plywood are listed in Table 9. If the aim is to achieve predicted ratio as close as possible to one a laser power between 267.33 W and 383.69 W, cutting speed ranged between 2582.66 mm/min and 4891.45 mm/min, a air pressure between 1.46 and 2.26 and nearly focused beam ranged between -1.03 and -0.87 mm have to be set. These optimal results agree well enough with the conclusion presented in the reference [15]. On the other hand, if the main aim is reducing the cost, it is verified that, the minimum laser power, the maximum cutting speed, air pressure of 1 about bar and focal point position ranged from -1.20 to -0.87 mm have to be used. It is very interesting to compare the two criteria as follows: with reference to the cut edge quality, the predicted ratio is on average 98.96% less than the one of the cost criterion and

theoretically equals to 1, which means the cut edge is square. However, the cutting operating cost in the first criterion is 53.39 % higher than the operating cost of the second criterion.

Table 10: Optimal solution as obtained by Design-Expert for plywood 6 mm.

	No.	A, W	B, mm/min	C, bar	D, mm	Upper kerf, mm	Lower kerf, mm	Ratio	Cost, €/m	Desirability
1 <sup>st</sup> criterion Quality	1	336.39	4908.86	3.63	-0.10	0.295	0.301	1.000	0.0127	1
	2	305.84	2411.96	2.56	-0.31	0.342	0.343	1.000	0.0263	1
	3	432.92	4729.66	2.05	-0.68	0.343	0.374	1.000	0.0133	1
	4	396.51	4697.68	3.07	-0.23	0.320	0.349	1.000	0.0132	1
	5	578.08	2522.37	2.36	-2.07	0.499	0.481	1.000	0.0282	1
2 <sup>nd</sup> criterion Cost	1	225.00	5000.00	2.00	-1.42	0.313	0.220	1.217	0.0120	0.9985
	2	225.00	5000.00	2.00	-5.18	0.663	0.292	2.079	0.0120	0.9985
	3	225.00	5000.00	2.00	-1.78	0.333	0.227	1.269	0.0120	0.9985
	4	225.00	4999.99	2.00	-5.98	0.778	0.308	2.354	0.0120	0.9985
	5	225.00	5000.00	2.00	-5.24	0.672	0.294	2.101	0.0120	0.9985

#### 4.2 Optimization of 6 mm plywood

The optimal combinations of process factors and the correspondence responses values for both quality and cost criteria for 6 mm plywood are shown in Table 10. It is obvious that to get predicted ratio of one a laser power ranged between 305.84 and 578.08 W, cutting speed between 2522.37 and 4908.86 mm/min with air pressure ranged between 2.05 and 3.63 bar and focal point position ranged from -2.07 to -0.10 mm have to be used. Accordingly, the focal position is almost on the surface and these optimal results are in good agreement with the conclusion obtained in the reference [15]. Conversely, if reducing the operation cost is more important, it is necessary to apply the minimum laser power with maximum cutting speed, air pressure between of 2 bar and focal point position ranged from -5.24 to -1.42 mm. As mentioned above, it is useful to compare the two criteria as follows: with respect to the quality of the cut section, the predicted ratio is on average 80.40 % less than the ratio obtained in the cost criterion and in theory equals to 1, which means the cut edge is square. However, the cutting operating cost in the first criterion is 56.17 % higher than the operating cost of the second criterion.

Table 11: Optimal solution as obtained by Design-Expert for plywood 9 mm.

	No.	A, W	B, mm/min	C, bar	D, mm	Upper kerf, mm	Lower kerf, mm	Ratio	Cost, €/m	Desirability
1 <sup>st</sup> criterion Quality	1	411.25	2761.77	4.72	-0.91	0.396	0.421	1.000	0.0243	1
	2	740.26	2821.12	3.60	-3.50	0.593	0.566	1.000	0.0270	1
	3	745.86	3503.01	2.25	-3.18	0.552	0.518	1.000	0.0210	1
	4	584.92	2052.57	3.13	-3.40	0.582	0.570	1.000	0.0339	1
	5	393.35	2969.26	3.86	-0.29	0.364	0.370	1.000	0.0222	1
2 <sup>nd</sup> criterion Cost	1	375.00	5000.00	2.00	-1.95	0.367	0.286	0.945	0.0128	0.9991
	2	375.00	5000.00	2.00	-6.75	0.742	0.317	2.809	0.0128	0.9991
	3	375.00	5000.00	2.00	-1.83	0.362	0.283	0.924	0.0128	0.9991
	4	375.00	4999.99	2.00	-4.16	0.508	0.323	1.571	0.0128	0.9991
	5	375.00	5000.00	2.00	-6.55	0.722	0.319	2.699	0.0128	0.9991

### 4.3 Optimization of 9 mm plywood

The optimal combinations of process factors and the correspondence responses values for both quality and cost criteria for 9 mm plywood are presented in Table 11. It is evident that to obtain predicted ratio close to one a laser power ranged between 393.35 and 745.86 W, cutting speed between 2052.57 and 3503.01 mm/min with air pressure ranged between 2.25 and 4.72 bar and focal point position spanning from -3.50 to -0.29 mm have to be used. These optimal results agree well enough with the results obtained in the reference [15], given that the focal position is almost on the surface. Instead, if minimizing the cost is fundamental, it is confirmed that, the minimum laser power with maximum cutting speed, air pressure of 2 bar and focal point position ranged from -6.75 to -1.83 mm should be used. In comparison between the two criteria and concerning the quality of the cut section, the predicted ratio got in the quality criterion is on average 78.97 % less than the ratio obtained in second criterion. However, the cutting operating cost in the first criterion is 100.63 % higher than the operating cost of the second criterion.

### 5. Conclusion

The following conclusion can be drawn from this investigation within the factors limits and only applicable for experiment setup considered in this study and for the specified material:

- 1- The effects of all investigated factors have been set up and every factor has a potential effect on the responses with different level.
- 2- The focal point position has the major role in influencing the average upper kerf width and the latter decreases as the focal position increases. Moreover, the upper kerf decreases as the cutting speed and air pressure increase, and it increases as the laser power increases.

- 3- The laser power and cutting speed have the main effect on the average lower kerf width and the latter decreases as the cutting speed increases while it increases as the laser power increases. Moreover, the lower kerf increases as the focal position increases.
- 4- The focal point position and the laser power have the principal role in affecting the ratio. It decreases as the focal point position and laser power increase, however, the laser power becomes less significant as the thick of the plywood specimen decreases. As regards the cutting speed, the ratio has a particular trend: it increases as the cutting speed increases up to around 3750 mm/min, and then it starts to decrease.
- 5- Economical cut sections and high quality could be carried out following the tabulated optimal cost setting shown above, but with increase in the predicted ratio of 98.96 %, 80.40 % and 78.97 % for 3, 6 and 9 mm plywood respectively.
- 6- A ratio as close as possible to 1 could be obtained following the tabulated optimal quality setting shown above, but with increase in the processing operating cost of 53.39 %, 56.17 % and 100.63 % for 3, 6 and 9 mm plywood respectively.

## References

- [1] J.V. Den Bulcke, J.V. Acker, J. De Smet. An experimental set-up for real-time continuous moisture measurements of plywood exposed to outdoor climate. *Building and Environment* 2009; 44(12): 2368-2377.
- [2] U. Heisel , H. Krondorfer. Surface method for vibration analysis in peripheral milling of solid wood. *Proceedings of the 12th international wood machining seminar, Kyoto, Japan, 1995.*
- [3] R. Kantay R, T. Akbulut, S. Korkut. Effect of peeling temperature on surface roughness of rotary cut veneer. *Review of Faculty of Forestry, Istanbul University* 2004; 53:1–11.
- [4] H.A. Eltawahni, A.G. Olabi. High power laser cutting of different materials - a literature review, *proceedings of IMC 2008 25th Inter. Conf., 3rd - 5th September 2008 held in DIT Dublin-Ireland.*
- [5] A.G. Olabi, H. A. Eltawahni. Effect of CO<sub>2</sub> laser cutting process parameters on the kerf width of AISI316, *proceedings of AMPT 2008 Inter. Conf., November 2-5, 2008 held in Manama, Kingdom of Bahrain.*
- [6] H.A. Eltawahni, A.G. Olabi, K.Y. Benyounis. Effect of process parameters and optimization of CO<sub>2</sub> laser cutting of ultra high-performance polyethylene. *Materials and Design* 2010; 31, 8: 4029-4038.

- [7] H.A. Eltawahni, A.G. Olabi, K.Y. Benyounis. Assessment and Optimization of CO<sub>2</sub> Laser Cutting Process of PMMA. International conference on advances in materials and processing technologies AIP Conference Proceedings 2011; 1315: 1553-1558.
- [8] J. Powell, G. Ellis, I.A. Menzies, P.F. Scheyvaerts. CO<sub>2</sub> laser cutting of non-metallic materials in 4th International Conference Lasers in Manufacturing 1987.
- [9] D.A. Belforte. Non-metal cutting. Industrial laser review 1998; 13(9): 11-13.
- [10] M.C. Pires. Plywood inlays through CO<sub>2</sub> laser cutting. CO<sub>2</sub> Laser and Applications. SPIE Proceedings 1989; 1042: 97-102.
- [11] G. Wieloch, P. Pohl. Use of laser in the furniture industry. Proceedings of SPIE 1995; 2202: 604-607.
- [12] P.A.A. Khan, et al. High speed precision laser cutting of hardwoods. Laser materials processing III. Proceedings of the third symposium on laser material processing, sponsored by the TMS, 1989; pp. 233-248.
- [13] K. Mukherjee, et al. Gas flow parameters in laser cutting of wood-nozzle design. Forest products journal 1990; 40(10): 39-42.
- [14] R.J. Rabiej, S.N. Ramrattan, W.J. Droll. Glue shear strength of laser-cut wood. Forest products journal 1993; 43(2): 45-55.
- [15] V.G. Barnekov, H.A. Huber, C.W. McMillin. Laser machining wood composites. Forest Products Journal 1989; 39(10): 76-78.
- [16] K. C. P. Lum, S. L. Hg and I. Black. CO<sub>2</sub> laser cutting of MDF, 1- Determination of process parameter settings. Journal of Optics and Laser Technology 2000; 32: 67-76.
- [17] H.A. Eltawahni, A.G. Olabi, K.Y. Benyounis. Investigating the CO<sub>2</sub> laser cutting parameters of MDF wood composite material. Optics and Laser Technology 2011; 43(3): 648-659.
- [18] P.A.A. Khan, M. Cherif, S. Kudapa, V. Barnekov, K. Mukherjee. High speed, high energy automated machining of hardwoods by using a Carbon Dioxide Laser: ALPS. Laser Institute of America 1722; pp. 238-252.
- [19] V.G. Barnekov, C.W. McMillin, H.A. Huber. Factors Influencing Laser Cutting Of Wood. Forest Products Journal 1986; 36(1): 55-58.
- [20] L. Grad, J. Mozina. Optodynamic studies of Er: YAG laser interaction with wood. Applied Surface Science 1998; 127(129): 973-976.
- [21] N. Hattori. Laser Processing Of Wood. Mokuzai Gakkaishi 1995; 41(8): 703-709.
- [22] E. Kannatey-Asibn. Principles of laser materials processing. Hoboken, New Jersey: John Wiley & Sons, Inc 2009; ISBN 978-0470177983.
- [23] J.C.H. Castaneda, H. K. Sezer, L. Li. Statistical analysis of ytterbium-doped fibre laser cutting of dry pine wood. Journal of Engineering Manufacture 2009; 223(part B): 775-789.

- [24] K.Y. Benyounis, A.G. Olabi, M.S.J. Hashmi. Multi-response optimization of CO<sub>2</sub> laser-welding process of austenitic stainless steel. *Optics & Laser Technology* 2008; 40(1): 76-87.
- [25] K.Y. Benyounis, A.G. Olabi, M.S.J. Hashmi. Effect of laser welding parameters on the heat input and weld-bead profile. *Journal of Materials Processing Technology* 2005; 164-165(15): 978-85.
- [26] Tsai MJ, Li CH. The use of grey relational analysis to determine laser cutting parameters for QFN packages with multiple performance characteristics. *Optics & Laser Technology* 2009; 41(8): 914-21.
- [27] K.Y. Benyounis, A.G. Olabi. Optimization of different welding process using statistical and numerical approaches-A reference guide, *Journal of Advances in Engineering Software* 2008; 39: 483-496.
- [28] A. Ruggiero, L. Tricarico, A.G. Olabi, K. Y. Benyounis, Weld-bead profile and costs optimization of the CO<sub>2</sub> dissimilar laser welding process of low carbon steel and austenitic steel AISI316, *Optics & Laser Technology*, Volume 43, Issue 1, February 2011, Pages 82-90.
- [29] A. G. Olabi, G. Casalion, K. Y. Benyounis, and M. S. J. Hashmi, Minimization of the residual stress in the heat affected zone by means of numerical methods, *J. of Materials & Design*, Vol. 28, No. 8, 2007, pp. 2295-2302.
- [30] A. G. Olabi, K. Y. Benyounis, M. S. J. Hashmi. Application of Response Surface Methodology in Describing the Residual Stress Distribution in CO<sub>2</sub> Laser Welding of AISI304. *Strain* 2007; 43 (1): 37-46.
- [30] H. A. Eltawahni, M. Hagino, K. Y. Benyounis, T. Inoue, A.G. Olabi Effect of CO<sub>2</sub> laser cutting process parameters on edge quality and operating cost of AISI316L, *Optics & Laser Technology*, Vol. 44, Issue 4, June 2012, pp. 1068-1082.
- [32] K.C.P. Lum, S.L. Hg, I. Black. CO<sub>2</sub> laser cutting of MDF, Estimation of power distribution. *Journal of Optics and Laser Technology* 2000; 32: 77-87.
- [33] J. Powell, CO<sub>2</sub> Laser Cutting, 2<sup>nd</sup> Edition, Springer-Verlag Berlin Heidelberg, New York, (1998).